



Desigo™ PX

Web interface BACnet/IP

PXG3.W100

Local or remote operation of one or multiple PX automation station(s) via
Desigo Touch Panels (TP) and standard web browser

- Connection via Ethernet
- Central user interface for simultaneous access from various operator units
- Central management of plant graphics and other user views
- Offline engineering using Xworks Plus
- Upload/download of configuration data via LAN, or Internet
- LED indication for Ethernet link and activity
- 2-port Ethernet switch for low-cost cabling (10/100baseT)
- Plug-in screw terminal block for supply
- Operating voltage AC 24 V or DC 24 V
- Mounting on DIN rail

Topology

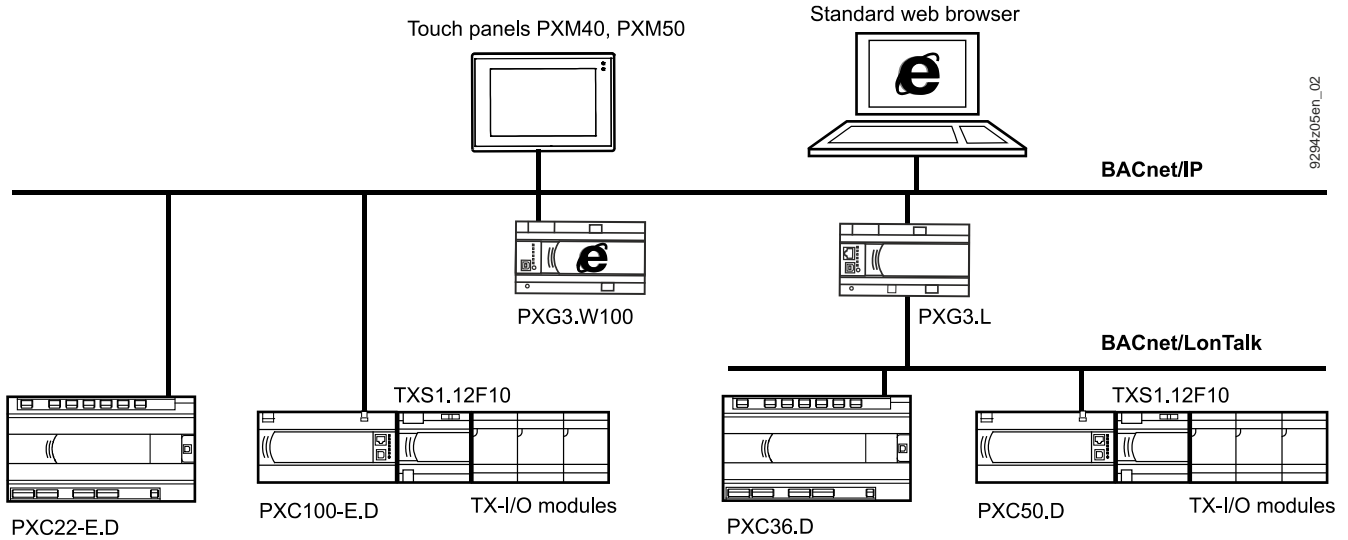

The PXG3.W100 web interface serves as the central access point to operate the automation level. A central access point also allows for concurrent operation of different operator units while supporting connection of the Desigo touch panels PXM40 / PXM50 as well as providing access using devices featuring a standard web browser. The following functions are available to operate and monitor a plant:

- Login and logout.
- Simple plant overview is possible without user login.
- Limit view to plant level.
- Graphical plant operation.
- Alarm list to monitor alarms.
- List of favorites for text-based operation of freely selectable data points.
- Adjust scheduler via graphical function.
- Visualize trend objects (offline trend).
- Local settings (e.g. languages).
- Optimized interface for Desigo touch panels PXM40 / PXM50 for local plant operation and monitoring.

Desigo Xworks Plus is used to engineer the PXG3.W100 web interface.

Ordering

When ordering, please specify the quantity, type, and **product name**.

Example:

Number	Type (ASN)	Product number (SSN)	Product designation
1	PXG3.W100	S55842-Z115	BACnet/IP web interface

Document type	Document no.
Data sheet Touch Panel PXM40,	CM1N9292
Data sheet Touch Panel PXM50	CM1N9293
Operating instructions Desigo Touch and Web	CM111028
Installation and commissioning instructions Desigo Touch and Web	CM111029
Engineering: Online help for Desigo Xworks Plus	CM111006en.chm

Functions

Communication

The web interface has a 2-port Ethernet switch for low-cost cabling via line topology.
A USB port is available for service and commissioning.

Web server

The device has a web server processing data in HTML5 web pages from multiple Desigo PX and other BACnet IP-based devices. Date and time can be viewed via web server.

Web browser compatibility

See Installation and commissioning instructions Desigo Touch and Web, CM111029.

Service button

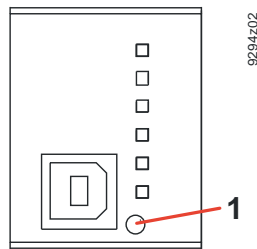

Button	Press	Description
1	Short	Physical identification on the network (Ethernet)

LEDs

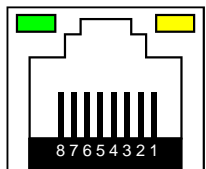
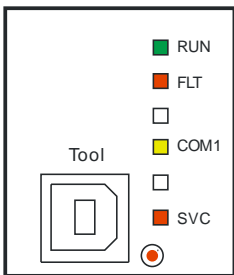

LED	Color	Activity	Function
RUN	Green	<ul style="list-style-type: none"> Steady ON Steady OFF Flashing 	<ul style="list-style-type: none"> Device ready for operation. Min. one internal supply in inadmissible range. Device starts or program stops.
FLT	Red	<ul style="list-style-type: none"> Steady OFF Steady ON Flashing 	<ul style="list-style-type: none"> OK HW or program error. Wrong or corrupt firmware.
COM1	Yellow	<ul style="list-style-type: none"> Flashing 	<ul style="list-style-type: none"> Sends HTTP packets.
SVC	Red	<ul style="list-style-type: none"> Steady OFF Flashing 	<ul style="list-style-type: none"> Configured. Unconfigured.
Ethernet 1 / 2	Green	<ul style="list-style-type: none"> Steady OFF Flashing 	<ul style="list-style-type: none"> No connection. Sends 10 or 100 Mbps Ethernet IP packets.
	Yellow	<ul style="list-style-type: none"> Steady ON 	<ul style="list-style-type: none"> Link 100 Mbps

Mechanical design

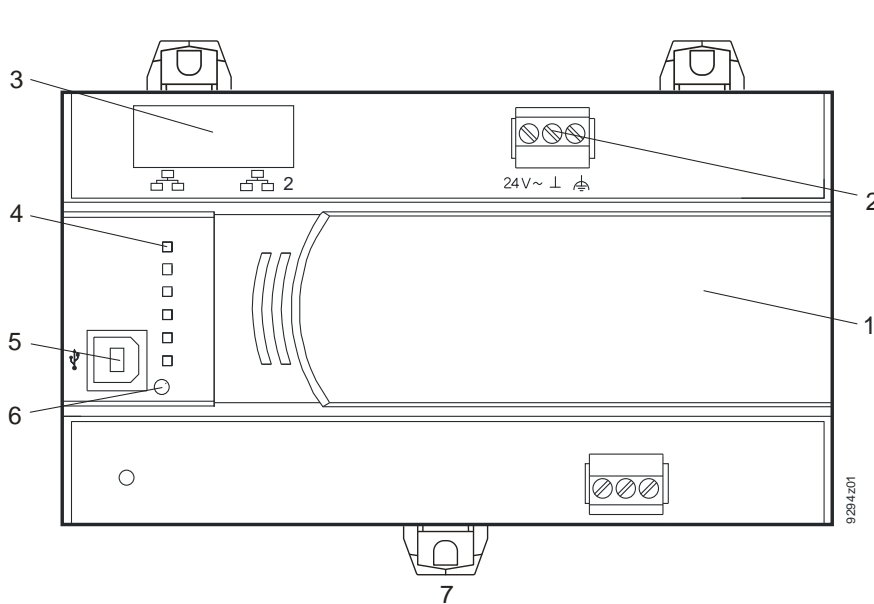

- 1 Plastic housing
- 2 Plug-in terminal block (operating voltage)
- 3 2-port Ethernet switch (with 2 LEDs per port for display purposes)
- 4 LED display for device and system status
- 5 Tool interface (USB)
- 6 Service button for identification on network
- 7 Slider for mounting on DIN rail

Notes

Engineering	Cable length, topology, etc.: See installation manual Desigo TRA, CM111043.
Mounting	The web interface is designed for mounting on a standard rail as well as on walls. The supply is connected to plug-in screw terminal blocks.
Installation	Note the guidelines from the mounting and installation manual (CA110396). See installation manual Desigo TRA, CM111043.
Commissioning	Xworks Plus is used for configuration and engineering. The online help for Xworks Plus (CM111006en.chm) as well as the installation and commissioning instructions Desigo Touch and Web CM11029en contain all information required to configure and commission the device. Each device has a unique identification number to ensure efficient commissioning. It is also printed on the removable barcode label. To prevent equipment damage and/or personal injuries always adhere to local safety regulations and the required safety standards.
Maintenance	The PXG3.W100 is maintenance-free.
Firmware upgrade	The firmware can be upgraded via Ethernet and USB interface using the firmware download tool Desigo SSA-DNT.
Repair	The web interface cannot be repaired. The device must be replaced as a whole.
Disposal	The devices are considered electronics devices for disposal in terms of European Directive 2002/96/EC (WEEE) and may not be disposed of as domestic waste. Dispose of the devices via the proper channels. Adhere to all local and currently applicable laws and regulations.



Technical data

Operating voltage (24V \approx , \perp , ⏏)	Safety extra-low voltage SELV or protection by extra-low voltage PELV as per HD384	AC 24 V \pm 20 % 48...63 Hz
	Half-wave load ⏏ = Technical ground	Symmetric DC 24 V \pm 20 %
Power consumption	At AC 24 V	Max. 9 VA
	At DC 24 V	Max. 4 W
	Internal fusing	With PTC
Hardware information	Processor	Atmel ARM9
	Memory	256 MB flash, 64 MB SDRAM
Response to power / communication failure	Energy reserve (Supercap) to support real-time clock (3 days). Data available only if stored to flash memory.	
Ethernet interfaces	Plug	2 x RJ45, screened
	Interface type	100BaseTX, IEEE 802.3 compatible
	Bit rate	10/100 Mbps, autosensing
	Protocol	BACnet over UDP/IP, and HTTP or HTTPs over TCP/IP
USB interface	Plug	Type B (USB device)
	Data rate (USB 1.0 full speed)	12 Mbps
	Galvanic isolation of \perp	No
	Protective switch against surges and over current	Yes
Connection terminals, plug-in	Type	Pluggable screw terminals
	Cu wire or Cu strand with wire end sleeve	1 x 0.6 mm dia. to 2.5mm ²
	Cu strand without wire end sleeve	or 2 x 0.6 mm dia to 1.0 mm ² 1 x 0.6 mm dia. to 2.5 mm ² or 2 x 0.6 mm dia. to 1.5 mm ²
	Screwdriver	Slot screws Screwdriver, size 1 <i>with shaft dia. \leq 4.5 mm</i>
	Max. tightening torque	0.6 Nm
Assignment as per EN 60730	Operation of automatic controller	Type 1
	Degree of pollution	
	Design type	2
Housing protection class	Protection class as per EN 60529	Protection class III
	Front parts in the DIN section	IP30
	Terminal part	IP20
Environmental conditions	Operation	As per IEC 60721-3-3
	Climatic conditions	Class 3K5
	Temperature	-5 ... 50 °C
	Humidity	5 ... 95 % r.h.
	Mechanical conditions	Class 3M2
	Transport	As per IEC 60721-3-2
	Climatic conditions	Class 2K3
	Temperature	-25...70 °C
Humidity	5 ... 95 % r.h.	
Mechanical conditions	Class 2M2	

Standards, directives and approvals

Product safety	Automatic electrical controls devices for household and similar use	EN 60730-1
Electromagnetic compatibility	Immunity (industry & residential)	EN 60730-1
	Emissions (residential)	EN 60730-1
CE conformity	Electromagnetic compatibility	2004/108/EC
	C-tick conformity (EMC)	AS/NZS 61000-6-3
UL approbation		UL916

Environmental compatibility

The product environmental declaration CM1E9294en contains data on environmentally compatible product design and assessments (RoHS compliance, materials composition, packaging, environmental benefit, disposal)	ISO 14001 (Environment) ISO 9001 (Quality)
------------------------------------------------------------------------------------------------------------------------------------------------------------------------------------------------------------------	-----------------------------------------------

Color

Housing	RAL 7035 (light-gray)
---------	-----------------------

Dimensions

Housing as per DIN 43880, see dimensions

Weight

With / without packaging	286g / 332g
--------------------------	-------------

Connection terminals and interfaces

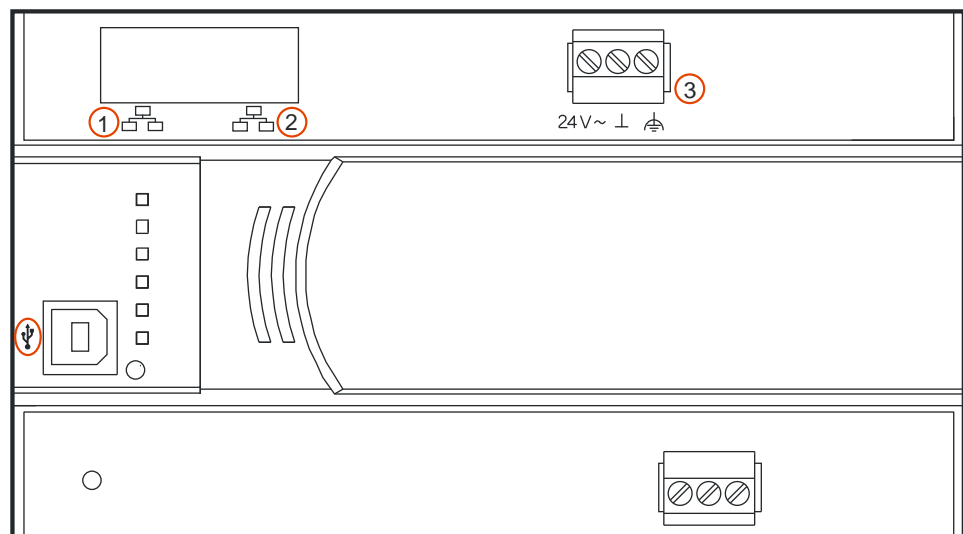

9294z04

Connection terminals

1, 2		2 x RJ45 interface for Ethernet
3		Operating voltage AC / DC 24 V
	USB	USB tool interface

Dimensions

All dimensions in mm

