



RCU10



RCU10.1

Room Temperature Controllers

RCU10...

for heating and cooling systems

Choice of two-position or modulating PI control
ON / OFF or PWM outputs for heating and cooling
Operating modes: normal operation, energy saving and standby
Operating mode selector (RCU10.1)
Operating mode changeover input for remote control
Operating voltage AC 230 V

Use

Control of the room temperature in individual rooms of ventilation or air conditioning plants that are heated or cooled with radiators, chilled ceilings, etc.

For the control of the following pieces of equipment:

- Thermic or electric valve actuators
- Damper actuators
- Electric heaters

Functions

The controller acquires the room temperature with its integrated sensor and maintains the setpoint by delivering control commands. It is possible to choose PI control with PWM actuating commands or two-position control with ON / OFF actuating commands.

The proportional band or the switching differential can be 1 or 4 K in heating mode and 0.5 or 2 K in cooling mode (selectable). The integration time cannot be adjusted and is 10 minutes. The operating sequence “Heating – cooling or heating – heating” can be selected with DIP switch no. 7.

**Function diagram
“Heating-cooling”**

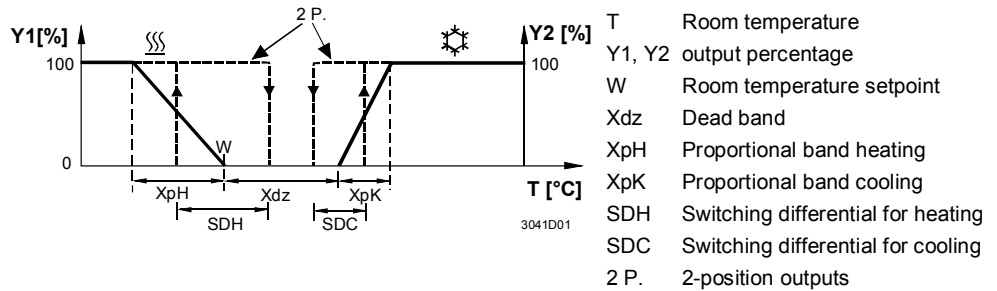

**Function diagram
“Heating-heating”
with PWM output**

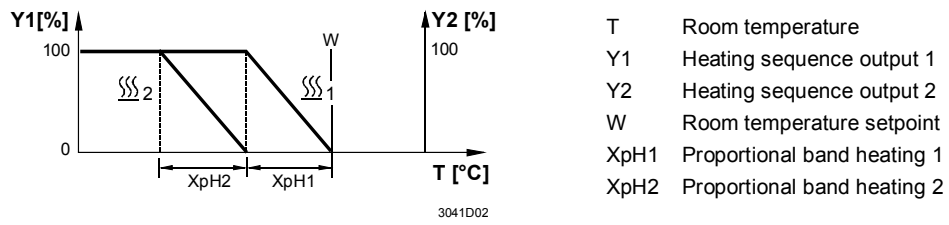

When two heating sequences are selected, the two outputs cannot be switched ON at the same time. Two outputs are switched ON separately with at least 10 seconds delay. In case of set-point change, the two heaters are allowed to switch OFF together.

**Function diagram
“Heating-heating”
with 2 position output**

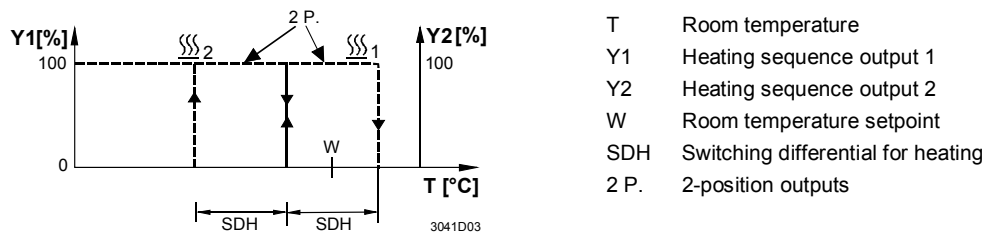

Pulse width modulation

If actuating signal “Pulse width modulation“ (PWM) is selected with DIP switches no. 5 and no. 6, the output is activated and deactivated for a certain period of time, proportional to the calculated manipulated variable and following an interval.

The interval of the PWM actuating signal can be selected as follows:

Heating and cooling (DIP switch 7 on position ON)

Y1 interval can be selected with DIP switch 8 and is either 240 s or 90 s.

Y2 interval is 240 s and cannot be changed.

Heating 2-stage (DIP switch 7 on position OFF)

Y1 interval is 240 s and cannot be changed.

Y2 interval can be selected with DIP switch 8 and is either 240 s or 90 s.

Note Output Y1 (heating): when used in connection with thermic actuators, the selected interval should be 240 seconds. When using electric heaters, it should be 90 seconds.

Caution When used in connection with electric valve actuators, DIP switches no. 5 and no. 6 must be set to ON for two-position control.

PWM actuating signals may never be used for driving electric actuators!

Energy saver The room temperature setpoint can be limited in increments of 1 K by making use of the minimum and maximum limitation facility. Arbitrary setpoint readjustments can thus be prevented.

Operating modes

The following operating modes are available:

Normal operation Normal operation is activated when the operating mode selector is set to “☀” (RCU 10.1) and the external operating mode changeover switch is not activated. In normal operation, the controller maintains the adjusted setpoint.

Frost protection mode Frost protection mode can be activated either

- by manually switching to standby (⏻) (RCU10.1)
- by activating the external operating mode changeover switch, provided DIP switch no. 1 is set to OFF

If the room temperature falls below 8 °C, the controller will automatically switch to frost protection mode. In that case, the heating valve opens and the room temperature is maintained at a setpoint of 8 °C. The setpoint adjusted by the user will be ignored.

Energy saving mode Energy saving mode can be activated either

- by manually switching to energy saving mode “☾” (RCU10.1).
- by activating the external operating mode changeover switch, provided DIP switch no. 1 is set to ON

In energy saving mode, the setpoint of heating is 16 °C and the setpoint of cooling 28 °C, independent of the position of the setpoint knob.

Operating mode changeover switch A changeover switch can be connected to status input D1–GND. When the switch activates (caused by an open window, for instance), the operating mode will change from normal operation or standby to energy saving mode (provided DIP switch no. 1 is set to ON), or from normal operation or energy saving mode to standby (provided DIP switch no. 1 is set to OFF).
The operating action of the switch (N.C. or N.O.) can be selected.

Type summary

Type reference	Features
RCU10	Without operating mode selector
RCU10.1 *)	With operating mode selector

*) Type is not orderable any more

Ordering

When ordering, please give name and type reference, e.g. room temperature controller RCU10.
Valve and air damper actuators are to be ordered as separate items.

Equipment combinations

Type of unit	Type reference	Data sheet ^{*)}
Motoric on/off actuator	SFA21...	4863
Thermal actuator (for radiator valve)	STA21...	4893
Thermal actuator (for small valve 2,5 mm)	STP21...	4878
Air damper actuators	GCA32...1	4613

*) The documents can be downloaded from <http://siemens.com/bt/download>.

Mechanical design

The unit consists of two parts:

- A plastic housing which accommodates the electronics, the operating elements and the built-in room temperature sensor
- A mounting base

The housing engages in the mounting base and snaps on.

The base carries the screw terminals. The DIP switches are located at the rear of the unit.

Setting and operating elements

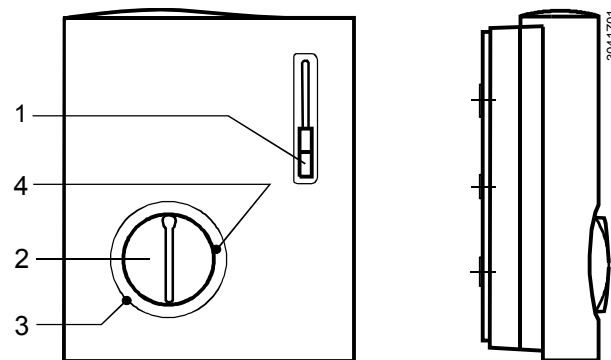

Legend

- 1 Operating mode selector (RCU10.1)
(normal operation, energy saving mode and standby)
- 2 Room temperature setpoint knob
- 3 Setting facility for minimum setpoint limitation
(in increments of 1 K)
- 4 Setting facility for maximum setpoint limitation
(in increments of 1 K)

Set of DIP switches

DIP switch no.	Meaning	Position ON	Position OFF
1	Operating mode changeover via external switch	Changeover from normal operation or standby to energy saving mode	Changeover from normal operation or energy saving to standby ¹⁾
2	Operating action of switch for external operating mode changeover	Changeover activated when contact of switch is closed (N.O.) ¹⁾	Changeover activated when contact of switch is open (N.C.)
3	Switching different or P-band	1 K in heating mode 0.5 K in cooling mode	4 K in heating mode ¹⁾ 2 K in cooling mode ¹⁾
4	Dead zone in normal operation	2 K ¹⁾	5 K
5	Signal output Y1 (heating)	ON / OFF ¹⁾	PWM
6	Signal output Y2 (heating or	ON / OFF ¹⁾	PWM

	cooling)		
7	Operating action of output Y2	Cooling ¹⁾	Heating
8	PWM signal interval for outputs heating and cooling (DIP switch 7 set on position ON) Y1 (heating) Y2 (cooling) PWM signal interval for outputs heating 2-stage (DIP switch set on position OFF) Y1 (heating) Y2 (heating)	240 s ¹⁾ 240 s (not selectable) 240 s (not selectable) 240 s ¹⁾	90 s 90 s

1) Factory setting

Accessories

Description	Type reference
Adapter plate 120 x 120 mm for 4" x 4" conduit boxes	ARG70
Adapter plate 96 x 120 mm for 2" x 4" conduit boxes	ARG70.1
Adapter plate for surface wiring 112x130 mm	ARG70.2

Notes

Check the settings of DIP switches no. 1 through no. 8 and change them, if required. If setpoint limitation is required, use the minimum and maximum limitation facility (energy saver).

After applying power, the controller makes a reset, which takes about 3 seconds. Then, it will be ready to operate.

The controller is supplied with Mounting Instructions.

Mounting location: on a wall of the room to be conditioned. Not in niches or bookshelves, not behind curtains, above or near heat sources and not exposed to direct solar radiation. Mounting height is about 1.5 m above the floor. The connecting wires can be run to the controller from a recessed conduit box.

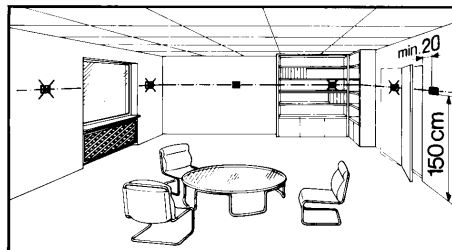

Caution AC 230 V

Mounting, installation and commissioning

Only authorized personnel may open the controller.

When mounting the unit, fix the baseplate first. Then, make the electrical connections and fit and secure the cover.

The controller must be mounted on a flat wall and in compliance with local regulations. If there are thermostatic radiator valves in the reference room, they must be set to their fully open position.



The cables used must satisfy the insulation requirements with regard to mains potential.



Warning!

No internal line protection for supply lines to external consumers (Y1, Y2)

Risk of fire and injury due to short-circuits!

- Adapt the line diameters as per local regulations to the rated value of the installed overcurrent protection device.

Maintenance

The room controller is maintenance-free.

Disposal



The devices are considered electronics devices for disposal in term of European Directive 2012/19/EU and may not be disposed of as domestic waste.

- Dispose of the device via the channels provided for this purpose
- Comply with all local and currently applicable laws and regulations.

Technical data



Power supply

Operating voltage	AC 230 V +10 %, -15 %
Frequency	50/60 Hz
Power consumption	max. 6 VA



No internal fuse

External preliminary protection with max. C 10 A circuit breaker in the supply line required under all circumstances

Functional data

Setpoint setting range	8...30 °C
Max. control deviation at 25 °C	max. ±0.7 K
Switching differential heating SDH or P-band (selectable)	1 K or 4 K
Switching differential cooling SDC or P-band (selectable)	0,5 K or 2 K
Dead zone X_{dz} in normal operation (selectable)	2 K or 5 K
Setpoint «Energy saving mode (C)», heating	16 °C
Setpoint «Energy saving mode (C)», cooling	28 °C
Setpoint «Standby (D)»	8 °C
Integration time T_n	10 min
Control outputs Y1, Y2	PWM or ON / OFF
Voltage	AC 230 V +10 % - 15 %
Current	0.02...1 A
Cycle time PWM (selectable for Y1)	240 s or 90 s
Status input D1 and GND	
Contact sensing	SELV DC 6-15 V / 3-6 mA
Insulation against mains	4 kV
Perm. cable length with copper cable 1.5 mm ² for status input D1	80 m
Operation	
Climatic conditions	to IEC 60721-3-3 class 3K5
Temperature	0...+50 °C
Humidity	<95 % r.h.
Transport	to IEC 60721-3-2
Climatic conditions	class 2K3
Temperature	-25...+70 °C
Humidity	<95 % r.h.
Mechanical conditions	class 2M2

Environmental conditions

Norms and standards	EU Conformity (CE)	CE1T3040xx ^{*)}
	RCM Conformity	CE1T3040en_C1 ^{*)}
	Degree of protection of housing	IP30 EN 60 529
	Safety class	II to EN 60 730-1
	Pollution class	normal
Environmental compatibility	The product environmental declaration CE1E3040 ^{*)} contains data on environmentally compatible product design and assessments (RoHS compliance, materials composition, packaging, environmental benefit, disposal).	
General	Connection terminals for	Use solid wires or prepared stranded wires. 2 x 1.5 mm ² or 1 x 2.5 mm ²
	Weight	
	RCU10	0.23 kg
RCU10.1	0.25 kg	
Colour of housing front	white, NCSS0502-G (RAL 9003)	

*) The documents can be downloaded from <http://siemens.com/bt/download>.

Connection terminals

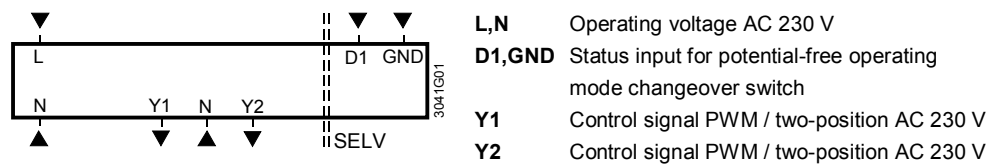

Connection diagram

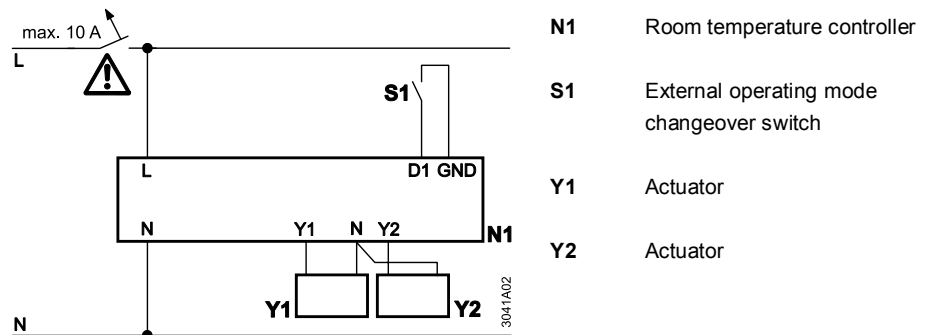

Dimensions

Controller

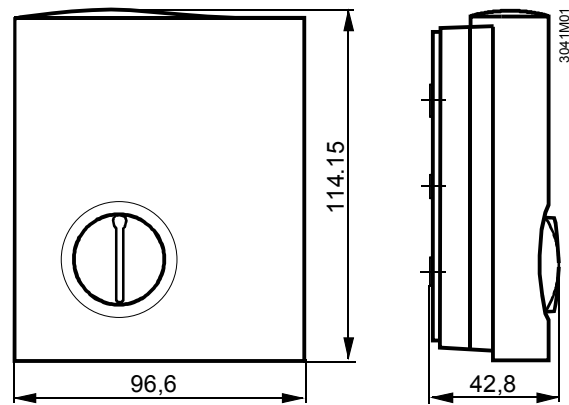

Baseplate

