

# SIEMENS



## OpenAir™ Linear actuators GEB...2 Technical basics



# Table of contents

1	Introduction .....	5
1.1	Revision history .....	5
1.2	About this document .....	5
1.3	Document contents .....	5
2	Linear actuators .....	6
2.1	Application .....	6
2.2	Type summary .....	6
2.3	Description of functions .....	7
2.3.1	Description of functions for GEB...2 .....	7
2.3.2	Supplementary information on the description of functions for GEB16..2 ....	8
2.4	Controllers .....	8
2.5	Structure and design .....	9
2.6	Setting and operator elements .....	10
3	Technical design .....	11
3.1	Motor technology .....	11
3.2	Linear travel, switches and positioning signal .....	11
3.3	Adjustable characteristic function .....	12
3.4	Neutral zone .....	13
4	Engineering notes .....	14
4.1	Safety notes .....	14
4.2	Device-specific regulations .....	15
4.3	Notes on EMC optimization .....	16
4.4	Determining the linear actuator .....	16
5	Mounting notes .....	17
6	Wiring notes .....	18
6.1	Permissible line lengths and cross-sectional areas .....	18
6.2	Actuator wiring (three-position) .....	20
6.3	Actuator wiring (modulating) .....	21
7	Commissioning notes .....	22
7.1	General checks .....	22
7.2	Electrical function check .....	22
8	Technical data .....	24
9	Diagrams .....	26

9.1	Internal diagrams .....	26
9.2	Cable labeling .....	26
9.3	Connection diagrams (three-position control) .....	27
9.4	Connection diagrams (modulating) .....	28
9.4.1	Typical application.....	28
9.4.2	Special switchings for modulating control .....	28
10	Environmental compatibility and disposal .....	29
11	Appendix .....	30
11.1	Dimensions .....	30
11.2	Referenced documents .....	30

# 1 Introduction

## 1.1 Revision history

---

Changes	Date	Chapter	Pages
Types GEB132.2E / 332.2E / 164.2E / 166.2E removed	16.09.2013	all	whole Document
ASK75.6 inserted	16.09.2013	2.2 / 11.2	6 / 31
Electrical parallel connection of actuators	15.02.2005	4.2	15
Required linear actuator (GEB...2)		4.4	16
Permissible line lengths and cross-sectional areas		6.1	18/19
Environmental compatibility and disposal		10	29
Referenced documents		11.2	30/31

## 1.2 About this document

---

Main audience	This document targets engineering, product management, and commissioning staff in the market areas.
Purpose	This document provides basic knowledge. In addition to background information, it contains general technical fundamentals on the GEB...2 linear actuator series. It offers all information on engineering, correct mounting and wiring, commissioning, and service.
Referenced documents	Chapter 11.2 "Referenced documents " contains a list of documents on rotary and linear actuators with accessories.

## 1.3 Document contents

---

This document contains basic technical information on type series GEB...2 for:

- Three-position control and
- Modulating control.

The following topics are discussed:

- Type overview and description of the available options.
- Applications and functions.
- Actuator design including setting and operator elements.
- Adjustable auxiliary switches and characteristic function.
- Notes on engineering and safety-specific guidelines and regulations.
- Notes on mounting, wiring, and commissioning.
- Technical data
- Diagrams
- Environmental compatibility and disposal

## 2 Linear actuators

### Introduction

This chapter provides information on application, functions, and device combinations. Furthermore, it contains a type overview and explains the actuator design including setting and operator elements for this family of actuators.

### 2.1 Application

The linear actuators are used in ventilating and air conditioning plants to operate rotary and linear dampers :

- For damper areas up to 3 m<sup>2</sup>, friction-dependent.
- Suitable for modulating controllers (DC 0...10 V) or three-position controllers (e.g. rotary and linear dampers at air outlets).

### 2.2 Type summary

The following table shows the options for the linear actuator types.

GEB...	131.2E	136.2E	331.2E	336.2E	161.2E	163.2E
Control type	Three-position control				Modulating control.	
Operating voltage AC 24 V	X	X			X	X
Operating voltage AC 230 V			X	X		
Positioning signal Y DC 0...10 V					X	X
DC 2...10 V					X	
DC 0...35 V with characteristic function						X
Position indicator U = DC 0...10 V					X	X
Self-adaptation of linear travel range					X	X
Auxiliary switches (two)		X		X		
Linear travel direction switch					X	X

### Accessories

For functional enhancements of the actuators, the following accessories are available:

Linear/rotary set with mounting plate

**ASK72.3**

Weather Shield for actuators

**ASK75.6**

Data sheet for accessories

**N4697**

## 2.3 Description of functions

### 2.3.1 Description of functions for GEB...2

The functions are listed in a table and are assigned to the respective control types.

Type	GEB13..2 / GEB33..2	GEB16..2
Control type	Three-position control	Modulating control.
Positioning signal with adjustable characteristic function		DC 0...35 V with offset $U_0 = 0...5$ V and span $\Delta U = 2...30$ V
Linear travel, Linear travel direction	The direction of linear travel depends:	
	On the type of control. With no power applied, the actuator remains in the respective position.	<ul style="list-style-type: none"> <li>On the direction of the DIL linear travel direction switch.</li> <li>On the positioning signal.</li> </ul> The actuator stays in the position reached: <ul style="list-style-type: none"> <li>If the positioning signal is maintained at a constant value.</li> <li>If the operating voltage is interrupted.</li> </ul>
Position indication: Electrical		<ul style="list-style-type: none"> <li>Position indicator: Output voltage <math>U = DC 0...10</math> V is generated proportional to the linear travel.</li> <li>The direction of action (inverted or not inverted) of output voltage <math>U</math> depends on the linear travel direction of the DIL switch.</li> </ul>
Self-adaptation of linear travel range		<ul style="list-style-type: none"> <li>Automatically determines the end position of the linear travel range.</li> <li>The characteristic function (<math>U_0, \Delta U</math>) is mapped to the determined linear travel range.</li> </ul>
Auxiliary switches	The switching points for auxiliary switches A and B can be set independent of each other in increments of 3.2 between 3.2 and 56.8 mm.	
Response on damper blocking		The actuator is equipped with an automatic switch-off mechanism.
Manual adjustment	The push rod can be manually adjusted by pushing the gear train disengagement button.	

## 2.3.2 Supplementary information on the description of functions for GEB16..2

The following information applies to **modulating** actuators.

### Characteristic function (GEB163.2)

Offset  $U_0$  and span  $\Delta U$  can be adjusted using two potentiometers (see 3.3 "Adjustable characteristic function"). The maximum permissible input voltage ( $U_0 + \Delta U$ ) is DC 35 V.

### Application

Actuators featuring this function can be used for the following applications:

- Dampers with a linear travel limitation, for instance in the 0...30 mm range, can be controlled using the full positioning signal range DC 0...10 V.
- As a sequencing actuator in control loops that can only apply a DC 0...10 V positioning signal to control more than one sequence.
- In control systems with a positioning signal deviating from DC 0...10 V such as DC 2...10 V or DC 0...35 V.

### Self-adaptation of the linear travel range (GEB16..2)

The actuator automatically determines the mechanical end of range for the linear travel on:

- Activated self-adaptation and switching-on of operating voltage.
- Switch-on and switch-off for self-adaptation when operating voltage is supplied.

The table shows the different effects of the characteristic function's mapping to the linear travel range for "inactive self-adaptation" and "active self-adaptation" (see also chapter 3.3 "Adjustable characteristic function").

Inactive self-adaptation	Active self-adaptation
<ul style="list-style-type: none"> <li>• The actuator maps the characteristic function (<math>U_0, \Delta U</math>) to the positioning range <math>Y_s = 100\%</math> for the <b>linear travel range of 57 mm</b>.</li> <li>• The actuator calibrates the position indication with <math>U = DC\ 0...10\ V</math> for the <b>linear travel range of 57 mm</b>.</li> </ul>	<ul style="list-style-type: none"> <li>• The actuator maps the characteristic function (<math>U_0, \Delta U</math>) to the positioning range <math>Y_s = 100\%</math> for the <b>determined linear travel range</b>.</li> <li>• The actuator calibrates the position indication with <math>U = DC\ 0...10\ V</math> for the <b>determined linear travel range</b>.</li> </ul>

## 2.4 Controllers

The actuators can be connected to all controllers having the following outputs. All safety-related requirements must be fulfilled (see chapter 4 "Engineering notes").

Actuator type	Control type	Controller output
GEB13..2	Three-position	AC 24 V
GEB33..2	Three-position	AC 230 V
GEB16..2	Modulating	DC 0...10 V / DC 2...10 V / DC 0...35 V



## 2.5 Structure and design

---

Description	The electronic motor-driven GEB..2 linear actuators are available for three-position and modulating control. The nominal linear force is 400 N. The actuator has prewired connection cables.
Housing	Robust, light-weight full metal housing from aluminum diecast. The housing guarantees a long actuator life even under harsh environmental conditions.
Gear train	Maintenance-free and noise-free gear train with stall and overload protection for the life of the actuator.
Manual adjustment	When no voltage is supplied, you can manually adjust the actuator or the air damper by pressing the gear train disengagement button.
Electrical connection	All actuators have pre-wired, 0.9 m long (standard length) connection cables.

<b>Type-specific elements</b>	The actuators can be delivered as a type-specific variant having the following elements:
Auxiliary switches	For supplementary functions, you can adjust auxiliary switches A and B on the actuator front.
Potentiometer for offset and span	Both potentiometers for the characteristic functions $U_0$ and $\Delta U$ are accessible on the front.
DIL switch (only for GEB16..2)	The DIL switches exist only in modulating actuators and are accessible from the front.
DIL switch cover (only for GEB16..2)	This cover protects the DIL switch against dust and water spray.

## 2.6 Setting and operator elements

### Linear actuator

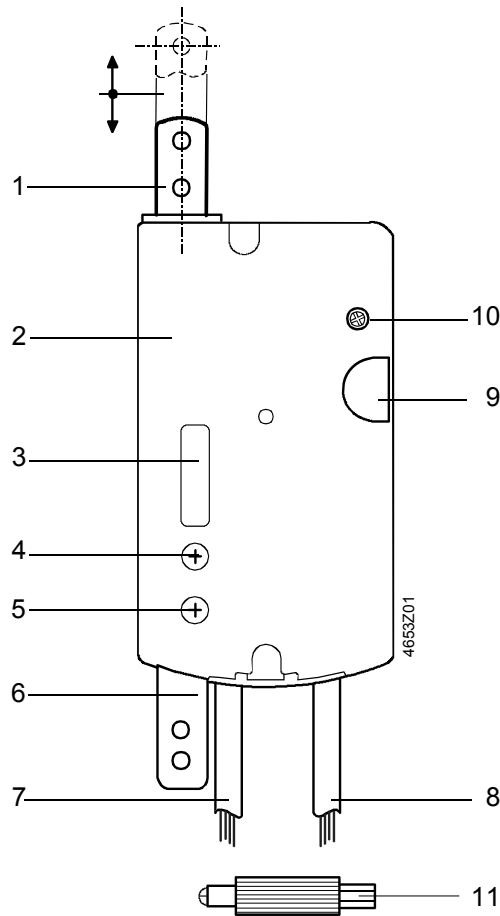

#### Legend

- 1 Push rod
- 2 Housing
- 3 DIL switch and cover
- 4 Potentiometer to adjust the span  $\Delta U$
- 5 Potentiometer to set the offset  $U_o$
- 6 Mounting bracket
- 7 Connecting cable for power and positioning signal
- 8 Connecting cable for auxiliary switches
- 9 Disengagement button for gear train
- 10 Setting shafts for auxiliary switches A and B
- 11 Adjustment tool for auxiliary switches (10) and potentiometer (4, 5)

### DIL switch

(Legend pos. 3)  
GEB16..2

Meaning	DIL switch label		Meaning	Function
Outward travel	↑	<input type="checkbox"/>	↓	Inward travel
Active	↔	<input type="checkbox"/>	0	Off
DC 2...10 V	2...	<input type="checkbox"/>	0...	DC 0...10 V
DC 0...35 V (Comfort)	C	<input type="checkbox"/>	0	DC 0...10 V

Note

Factory setting for DIL switch.

# 3 Technical design

## Introduction

This chapter discusses the following topics:

- Motor technology
- Adjustable auxiliary switches.
- Adjustable characteristic function (positioning signal, DC 0...35 V).
- Control characteristics by including neutral zone.

## 3.1 Motor technology

### Motor technology

A synchronous motor enables accurate speed control. The magnetic coupling serves as linear force supervision to protect both actuator and dampers.

## 3.2 Linear travel, switches and positioning signal

### Mechanical and electrical functions

The illustration below shows the relationship between the linear travel, the adjustable switching points for auxiliary switches A and B and the positioning signal.

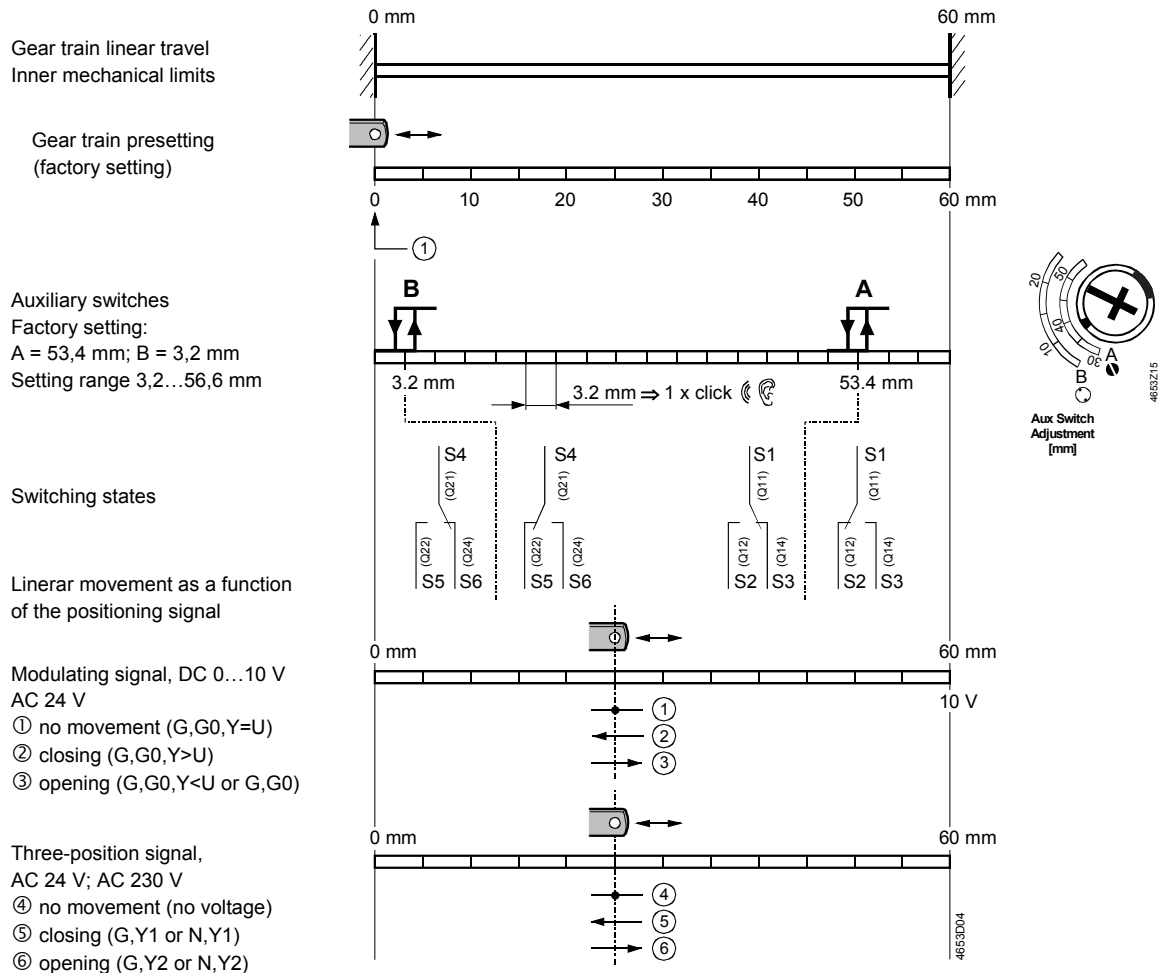

Note

The setting shafts for the auxiliary switches turn together with the actuator. The scales are valid only for the **zero position of the actuator** (push rod in) on **"outward"** linear travel.

Adjustment tool

The adjustment tool is used to set the auxiliary switches; it is part of the delivery (type-specific).

### 3.3 Adjustable characteristic function

**Actuators**  
GEB163.2

A modulating positioning signal DC 0...35 V from a controller controls the actuator. The linear travel is proportional to the positioning signal. Using potentiometer "Uo", you can set the offset for DC 0...5 V, and with potentiometer "ΔU", you can set the span for DC 2...30 V.

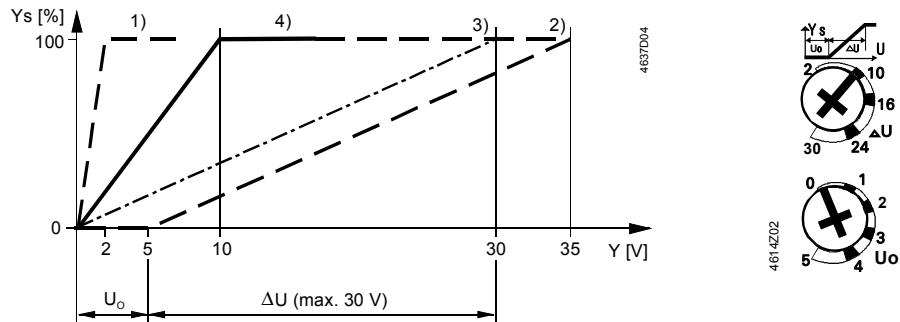

- Ys Positioning range
  - For inactive self-adaptation: 100 % = linear travel range 57 mm
  - For active self-adaptation: 100 % = determined linear travel range
- Y Positioning signal
- Uo Offset
- ΔU Span (for  $Y_s = 100$  %)

Examples as per the diagram

Example	Positioning signal Y	Pos. range Ys	Settings	
			Uo	ΔU
1)	DC 0...2 V	0...100 %	DC 0 V	DC 2 V
2)	DC 5...10 V	0...17 %	DC 5 V	DC 30 V
	DC 5...35 V	0...100 %		
3)	DC 0...10 V	0...33 %	DC 0 V	DC 30 V
	DC 0...30 V	0...100 %		
4)*	DC 0...10 V	0...100 %	DC 0 V	DC 10 V

4)\* Characteristic curve for factory setting

Note

The Y input is limited to max. DC 35 V.  
The adjustable span  $\Delta U$  is max. 30 V.

**Example**

Define the adjustable span  $\Delta U$  if the actuator is to open from 0...50 % at a positioning signal of  $Y = DC 2...10$  V. The offset  $U_o$  thus amounts to 2 V. The linear travel range is 57 mm. Self-adaptation is inactive.

Formula

Calculating the setting value for  $\Delta U$ :

$$\Delta U = \frac{\text{max. pos. range } Y_s \text{ max } [\%]}{\text{span pos. range } Y_s [\%]} \cdot (10 \text{ [V]} - U_o \text{ [V]}) = \frac{100 \%}{50 \%} \cdot (10 \text{ V} - 2 \text{ V}) = 16 \text{ V}$$

Potentiometer settings

**Uo = 2 V, ΔU = 16 V**

Characteristic function for example

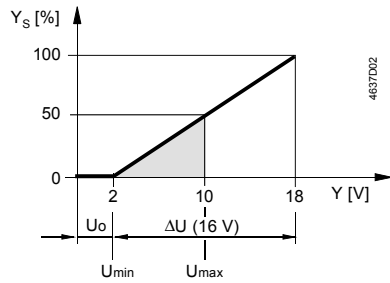

Max. positioning range  $Y_{smax} = 100\%$  (57 mm)  
 Span range  $Y_s = 50\%$  (28.5 mm)  
 Offset  $U_0 = 2\text{ V}$   
 Span  $\Delta U = 16\text{ V}$

Effective span  
 $\Delta U_w = U_{max} - U_{min}$   
 $= 10\text{ V} - 2\text{ V} = 8\text{ V}$

### 3.4 Neutral zone

**Actuators**  
 GEB16...2 (DC 0...10 V)

For modulating control actuators, note the control characteristic for the selected switch-on point of the setpoint. The diagram shows the setting characteristics by including the neutral zone for range DC 0...10 V.

*Note*

The diagram shows the setting characteristics by including the neutral zone. The values for the neutral zone listed in the diagram apply to DC 0...10 V (**without characteristic function**) and if the linear travel direction is set to "outward travel".

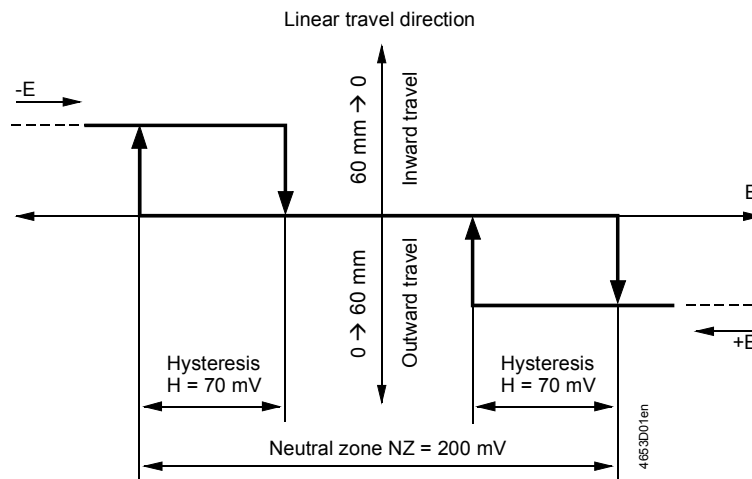

**Actuators**  
 GEB163.2,  
 (DC 0...35 V)

For DC 0...35 V (**with characteristic function**) the following values apply:  
 Neutral zone  $NZ = 2\%$  of span  $\Delta U$ .  
 Hysteresis  $H = 0.7\%$  of span  $\Delta U$ .

## 4 Engineering notes

---

Introduction

Carefully study the basics of the control systems used before proceeding to the sections below, and pay special attention to all safety-related information.

Intended use

Use these actuators in a system only for applications as described in the basic system documentation of the control systems used. Additionally, note the actuator-specific properties and conditions as described in this chapter and in chapter 8 "Technical data" in this document.

### 4.1 Safety notes

---



Please observe the following notes

This chapter explains general and system-specific regulations for mains and operating voltages. It also contains important information regarding your own safety and that of your plant.



Safety note

The warning triangle to the left means that you must observe all respectively listed regulations and notes. If ignored, injuries and equipment damages may result.



General regulations

Observe the following general regulations during engineering and project execution:

- Electric and high-power regulations of the respective country.
- Other mandatory country regulations.
- House installation regulations of the respective country.
- Regulations by the energy supplier.
- Diagrams, cable lists, dispositions, specifications, and instructions as per the customer or the engineering company.
- Third-party regulations from, e.g., the general contractors or building contractors.

Safety

Electrical safety in Siemens building management and control systems primarily depends on **extra-low voltage with safe isolation from mains voltage**.

SELV, PELV

Depending on the earthing of extra-low voltage, SELV or PELV applications as per HD384 "Electrical plants in buildings" result:

**Unearthed** = Safety Extra-Low Voltage **SELV**

**Grounded** = Protection by Extra-Low Voltage **PELV**



Earthing of G0 (system neutral)

Observe the following for grounding G0:

- As a rule, earthing as well as non-earthing of G0 is permissible for AC 24 V operating voltage. However, observe all local regulations and customary procedures.
- For functional reasons, earthing may be required or not permissible.

*Recommendation on earthing G0*

- **As a rule, ground AC 24 V systems** if not otherwise indicated by the manufacturer.
- To avoid earth loops, connect systems with **PELV** to the earth at **only one end** in the system - normally at the transformer - unless otherwise specified.

 Operating voltage  
AC 24 V, AC 230 V

The following regulations apply to these operating voltages:

	Regulation
Operating voltage AC 24 V	The operating voltage must comply with the requirements for SELV or PELV: <ul style="list-style-type: none"> <li>• Permissible deviation of AC 24 V nominal voltage at the actuators: +/-20 %.</li> </ul>
AC 230 V	Permissible deviation of AC 230 V nominal voltage at the actuators: +/-10 %.
Specification on AC 24 V transformers	<ul style="list-style-type: none"> <li>• Safety transformers as per EN 61558, with double isolation, designed for 100 % runtime to supply SELV or PELV circuits.</li> <li>• Determine the transformer's power consumption by adding up the power consumption in VA for all actuators used.</li> <li>• The capacity used from the transformer should amount to at least 50 % of the nominal load for efficiency reasons (power efficiency).</li> <li>• The nominal capacity of the transformer must be at least 25 VA. For smaller transformers, the ratio between voltage at idle time to voltage at full load is unsatisfactory (&gt; + 20 %).</li> </ul>
Fuse of AC 24 V operating voltage	Transformers, secondary side: <ul style="list-style-type: none"> <li>• According to the effective load of all connected devices.</li> <li>• Line G (system potential) must always be fused.</li> <li>• Where required, additional line G0 (system neutral).</li> </ul>
Fuse of AC 230 V mains voltage	Transformers, primary side, as per the applicable installation regulations of the respective country.

## 4.2 Device-specific regulations

 Device safety

Safety for the devices is ensured by (among other aspects):

- Supply of AC 24 V extra-low voltage as per **SELV** or **PELV**.
- Double isolation between AC 230 V mains voltage and SELV/PELV circuits.

 Auxiliary switches A, B

Apply **only mains voltage** or **only safety extra-low voltage** to the switching outputs of auxiliary switches A and B. Mixed operation is not permissible. However, operation using various phases is permissible.

Electrical parallel  
connection of actuators

Up to 10 actuators of the same device type can be electrical parallel wired. Cable length and cable cross section have to be respected.

See chapter 6, "Wiring notes".



Caution,  
maintenance

Do not open the actuator.

The device is maintenance-free.

Only the manufacturer may conduct any repair work.

### 4.3 Notes on EMC optimization

---

Running cables in a duct	Make sure to separate high-interference cables from equipment susceptible to interference.
Cable types	<ul style="list-style-type: none"><li>• Cables emitting interference: Motor cables, particularly motors supplied by variable speed drives, energy cable.</li><li>• Cables susceptible to interference: Control cables, extra-low voltage cables, interface cables, LAN cables, digital and analog signal cables.</li></ul>
Cable segregation	<ul style="list-style-type: none"><li>• You can run both cable types in the same cable ducting, but in different compartments.</li><li>• If ducting with three closed sides and a partition is not available, separate the interference-emitting cables from other cables by a minimum of 150 mm or route in separate ducting.</li><li>• Cross high-interference cables with equipment susceptible to interference only at right angles.</li><li>• When, as an exception, signal and interference-emitting supply cables are run in parallel, the risk of interference is very high. In this case, limit the cable length of the positioning signal line DC 0...10 V for modulating actuators.</li></ul>
Unshielded cables	We recommend to use unshielded cables. When selecting unshielded cables, follow the manufacturer's installation recommendations. In general, <b>unshielded twisted-pair</b> cables have sufficient EMC characteristics for building services (incl. data applications) as well as the advantage that no provision is required for coupling to the surrounding earth.

### 4.4 Determining the linear actuator

---

Required linear actuator	To determine the linear actuator, define the required total torque for the damper system. The total torque and the given construction allow you to determine the linear force. The type of actuator then results from the table:
--------------------------	--

If the linear force is	then use type
≤ 125 N	GDB...2 (max. 180 N)
≤ 250 N	GLB...2 (max. 350 N)
≤ 400N	GEB...2 (max. 800 N)
≤ 550 N	GBB...2 (max. 1100 N)



## 5 Mounting notes

---

Mounting instructions	All information and steps to properly prepare and mount the actuator are available in the mounting instructions 4 319 0110 0 (M4653) delivered with the actuator.
Mounting position	Choose the actuator's mounting position so that you can easily access the cables as well as the setting dials on the front of the actuator. Refer to 11.1 "Dimensions".
Device protection	Degree of protection class is IP40
Linear force support	<ul style="list-style-type: none"><li>• Rotary damper application: To support the linear force a stable support for the actuator in accordance with the mounting instructions is required.</li><li>• Linear damper application: Secure the actuator using two taptite M6 screws.</li></ul>
Manual adjustment	You can manually adjust the push rod can by pressing the gear train disengagement button. To ensure a tight close-off function for the dampers and the exact switching position for switches A and B, adjust the actuator only if not voltage is applied.
Mechanical limitation of linear travel	If needed, you can limit the linear travel by selecting a specific damper level length or by using the linear/rotary set ASK72.3.
Application of the linear/rotary sets	Mount the sets to convert a rotary movement to linear movement (chapter 2.2 "Type summary") by following the separate mounting instructions.

# 6 Wiring notes

Introduction

Prior to wiring, study all information in the following sections:

- "Safety notes" in chapter 4.1
- "Device-specific regulations" in chapter 4.2
- "Notes on EMC optimization" in chapter 4.3,
- "Diagrams" in chapter 9, and the
- HVAC plant diagram.

## 6.1 Permissible line lengths and cross-sectional areas

The line lengths and cross-sectional areas depend on the actuators power consumption and the permissible voltage drop of the connection lines to the actuators. Determine the necessary line length from the following diagram and the formulas.

Note

To determine the permissible line length, adhere to the permissible operating voltage tolerance at the actuator (see chapter 8, "Technical data") in addition to the permissible voltage drop between the signal and supply lines (see table below).

Permissible voltage drop

The line sizing between the controller and the actuators depends on the actuator type used and is determined on the following basis.

Type	Operating voltage	Line	Max. permissible voltage drop
GEB13..2	AC 24 V	G, Y1, Y2	4 % each (tot. 8 %) of AC 24 V
GEB16..2	AC 24 V	G0, G G0, Y, U	4 % each (tot. 8 %) of AC 24 V 1 % each of DC 10 V
GEB33..2	AC 230 V	L, N	2 % each (tot. 4 %) of AC 230 V

Notes on the G0 line  
(GEB16..2)

Consider the following criteria:

- For modulating control:  
The permissible positioning signal error caused by a voltage drop in the line current on the G0 line must not exceed 1%.
- The G0 line's voltage drop caused by surges in the DC circuit in the actuator may not exceed 2 Vpp.
- In the case of improper sizing of the G0 line, actuator load changes may cause natural oscillation due to a change in the DC voltage drop.
- The supply voltage loss at AC 24 V may not exceed 8% (4% over G0 line).
- DC voltage drop over the G0 line is caused as follows:
  - Asymmetrically in the internal actuator supply (ca. DC 8 mA).
  - Positioning signal current DC 0.1 mA (from Y = DC 10...10 V).
  - Positioning signal current DC 1 mA (from U = DC 0...10 V).

**It can be ignored for the following aspects.**

**Line length/consumption  
AC 24 V**

The diagram applies to AC 24 V and shows the permissible line length **L** as a function of consumption **P** and as a parameter of the line cross sections.

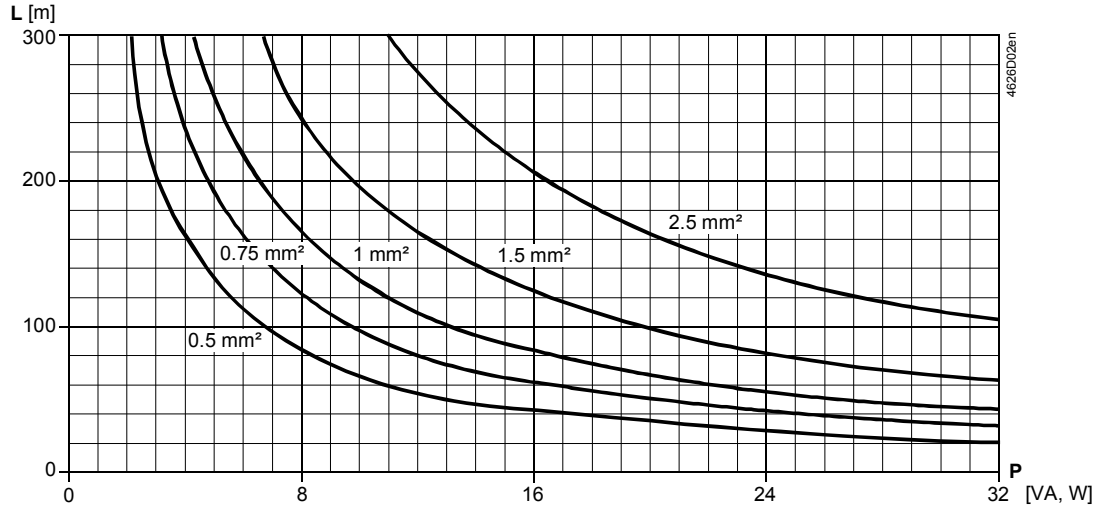

**Notes on diagram**

- The values in [VA, W] on the P-axis are allocated to the permissible voltage drops ( $\Delta U/2U = 4\%$ ) on line L as per the above table and to the P&I diagram.
- P is the primary power consumption for all actuators connected in parallel.

P&I diagram:  
Voltage drop on the supply lines

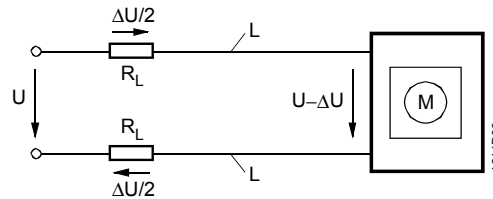

**Formula for line length**

The maximum line length can be calculated using the following formula.

Operating voltage	Perm. voltage drop/line	Formula for line length
AC 24 V	4 % of AC 24 V	$L = \frac{1313 \cdot A}{P}$ [m]
	1 % of DC 10 V	$L = \frac{5.47 \cdot A}{I(DC)}$ [m]
AC 230 V	2 % of AC 230 V	$L = 46 \cdot \frac{1313 \cdot A}{P}$ [m]

- A Line cross section in [mm<sup>2</sup>]
- L Permissible line length in [m]
- P Power consumption in [VA] or [W];  
The value is printed on the actuator's type plate.
- I(DC) DC current portion in line G0 in [A]

**Line length for actuators connected in parallel**

The following sections show how to determine the permissible line length and cross sections for the various actuators based on examples.

The examples for actuators connected in parallel apply to the following arrangement:

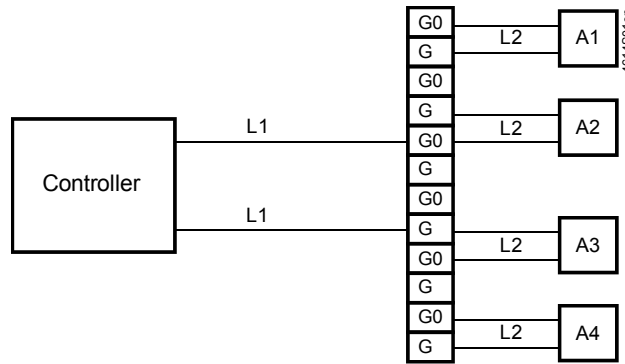

Assumption

The line resistances of L2 are equal and can be ignored for L1. Separately calculate the permissible line lengths L2 for other connections (ring, star-like).

## 6.2 Actuator wiring (three-position)

**Actuators with three-position control**  
GEB13..2

In three-position actuators, only the situation as presented under **AC 24 V** is important. Sizing occurs via lines 1 (G), 6 (Y1), and 7 (Y2).

Power consumption and perm. voltage drop with one actuator

The table shows the main power consumption of an actuator as well as the permissible voltage drop.

Operating voltage/ positioning signal	Power consumption	Perm. voltage drop for line 1 (G), 6 (Y1), 7 (Y2)
AC 24 V	3.5 VA	$\Delta U/U = \text{max. } 8\%$ (4 % each per line)

P&I diagram:  
Conduction currents at  
AC 24 V

The diagram shows the currents in the connecting lines for **one actuator**.

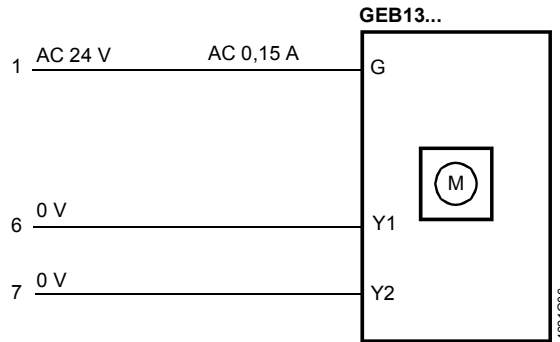

**Example:**  
Parallel connection of two  
actuators

Determining the line lengths for two actuators GEB13..1 and AC 24 V supply. Only the currents in line 1 (G) and 6 (Y1) or 7 (Y2) determine the line sizing. Max. permissible voltage drop = **4% per line** (total 8 %).

- Consumption = 2 x 3.5 VA = 7 VA.
- Line current = 2 x 0.15 A = 0.3 A.

Max. permissible single line length: 280 m at 1.5 mm<sup>2</sup> line cross section.

## 6.3 Actuator wiring (modulating)

### Modulating actuators GEB16..2

With AC supply, the G0 line has a AC 0.23 A supply current and a DC 0.1 mA positioning signal current (from Y = DC 0...10 V). The AC voltage drop on the G0 line does not impact the positioning signal Y.

Power consumption and perm. voltage drop with one actuator

Operating voltage	Power consumption	Perm. voltage drop for line
		1 (G), 2 (G0)
AC 24 V	5,5 VA	4 % of AC 24 V

P&I diagram:  
Conduction currents

The diagram shows the currents in the connecting lines for **one actuator**.

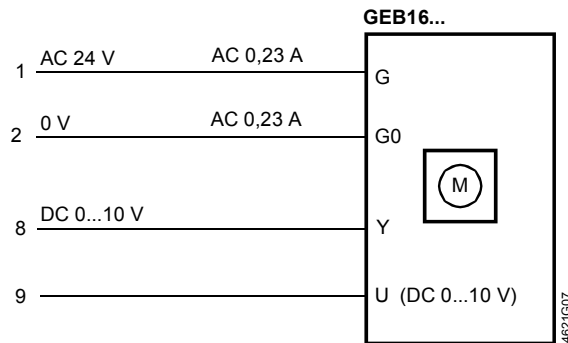

**Example:**  
Parallel connection of four actuators

Determining the line lengths for four actuators GEB16..1 and AC 24 V supply. Only the AC currents in line 1 (G) and 2 (G0) determine the line sizing.  
Max. permissible voltage drop = **4% per line**.

- Consumption =  $4 \times 5.5 \text{ VA} = 22 \text{ VA}$ .
- Line current =  $4 \times 0.23 \text{ A} = 0.92 \text{ A}$ .
- **Permissible single line length for G, G0:**  
90 m at  $1.5 \text{ mm}^2$  line cross section, or  
149 m at  $2.5 \text{ mm}^2$  line cross section.

# 7 Commissioning notes

## References

All information necessary for commissioning is contained in the following:

- This document ("Technical basics" Z4653en).
- Mounting instructions 74 319 0110 0 (M4653).
- HVAC plant diagram.

## 7.1 General checks

### Environmental conditions

Check to ensure that all permissible values as contained in chapter 8 "Technical data" are observed.

### Mechanical check

- Check for proper mounting and to ensure that all mechanical settings correspond to the plant-specific requirements. Additionally, ensure that the dampers are shut tight when in the closed position.
- Linear movement check: Manually change the damper setting by pressing the gear train disengagement button and moving the push rod (only if not voltage is applied).
- Linear force support: Make sure the actuator's fastenings are stable at the maximum possible tight close-off of the dampers.

### Electrical check

- Check to ensure that the cables are connected in accordance with the plant wiring diagram.
- The operating voltage AC 24 V (SELV/PELV) or AC 230 V must be within the tolerance values.

## 7.2 Electrical function check

### Linear movement: Three-position control GEB13..2, GEB33..2

Check the actuator operating states as follows (see also chapter 9.3 "Connection diagrams (three-position control)").

Wire connections		Linear travel direction
AC 24 V	AC 230 V	
1 – 6	4 – 6	Inward travel
1 – 7	4 – 7	Outward travel
1 – 6 / 1 – 7 open	4 – 6 / 4 – 7 open	Actuator stays in position reached.

### Linear movement: Modulating control GEB16..2

Check the actuator operating states as follows (see also chapter 9.4 "Connection diagrams (modulating)"):

- When applying input signal  $Y = DC 10 V$ , the push rod travels inward or outward depending on the DIL switch setting.
- The linear travel direction set at the DIL switch must match the desired damper movement direction.
- After interrupting the AC 24 V operating voltage, the actuator stops.
- After interrupting positioning signal  $Y$ , but while operating voltage is still supplied, the push rod returns to its zero position.

### Characteristic function for the positioning signal GEB163.2

Factory setting: The potentiometers for setting the offset  $U_0$  and span  $\Delta U$  are set to the following values:  $U_0 = 0 V$ ,  $\Delta U = 10 V$ .

### Note

Specify the values set for  $U_0$  and  $\Delta U$  in the plant papers.

### Position indicator

GEB16..2

Check of output voltage U:

- For inactive self-adaptation: U = DC 0...10 V for the **linear travel range of 57 mm**.
- For active self-adaptation: U = DC 0...10 V for the **determined linear travel range**.

### Auxiliary switches A and B

- Switchover of the auxiliary switch contacts "A" and "B" as soon as the actuator reaches the respective switching positions.
- Set the setting shafts (part of the delivery) to the desired value by means of the adjustment tool. (See chapter 3.2, "Linear travel, switches".)

### Important

The scale values are valid only for the **zero position** of the actuator in the **"outward"** direction of linear travel.

### Factory setting

The auxiliary switches have the following factory settings:

- Switch A: Switching point at 3.2 mm.
- Switch B: Switching point at 53.7 mm.

### DIL switch

for GEB16..2

Use the three DIL switches to check the functions of these actuators.

### Linear travel direction



- The set linear travel direction must match the desired damper movement direction.
- Factory setting:
- Also check the operating states for special switchings as per chapter 9.4.2.

### Self-adaptation



- Alternative switch-on/switch-off of self-adaptation.
- $\leftarrow\rightarrow$ : ON
- 0: OFF
- Factory setting: 0.

### Positioning signal without characteristic function: (GEB161.2)



- Alternate setting:
- 2.: DC 2...10 V
- 0.: DC 0...10 V
- Factory setting: 0.

### Positioning signal with/without characteristic function: (GEB163.2)



- Alternate setting:
- C: DC 0...35 V (Comfort, with characteristic function)
- 0: DC 0...10 V (without characteristic function)
- Factory setting: 0.

## 8 Technical data

**!** AC 24 V power supply  
(SELV/PELV)  
GEB13..2, 16..2

Operating voltage	AC 24 V ± 20 %
Frequency	50/60 Hz
Safety extra-low voltage (SELV) or Protection by extra-low voltage (PELV) as per	HD 384
Requirements for external safety insulating transformer (100 % duty)	as per EN 61558
Supply line fuse	max. 10 A
Power consumption	
GEB13..2: Actuator operational	4 VA / 3,5 W
GEB16..2: Actuator operational	6 VA / 5.5 W
Holding	1.5 W

**!** AC 230 V power supply  
GEB33..2

Operating voltage	AC 230 V ± 10 %
Frequency	50/60 Hz
Supply line fuse	max. 10 A
Power consumption:	Actuator operational
	3 VA / 3 W

Function data

Nominal linear force	400 N
Maximum linear force (blocked)	800 N
Minimum holding torque	400 N
Nominal travel	57 mm
Maximum linear travel (mechanical limitation)	60 mm
Runtime for 57 mm linear travel	150 s
Mechanical life	10 <sup>5</sup> cycles

**!** Inputs

Positioning signal for GEB13..2

Operating voltage AC 24 V (wires 1-6)	Outward travel
(wires 1-7)	Inward travel

Positioning signal for GEB33..2

Operating voltage AC 230 V (wires 4-6)	Outward travel
(wires 4-7)	Inward travel

Positioning signal for GEB16..2

Input voltage (wires 8-2)	DC 0...10 V / 2...10 V
Current consumption	0,1 mA
Input resistance	> 100 kΩ
Max. permissible input voltage	DC 35 V
Protected against faulty wiring	max. AC 24 V
Neutral zone	
for non-adjustable characteristic function	200 mV
for adjustable characteristic function	2 % of ΔU
Hysteresis	
for non-adjustable characteristic function	70 mV
for adjustable characteristic function	0.7 % of ΔU

Adjustable characteristic  
function for GEB163.2

Adjustable with 2 potentiometers:	
Offset U <sub>0</sub>	DC 0...5 V
Span ΔU for Y <sub>s</sub> = 100 %	DC 2...30 V
Max. input voltage	DC 35 V
Protected against faulty wiring	max. AC 24 V

**!** Outputs



Position indicator  
for GEB16...2

Output signal (wires 9-2)	
Output voltage (for Y <sub>s</sub> = 0...100 %)	DC 0...10 V
Max. output current	DC ± 1 mA
Protected against faulty wiring	max. AC 24 V





Auxiliary switches  
for GEB136.2, GEB336.2

	Contact rating	6 A resistive, 2 A inductive
	Life:	6 A resistive, 2 A inductive 5 A resistive, 1 A inductive without load
	Switching voltage	AC 24...230 V
	Nominal current resistive/inductive	6 A / 2 A
	Electric strength auxiliary switch against housing	AC 4 kV
	Switching range for auxiliary switches	3.2...56.8 mm
	Setting increments	3.2 mm
	Switching hysteresis	2 mm
	Factory switch setting	
	Switch A	3.2 mm
	Switch B	53.7 mm
Connection cables	Cross section of prewired connection cables	0.75 mm <sup>2</sup>
	Cable length	0.9 m
	Permissible length for signal lines	300 m (see chapter 6)
Degree of protection of housing	Degree of protection as per EN 60 529	IP 40
Protection class	Insulation class	as per EN 60730
	AC 24 V	III
	AC 230 V	II
	Auxiliary switches	II
Environmental conditions	Operation	EN 60721-3-3
	Climatic conditions	class 3K5
	Mounting location	interior, weather-protected
	Temperature	-32...+55 °C
	Humidity (non-condensing)	< 95% r. h.
	Transport	EN 60721-3-2
	Climatic conditions	class 2K2
	Temperature	-32...+70 °C
	Humidity (non-condensing)	< 95% r. h.
	Mechanical conditions	class 2M3
Standards and directives	Product safety	
	Automatic electrical controls for household and similar use	EN 60730-2-14 (type 1)
	Electromagnetic compatibility (EMC)	
	Immunity for all models	IEC/EN 61000-6-2
	Emissions for all models	IEC/EN 61000-6-3
	 Conformity to	
	EMV-directives	2004/108/EC
	Low voltage directives	2006/95/EC
	 C-Tick conformity to	
	Radio Interference Emission Standard	AS/NZS 61000-6-3
Dimensions	Actuator W x H x D (see "Dimensions")	81 x 212 x 63 mm
	Push rod (profile)	16 x 5 mm
Weight	without packaging	
	GEB13..2, 16..2	0.8 kg
	GEB33..2	0.9 kg

# 9 Diagrams

## 9.1 Internal diagrams

### Three-position control

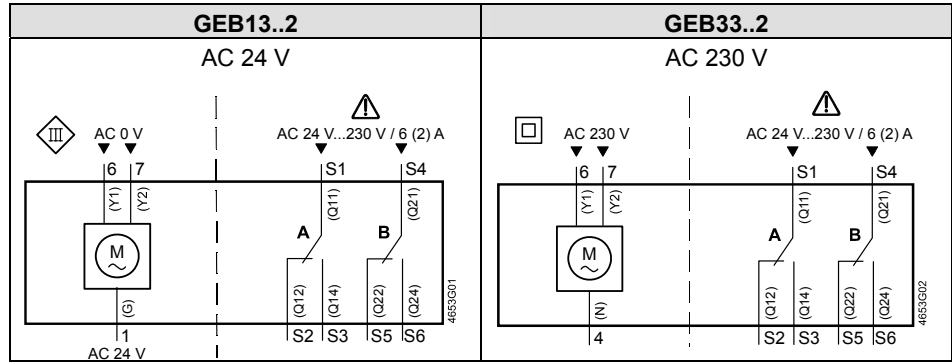

### Modulating control Y = DC 0...10 V, 2...10 V, 0...35 V

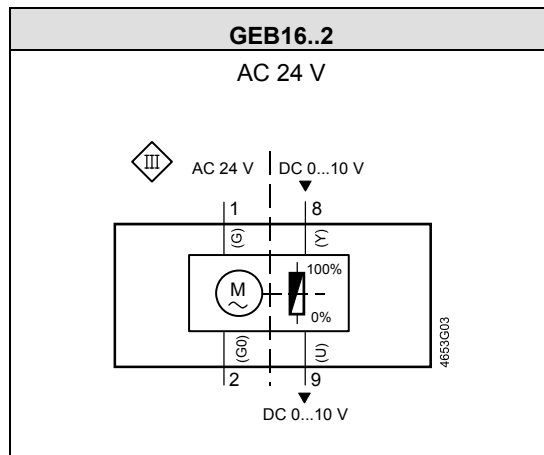

## 9.2 Cable labeling

All wires are color-coded and labeled.

Pin	Cable				Meaning
	Code	No.	Color	Abbreviation	
Actuators AC 24 V	G	1	red	RD	System potential AC 24 V
	G0	2	black	BK	System neutral
	Y1	6	purple	VT	Pos. signal AC 0 V, inward travel
	Y2	7	orange	OG	Pos. signal AC 0 V, outward travel
	Y	8	gray	GY	Pos. signal DC 0...10 V, 2...10 V, 0...35 V
Actuators AC 230 V	U	9	pink	PK	Position indication DC 0...10 V
	N	4	blue	BU	Neutral conductor
	Y1	6	black	BK	Pos. signal AC 230 V, inward travel
Auxiliary switches	Y2	7	white	WH	Pos. signal AC 230 V, outward travel
	Q11	S1	gray/red	GY RD	Switch A Input
	Q12	S2	gray/blue	GY BU	Switch A Normally closed contact
	Q14	S3	gray/pink	GY PK	Switch A Normally open contact
	Q21	S4	black/red	BK RD	Switch B Input
	Q22	S5	black/blue	BK BU	Switch B Normally closed contact
	Q24	S6	black/pink	BK PK	Switch B Normally open contact

## 9.3 Connection diagrams (three-position control)

### GEB13..2 AC 24 V (SELV/PELV)

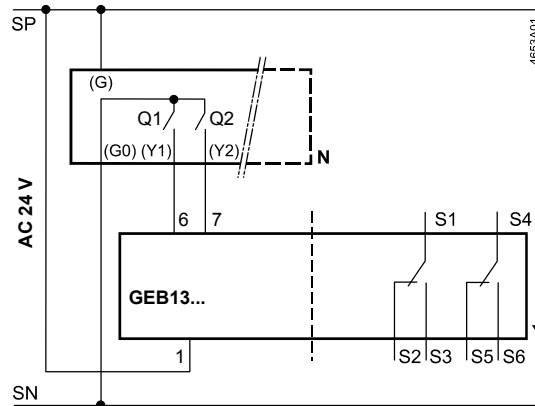

**N** Controller  
**Y** Actuator GEB13..2  
**SP** System potential AC 24 V  
**SN** System neutral  
**Q1, Q2** Controller contacts

### GEB33..2 AC 230 V

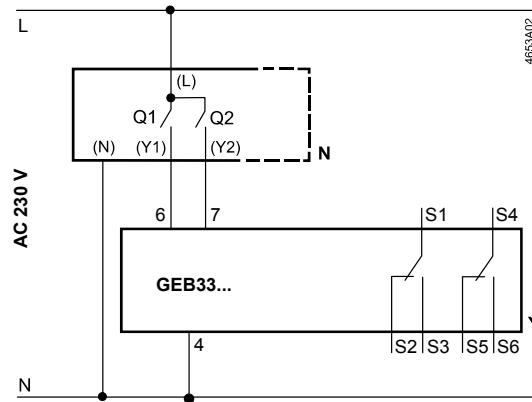

**N** Controller  
**Y** Actuator GEB33..2  
**L** System potential AC 230  
**V** System neutral  
**N** System neutral  
**Q1, Q2** Controller contacts

Operating states for  
actuators GEB13..2,  
GEB33..2

The table shows the actuator's operating state for both linear travel directions regardless of the position of the controller contacts Q1 and Q2.

Controller contacts		Operating state
Q1	Q2	
		Remains in position reached
		↓
		↑
		not permissible

4653T04en

## 9.4 Connection diagrams (modulating)

### 9.4.1 Typical application

The controller output is connected directly to the actuator input.

GEB16..2

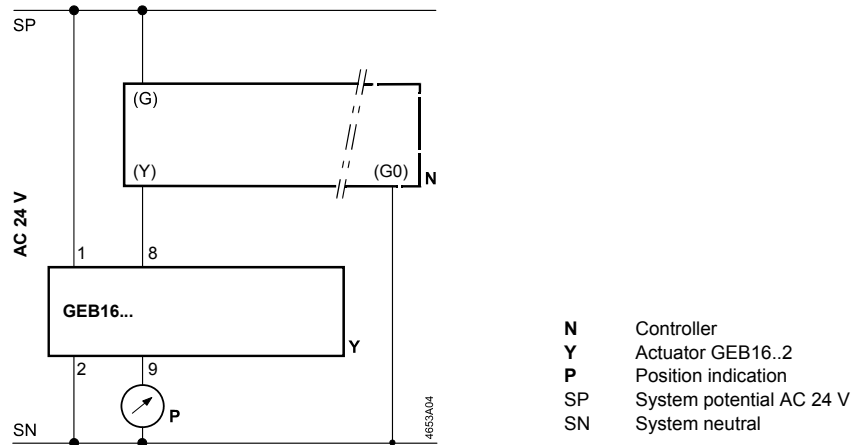

### 9.4.2 Special switchings for modulating control

The following connections enable different operating states of the actuator depending on the position of the changeover switch featuring switch contacts K1, K2, K3 (see table of operating states).

Modulating control, fully open, fully locked with GEB16..2

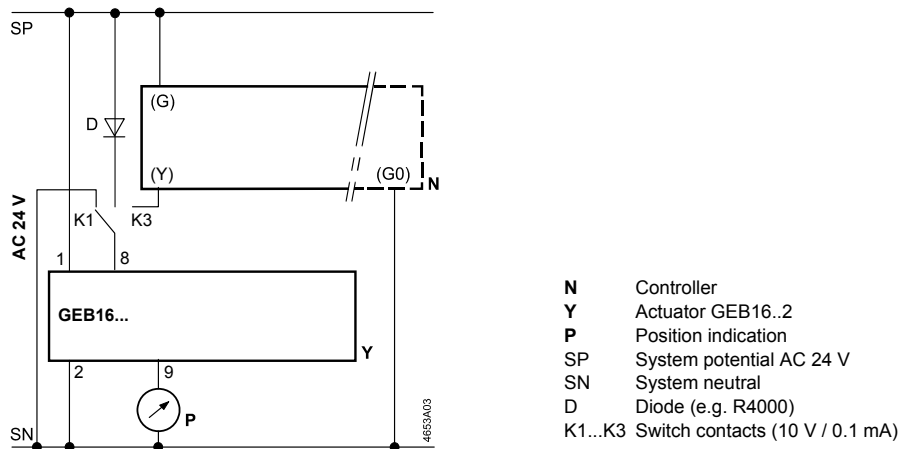

Operating states with GEB16..2

Switch contacts	Operating state	Linear direction	
K3	Modulating control		
K2	Fully open		
K1	Fully closed		
<b>DIL switch position</b>			

Note  
 GEB163.2

\*) Actuators with adjustable characteristic function: Full opening cannot be reached (dependent on  $U_0$ ,  $\Delta U$ ) in this position (switch contact K2).

# 10 Environmental compatibility and disposal

---

## General notes

This actuator was developed and manufactured by using environmentally-compatible materials and by complying with our environmental standards.

For disposal, please remember the following at the end of product life or on defects:

- The device consists of
  - Materials such as steel, aluminum die-cast, and zinc die-cast.Do not dispose as household garbage. This particularly applies to the circuit board.
- As a rule, dispose of all waste in an environmentally compatible manner and in accordance with environmental, recycling, and disposal techniques. **Adhere to all local and applicable laws.**
- The aim is to achieve maximum recyclability at the lowest possible pollution. To do this, note the various material and disposal notes printed on specific parts.

## Environmental declaration

The environmental declarations for these actuators contain detailed information on the materials and volumes used. Request a declaration at your local dealership.

# 11 Appendix

Chapter contents

This chapter contains:

- Linear actuator dimensions
- Referenced documents
- Feedback form

## 11.1 Dimensions

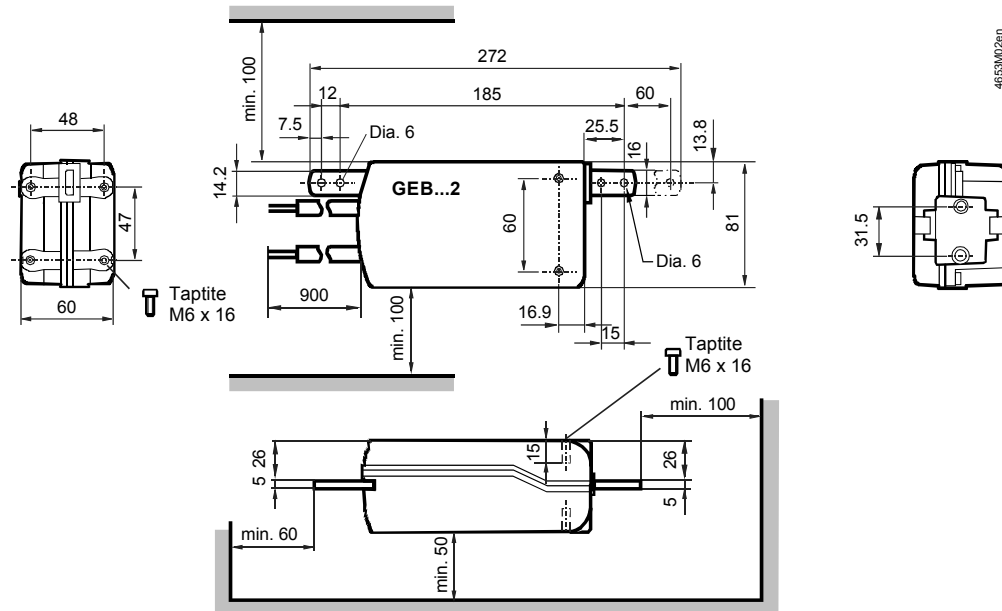

Dimensions in mm

## 11.2 Referenced documents

Purpose of this listing

The previous chapters contain all information relevant to safety and project-specific requirements, mounting, wiring, and commissioning of linear actuators.

Documents and standards

The following list contains all documents referenced by this document on basics:

- Data sheets (N....) with detailed specifications
- Basic documentation (Z....) with basics on air damper actuators
- Mounting instructions (M....), documents supplied with product

Note

The document and classification numbers listed in the table below match those of the database "STEP" on the company-internal Intranet.

Standards

All standards and directives relevant to engineering are also listed.

**Technical documentation**

Type series GEB...2

Document number (Classification no.)	Title/Description	Contents
CM2N4653en (N4653)	Actuators for air dampers, linear version (GEB...2: Two-pos., modulating).	Type overview, function and selection criteria.
CM2Z4653en (Z4653)	Technical basics, linear actuators, GEB...2 (this document).	Technical basics for engineering, mounting, wiring, and commissioning.
74 319 0110 0 (M4653)	Mounting instructions on GEB...2.	Instructions on mounting a linear actuator.

Accessories for type series GEB...2

CM2N4697en (N4697)	Accessories and spare parts for actuators GMA...1, GEB...	Overview, allocation to actuator type, and application.
74 319 0242 0 (M4653.1)	Linear/rotary set with mounting plate ASK72.3.	Mounting instructions and application examples.
74 319 0663 0 (M4614.8)	Weather Shield for actuators ASK75.6	Mounting instructions and application examples.

**Standards**

HD 384	Electrical installations in buildings
EN 61558	Safety of transformers, power supply units and similar equipment
EN 60730	Automatic electrical controls for household and similar use
IEC/EN 61000-1	Electromagnetic compatibility: Immunity
IEC/EN 61000-2	Electromagnetic compatibility: Immunity
IEC/EN 61000-3	Electromagnetic compatibility: Emissions
2004/108/EC	Directive on electromagnetic compatibility
2006/95/EC	Low voltage directive

Siemens Switzerland Ltd  
Infrastructure & Cities Sector  
Building Technologies Division  
Gubelstrasse 22  
6301 Zug  
Switzerland  
Tel. +41 41-724 24 24  
[www.siemens.com/sbt](http://www.siemens.com/sbt)

© 2005 - 2013 Siemens Switzerland Ltd.  
Subject to change