



Refrigerant Valves PN 40

MVF661...N

for industrial use in connection with ammonia (R717) and other refrigerants

- One valve type for expansion, hot-gas and suction throttle applications
- Hermetically sealed
- Selectable standard interface DC 0/2...10 V or DC 0/4...20 mA
- High resolution and control accuracy
- Precise positioning control and position feedback signal
- Short positioning time (< 1 second)
- Closed when deenergized
- Robust and maintenance-free
- DN 25 with k_{vs} values from 0.16 to 6.3 m³/h

Use

The MVL661...N refrigerant valve is designed for modulating control of refrigerant circuits including chillers and heat pumps. It is suitable for use in expansion, hot-gas and suction throttle applications. In addition to ammonia (R717), the valve can handle all standard refrigerants, noncorrosive gases / liquids and CO₂ (R744). It is not suited for use with inflammable refrigerants.

Type summary

The refrigeration capacity refers to applications using ammonia.

Refrigerant valves

Type reference	DN	k_{vs} [m ³ /h]	Q_0 E [kW]	Q_0 H [kW]	Q_0 D [kW]
MVF661.25-0.16N	25	0.16	95	10	2
MVF661.25-0.4N	25	0.40	245	26	5
MVF661.25-1.0N	25	1.0	610	64	12
MVF661.25-2.5N	25	2.5	1530	159	29
MVF661.25-6.3N	25	6.3	3850	402	74

Valve inserts

Type reference	DN	k_{vs} [m ³ /h]	Q_0 E [kW]	Q_0 H [kW]	Q_0 D [kW]
ASR0.16N	25	0.16	95	10	2
ASR0.4N	25	0.40	245	26	5
ASR1.0N	25	1.0	610	64	12
ASR2.5N	25	2.5	1530	159	29
ASR6.3N	25	6.3	3850	402	74

k_{vs} Nominal flow rate of refrigerant through the fully open valve (H_{100}) at a differential pressure of 100 kPa (1 bar) to VDI 2173

The k_{vs} values and the Q_0 refrigeration capacities can be reduced to 63 % if required, refer to page 4 « k_{vs} reduction »

Q_0 E Refrigeration capacity in expansion applications

Q_0 H Refrigeration capacity in hot-gas bypass applications

Q_0 D Refrigeration capacity in suction throttle applications and $\Delta p = 0.5$ bar

Q_0 With R717 at $t_0 = 0$ °C and $t_c = 40$ °C

The pressure drop across evaporator and condenser is assumed to be 0.3 bar each, and 1.6 bar upstream of the evaporator (e.g. spider).

The capacities specified are based on superheating by 6 K and subcooling by 2 K.

The refrigeration capacity for various refrigerants and operating conditions can be calculated for the 3 types of application using the tables at the end of this Data Sheet. For accurate valve sizing, the valve selection program "Refrigeration VASP" is recommended.

Order

Valve body and magnetic actuator form one integral unit and cannot be separated. When ordering, please give quantity, product name and type reference.

Example: 1 refrigerant valve MVF661.25-0.4N

Replacement electronics ASR61

Should the valve's electronics become faulty, the entire electronics housing is to be replaced by spare part ASR61, which is supplied complete with Mounting Instructions (74 319 0270 0).

Valve insert ASR...N



If plant is resized, or should excessive wear impact the valve's performance, a new valve insert ASR...N will restore the valve's characteristics to its original specifications. The valve insert is supplied complete with Mounting Instructions (74 319 0486 0).

Features and benefits

- 4 selectable standard signals for setpoint and measured value
- DIP switch to reduce the k_{vs} value to 63 % of the nominal value
- Potentiometer for adjustment of minimum stroke for suction throttle applications
- Automatic stroke calibration
- Forced control input for “Valve closed” or “Valve fully open”
- LED for indicating the operating state

The refrigerant valve can be driven by Siemens or third-party controllers that deliver a DC 0/2...10 V or DC 0/4...20 mA output signal.

For optimum control performance, we recommend a 4-wire connection between controller and valve. When operating on DC voltage, a 4-wire connection is **mandatory!** The valve stroke is proportional to the control signal.

Operator controls and indicators in the electronics housing

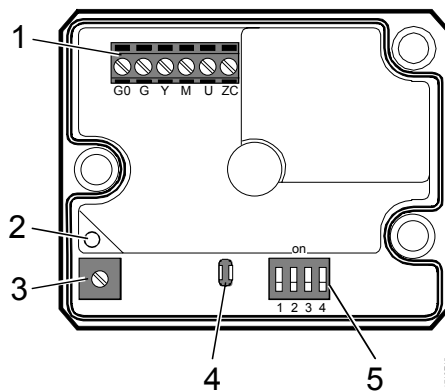

- 1 Connection terminals
- 2 LED for indication of operating state
- 3 Minimal stroke setting potentiometer Rv
- 4 Autocalibration
- 5 DIP switches for mode control

Override control

3 operating modes are possible with the forced control input (ZC):

- **No function:** ZC contact not wired; the valve stroke is determined by control signal Y
- **Forced control – valve fully open:** ZC connected directly to G (AC 24 V or DC 24)
- **Forced control – valve closed:** ZC connected directly to M or G0 respectively

Also refer to «Connection terminals» on page 8.

Signal priority

Of the possible input signals, override control signal ZC has the highest priority. If ZC is open, the valve stroke is determined by input Y and the potentiometer setting.

Minimum stroke setting

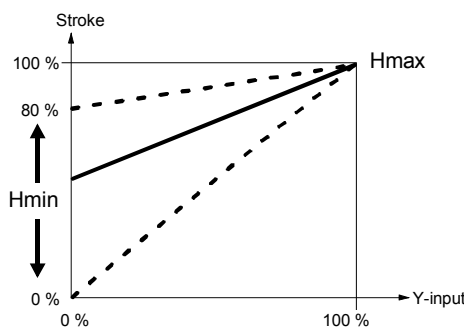

In the case of the suction throttle valve, it is essential that a minimum stroke limit be maintained to ensure compressor cooling and efficient oil return. This can be achieved with a reinjection valve, a bypass line across the valve, or a guaranteed minimum opening of the valve. The minimum stroke can be defined via the controller and control signal Y, or it can be set directly with potentiometer Rv.

The factory setting is zero (mechanical stop in counterclockwise direction, CCW). The minimum stroke can be set by turning the potentiometer clockwise to a maximum of 80 % k_{vs} .

Under no circumstances must potentiometer Rv be used to limit the stroke on expansion applications. It must be possible to close the valve fully.

k_{vs} reduction

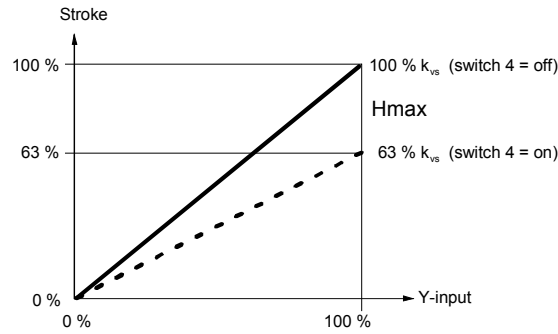

When k_{vs} reduction (DIP switch 4 in position on) the stroke will be limited to 63 % mechanical stroke. 63 % of full stroke then corresponds to an input / output signal of 10 V.

If, in addition, the stroke is limited to 80 %, for example, the minimum stroke will be 0.63 x 0.8 = 0.50 of full stroke.

Autocalibration

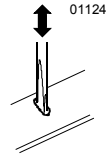

The printed circuit board of the MVF661...N has a slot to facilitate calibration. To make the calibration, insert a screwdriver in the slot so that the contacts inside are connected. As a result, the valve will be fully closed and then fully opened.

Calibration matches the electronics to the valve's mechanism.

MVF661...N refrigerant valves are supplied fully calibrated.

When is calibration required?

After replacement of the electronics (ASR61), when the red LED is lit, or when the valve (valve seat) is leaking.

Configuration of DIP switches

Switch	Value	off (factory setting)	on
1	Positioning signal Y	[V]	[mA]
2	Positioning range Y and U	0...10 V 0...20 mA	2...10 V 4...20 mA
3	Position feedback U	[V]	[mA]
4	Flow k _{vs}	100 % k _{vs}	63 % k _{vs}

Switch 2	Function of connection terminal			
	Y (positioning signal)		U (position feedback)	
	Switch 1		Switch 3	
	off	on	off	on
off	0...10 V	0...20 mA	0...10 V	0...20 mA
on	2...10 V	4...20 mA	2...10 V	4...20 mA

Indication of operating state

LED	State	Function	Action
LED green	Steady on	<ul style="list-style-type: none"> Operation 	Automatic mode; everything ok
	Flashing	<ul style="list-style-type: none"> Calibration in progress 	Wait until calibration is terminated (LED stops flashing)
LED red	Steady on	<ul style="list-style-type: none"> Calibration error Internal error 	Start stroke calibration again (short-circuit contacts via slot in PCB) Replace electronics
	Flashing	<ul style="list-style-type: none"> Mains fault 	Check mains power supply (e.g. outside the frequency or voltage range)
LED	Off	<ul style="list-style-type: none"> No power supply Faulty electronics 	Check mains power supply, check wiring Replace electronics

Depending on the application, it may be necessary to observe additional Installation Instructions and fit appropriate safety devices (e.g. pressurestats, full motor protection, etc.).

Warning  In order not to damage the seal inside the valve insert, the plant must be vented on the low-pressure side after the pressure test has been made (valve port AB), or the valve must be fully open during the pressure test and during venting (power supply connected and positioning signal at maximum or forced opening by G → ZC).

Expansion application

To prevent the formation of flash gas on expansion applications, the velocity of the refrigerant in the fluid pipe must not exceed 1 m/s. To assure this, the diameter of the fluid pipe must under certain circumstances be greater than the nominal size of the valve.

A filter / dryer must be mounted upstream of the expansion valve.

Recommendation

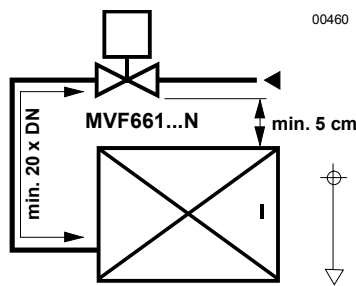

Laboratory measurements reveal that control performance improves when the refrigerant valve is installed so that it is higher than the evaporator (min. 50 mm). Allow a settling path of at least 0.5 m or 20 x DN between valve and distributor. This is a general recommendation for expansion valves.

The valve is not explosion-proof.

Sizing

For straightforward valve sizing, refer to the tables for the relevant application (from page 9).

For accurate valve sizing, we recommend to make use of the valve sizing software "Refrigeration VASP".

Notes

The refrigeration capacity Q_0 is calculated by multiplying the mass flow by the specific enthalpy differential found in the h, log p-chart for the relevant refrigerant. To help determine the refrigeration capacity more easily, a selection chart is provided for each application (page 9 and following). With direct or indirect hot-gas bypass applications, the enthalpy differential of Q_c (the condenser capacity) must also be taken into account when calculating the refrigeration capacity.

If the evaporating and / or condensing temperatures are between the values shown in the tables, the refrigeration capacity can be determined with reasonable accuracy by linear interpolation (refer to the application examples on page 9 and following).

At the operating conditions given in the tables, the permissible differential pressure Δp_{max} (25 bar) across the valve is within the admissible range for these valves.

If the evaporating temperature is raised by 1 K, the refrigeration capacity increases by about 3 %. If, by contrast, subcooling is increased by 1 K, the refrigeration capacity increases by about 1 to 2 % (this applies only to subcooling down to approximately 8 K).

Mounting notes

The valve should be mounted and commissioned by qualified staff. The same applies to the replacement electronics and the configuration of the controller (e.g. SAPHIR or PolyCool).

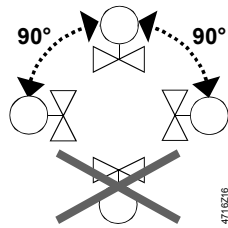

- The refrigerant valve can be mounted at any angle from upright to horizontal, but must not be suspended below the horizontal
- Pipework should be arranged such that the valve is not located at a low point in the plant where oil can collect
- The valve must not be fitted with the help of its bracket
- The valve body and the connected pipework should be lagged
- The actuator must not be lagged

The valve is supplied complete with Mounting Instructions 74 319 0468 0.

Maintenance

The refrigerant valve is maintenance-free.

Repair

If the valve's interior is subjected to great wear, the valve can be repaired by fitting an ASR...N replacement insert.

Disposal



The actuator contains electrical and electronic components and must not be disposed of together with domestic waste.

Legislation may demand special handling of certain components, or it may be sensible from an ecological point of view

Current local legislation must be observed.

Warranty

Application-specific technical data must be observed.

If specified limits are not observed, Siemens Building Technologies / HVAC Products will not assume any responsibility.

Technical data

Functional actuator data

• Power supply	Extra low-voltage only (SELV, PELV)		
• AC 24 V	Operating voltage	AC 24 V \pm 20 %	
	Frequency	45...65 Hz	
	Typical power consumption	P_{med}	12 W
		Standby	< 1 W (valve closed)
	Rated apparent power S_{NA}	22 VA (for selecting the transformer)	
Required fuse	1.6...4 A (slow)		
• DC 24 V	Operating voltage	DC 20...30 V	
	Current draw	0.5 A / 2 A (max.)	
	• Input	Control signal Y	DC 0/2...10 V or DC 0/4...20 mA
Impedance DC 0/2 ... 10 V		100 k Ω // 5nF	
		DC 0/4 ... 20 mA	240 Ω // 5nF
• Output	Forced control		
	Input impedance	22 k Ω	
	Close valve (ZC connected to G0)	< AC 1 V; < DC 0.8 V	
	Open valve (ZC connected to G)	> AC 6 V; > DC 5 V	
	No function (ZC not wired)	Positioning signal Y active	
Position feedback signal	Voltage	DC 0/2...10 V; load resistance \geq 500 Ω	
	Current	DC 0/4...20 mA; load resistance \leq 500 Ω	

Functional valve data	PN class	PN 40 to EN 1333
	Perm. pressure	4.0 Mpa (40 bar) ¹⁾
	Max. differential pressure Δp_{\max}	2.5 Mpa (25 bar)
	Leakage rate (internally across seat)	max. 0.002 % k_{vs} or max. 1 NI/h gas at $\Delta p = 4$ bar (must not be used for safety shutoff functions)
	Permissible media	ammonia (R717), CO ₂ (R744) and all standard refrigerants (HFKW, HFCKW, FCKW); not suited for use with inflammable refrigerants
	Medium temperature	- 40...120 °C; max. 140 °C for 10 min
	External seal	hermetically sealed!
	Valve characteristic (stroke, k_v)	linear (to VDI / VDE 2173)
	Stroke resolution $\frac{\Delta H}{H_{100}}$	1 : 1000 (H = stroke)
	Mode of operation	modulating
	Position when deenergized	closed
	Mounting position ²⁾	upright to horizontal
	Positioning time	< 1 s
	Materials	Valve body
Seat / piston		CrNi steel
Sealing disk / O-rings		PTFE / CR
Pipe connections	Flanges	as per EN 1092-1 DIN 2635 form F DIN 2512
Electrical connections	Cable entry glands	3 x 20.5 mm dia. (for M20)
	Min. cross-sectional area of cable	0.75 mm ²
	Max. cable length between transformer / power supply and valve	65 m with 1.5 mm ² cable (copper) 110 m with 2.5 mm ² cable (copper) 160 m with 4.0 mm ² cable (copper)
Dimensions and weight	Dimensions	refer to «Dimensions»
	Weight	5.750 kg
Norms and standards	Protection standard	IP 65 to IEC 529
	Conformity	meets the requirements for CE marking UL listed for UL 873 C-UL certified to Canadian Standard C22.2 No. 24 C-Tick N 474 PED 97/23/EC: pressure bearing equipment Art. 1, Par. 2.1.4 / Art. 3, Par. 3
	AC + DC: immunity	Industrial IEC 61000-6-2 ³⁾
	AC: Emissions	Residential IEC 61000-6-3
	DC: Emissions	CISPR 22, class B
	HF interference immunity	IEC 1000-4-3; IEC 1000-4-6 (10 V/m)
	HF interference emission	EN 55022, CISPR 22, class B
	Vibration ⁴⁾	IEC 68-2-6 5 g acceleration, 10...150 Hz, 2.5 h (5 g horizontal, max. 2 g upright)

¹⁾ On the basis of DIN 3230-3 tested with 1.5 x operating pressure (60 bar)

²⁾ At 45 °C < T_{amb} < 55 °C and 80 °C < T_{med} < 120 °C the valve must be installed on its side to avoid shortening the service life of the valve electronics

³⁾ Transformer 160 VA (e.g. Siemens 4AM 3842-4TN00-0EA0)

⁴⁾ In conjunction with severely vibrating plant, use only highly flexible stranded wires

General environmental conditions

	Operation IEC 721-3-3	Transport IEC 721-3-2	Storage IEC 721-3-1
Climatic conditions	Class 3K6	Class 2K3	Class 1K3
Temperature	-25...55 °C	-25...70 °C	-5...45 °C
Humidity	10...100 % r. h.	< 95 % r. h.	5...95 % r. h.

Connection terminals

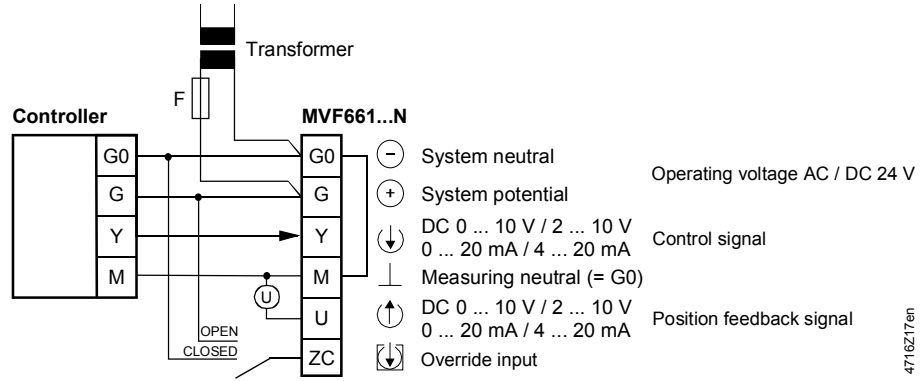

Dimensions

Dimensions in mm

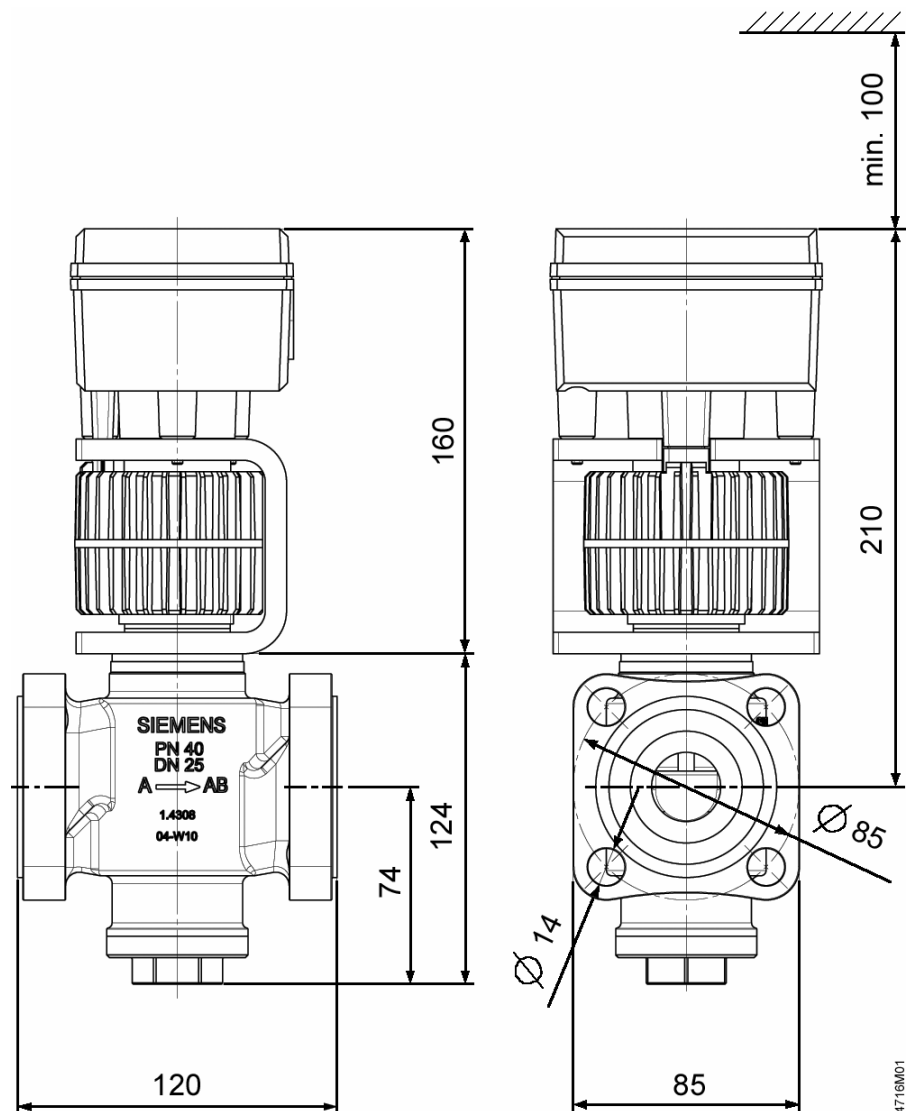

Valve sizing with correction factor

The applications and tables on the following pages are designed for help with selecting the valves. To select the correct valve, the following data is required:

- **Application**
 - Expansion (starting on page 9)
 - Hot-gas (starting on page 12)
 - Suction throttle (starting on page 14)
- **Refrigerant type**
- **Evaporating temperature t_o [°C]**
- **Condensing temperature t_c [°C]**
- **Refrigeration capacity Q_o [kW]**

To calculate the nominal capacity, use the following formula:

- $k_{vs} [\text{m}^3/\text{h}] = Q_o [\text{kW}] / K... * K...$
 - for expansion = KE
 - for hot-gas = KH
 - for suction throttle = KS
- The theoretical k_v value for the nominal refrigeration capacity of the plant should not be less than 50 % of the k_{vs} value of the selected valve
- For accurate valve sizing, the valve selection program «Refrigeration VASP» is recommended

The application examples on the following pages deal with the principles only. They do not include installation-specific details such as safety elements, refrigerant collectors, etc.

Use of the MVF661...N as an expansion valve

- Typical control range 20...100 %.
- Increased capacity through better use of the evaporator
- The use of 2 or more compressors or compressor stages significantly increases efficiency with low loads
- Especially suitable for fluctuating condensing and evaporating pressures

Capacity optimization

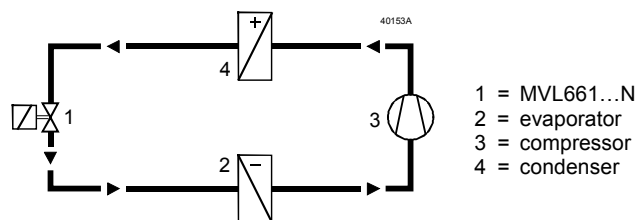

Electronic superheat control is achieved by using additional control equipment (e.g. PolyCool).

Application example

Refrigerant R407C; $Q_o = 205 \text{ kW}$; $t_o = -5 \text{ °C}$; $t_c = 35 \text{ °C}$
The correct k_{vs} value for the MVL661...N valve needs to be determined.

The important section of table KE for R407C (see page 12) is the area around the working point. The correction factor KE relevant to the working point should be determined by linear interpolation from the 4 guide values.

Note on interpolation

In practice, the KE, KH or KS value can be estimated because the theoretical k_{vs} -value ascertained will be rounded off by up to 30 % to 1 of the 10 available k_{vs} -values. So you can proceed directly with Step 4.

- Step 1: For $t_c = 35$, calculate the value for $t_o = -10$ between values 20 and 40 in the table; result: **574**
- Step 2: For $t_c = 35$, calculate the value for $t_o = 0$ between values 20 and 40 in the table; result: **553**
- Step 3: For $t_o = -5$, calculate the value for $t_c = 35$ between correction factors 574 and 553; calculated in steps 1 and 2; result: **450**
- Step 4: Calculate the theoretical k_{vs} value; result: **0.46 m³/h**
- Step 5: Select the valve; the valve closest to the theoretical k_{vs} value is the **MVF661.25-0.4N**
- Step 6: Check that the theoretical k_{vs} value is not less than 50 % of the nominal k_{vs} value

KE-R407C	$t_o = -10\text{ °C}$	$t_o = 0\text{ °C}$
$t_c = 20\text{ °C}$	481	376
$t_c = 35\text{ °C}$	574	553
$t_c = 40\text{ °C}$	605	612

Interpolation at	$t_c = 35\text{ °C}$
$481 + [(605 - 481) \times (35 - 20) / (40 - 20)]$	574
$376 + [(612 - 376) \times (35 - 20) / (40 - 20)]$	553

Interpolation at	$t_o = -5\text{ °C}$
$574 + [(553 - 574) \times (-5 - 0) / (-10 - 0)]$	450

k_{vs} theoretical = $205\text{ kW} / 450 = 0.46\text{ m}^3/\text{h}$

Valve MVF661.25-0.4N is suitable, since: $0.46\text{ m}^3/\text{h} / 0.4\text{ m}^3/\text{h} \times 100\% = 115\% (> 50\%)$

Capacity control

- a) Refrigerant valve MVF661...N for capacity control of a dry expansion evaporator. Suction pressure and temperature are monitored with a mechanical capacity controller and reinjection valve.
- Typical control range 0...100 %
 - Energy-efficient operation with low loads
 - Ideal control of temperature and dehumidification

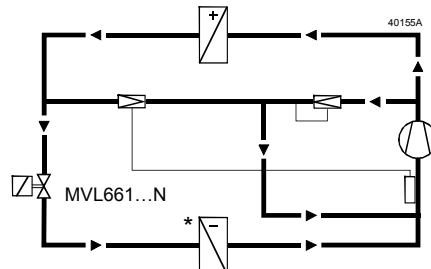

- b) Refrigerant valve MVF661...N for capacity control of a chiller.
- Typical control range 10...100 %
 - Energy-efficient operation with low loads
 - Allows wide adjustment of condensing and evaporating temperatures
 - Ideal for use with plate heat exchangers
 - Very high degree of frost protection

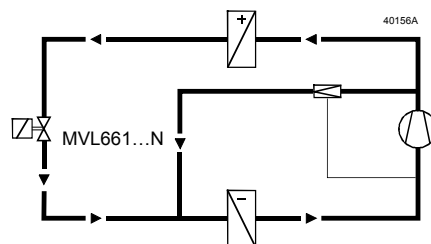

Note A larger valve may be required for low-load operation than is needed for full load conditions. To ensure that the selected valve will not be too small for low loads, sizing should take account of both possibilities.

Correction table KE

Expansion valve

$t_c \setminus t_o$	R717					
	-40	-30	-20	-10	0	10
00	324	265	124			
20	481	488	494	481	376	124
40	581	590	598	605	612	618
60	662	673	683	693	701	708

$t_c \setminus t_o$	R22					
	-40	-30	-20	-10	0	10
00	82	68	37			
20	101	104	107	105	81	18
40	108	111	114	118	120	123
60	104	108	112	116	119	122

$t_c \setminus t_o$	R744					
	-40	-30	-20	-10	0	10
-20	226	149				
00	262	264	241	166		
20	245	247	247	246	213	

$t_c \setminus t_o$	R134a					
	-40	-30	-20	-10	0	10
00	27					
20	71	74	77	66	43	
40	74	78	81	85	89	92
60	67	72	76	81	85	89

$t_c \setminus t_o$	R402A					
	-40	-30	-20	-10	0	10
00	73	69	50			
20	77	81	85	88	74	35
40	71	75	80	84	88	91
60	50	55	60	65	69	74

$t_c \setminus t_o$	R401A					
	-40	-30	-20	-10	0	10
00	31					
20	80	83	85	72	46	
40	87	90	94	97	101	102
60	85	89	94	98	102	106

$t_c \setminus t_o$	R407A					
	-40	-30	-20	-10	0	10
00	79	67	40			
20	91	95	98	102	82	30
40	89	94	98	102	106	110
60	72	77	82	87	92	96

$t_c \setminus t_o$	R404A					
	-40	-30	-20	-10	0	10
00	69	63	44			
20	70	74	78	81	68	30
40	61	65	70	74	78	81
60	36	41	46	51	55	59

$t_c \setminus t_o$	R407C					
	-40	-30	-20	-10	0	10
00	79	65	31			
20	98	101	105	108	85	21
40	100	104	109	113	117	121
60	87	93	98	103	108	113

$t_c \setminus t_o$	R407B					
	-40	-30	-20	-10	0	10
00	72	66	45			
20	77	80	84	88	75	34
40	69	74	78	83	87	91
60	46	51	56	61	66	70

$t_c \setminus t_o$	R507					
	-40	-30	-20	-10	0	10
00	72	66	47			
20	78	81	83	86	71	33
40	74	78	81	84	87	90
60	53	57	61	64	68	71

$t_c \setminus t_o$	R410A					
	-40	-30	-20	-10	0	10
00	116	117	91	12		
20	125	130	133	137	120	69
40	119	124	129	133	137	140
60	90	96	101	106	110	114

- With superheat = 6 K
- Δp condenser = 0.3 bar
- With subcooling = 2 K
- Δp evaporator = 0.3 bar
- Δp upstream of evaporator = 1.6 bar

The control valve throttles the capacity of a compressor stage. The hot gas passes directly to the evaporator, thus permitting capacity control in the range from 100 % down to approximately 0 %.

Indirect hot-gas bypass application

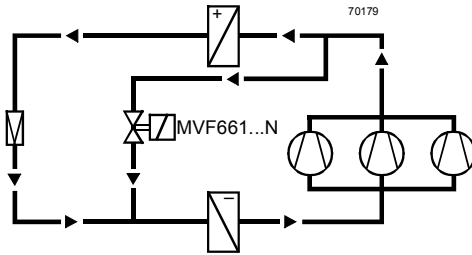

Suitable for use in large refrigeration systems in air conditioning plant, to prevent unacceptable temperature fluctuations between the compressor stages.

Application example

With low loads, the evaporating and condensing pressures can fluctuate depending on the type of pressure control. In such cases, evaporating pressure increases and condensing pressure decreases. Due to the reduction in differential pressure across the fully open valve, the volumetric flow rate will drop – the valve is undersized. This is why the effective pressures must be taken into account when sizing the valve for low loads.

Refrigerant R507; 3 compressor stages; $Q_0 = 75 \text{ kW}$; $t_0 = 4 \text{ °C}$; $t_c = 40 \text{ °C}$
 Part load Q_0 per stage = 28 kW ; $t_0 = 4 \text{ °C}$; $t_c = 23 \text{ °C}$

KH-R507	$t_0 = 0 \text{ °C}$	$t_0 = 10 \text{ °C}$
$t_c = 2 \text{ °C}$	14.4	9.0
$t_c = 23 \text{ °C}$	15.6	11.0
$t_c = 40 \text{ °C}$	22.4	22.0

Interpolation at	$t_c = 23 \text{ °C}$
$14.4 + [(22.4 - 14.4) \times (23 - 20) / (40 - 20)]$	15.6
$9.0 + [(22.0 - 9.0) \times (23 - 20) / (40 - 20)]$	11.0

Interpolation at	$t_0 = 4 \text{ °C}$
$15.6 + [(11.0 - 15.6) \times (4 - 0) / (10 - 0)]$	13.8

$k_{vs} \text{ theoretical} = 28 \text{ kW} / 13.8 = 2.03 \text{ m}^3/\text{h}$

Valve MVF661.25-2.5N is suitable, since: $2.03 \text{ m}^3/\text{h} / 2.5 \text{ m}^3/\text{h} \times 100 \% = 81 \% (> 50 \%)$

Direct hot-gas bypass application

The control valve throttles the capacity of one compressor stage. The gas is fed to the suction side of the compressor and then cooled using a reinjection valve. Capacity control ranges from 100 % down to approximately 10 %.

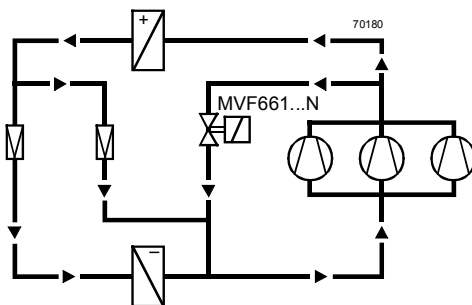

Suitable for large refrigeration systems on air conditioning applications with several compressors or compressor stages, and where the evaporator and compressor are some distance apart (attention must be paid to the oil return).

Correction table KH

Hot-gas valve

$t_c \setminus t_o$	R717					
	-40	-30	-20	-10	0	10
00	20	19	14			
20	38	38	38	38	35	19
40	67	66	65	64	64	63
60	110	107	105	103	102	100

$t_c \setminus t_o$	R22					
	-40	-30	-20	-10	0	10
00	8.9	8.4	6.3			
20	15.3	15.1	14.8	14.6	13.2	6.5
40	24.2	23.7	23.2	22.8	22.4	22.1
60	35.7	34.7	33.8	33.0	32.3	31.7

$t_c \setminus t_o$	R744					
	-40	-30	-20	-10	0	10
-20	38.1	30.5				
00	60.9	59.8	58.1	47.1		
20	87.3	84.9	82.5	80.2	76.1	

$t_c \setminus t_o$	R134a					
	-40	-30	-20	-10	0	10
00	4.5					
20	9.8	9.6	9.5	9.2	7.4	
40	15.9	15.6	15.3	15.1	14.9	14.7
60	23.8	23.2	22.7	22.3	21.9	21.6

$t_c \setminus t_o$	R402A					
	-40	-30	-20	-10	0	10
00	9.7	9.5	8.3			
20	15.9	15.7	15.4	15.2	14.5	9.3
40	23.7	23.2	22.7	22.4	22.0	21.7
60	31.5	30.7	29.9	29.2	28.7	28.1

$t_c \setminus t_o$	R401A					
	-40	-30	-20	-10	0	10
00	4.7					
20	10.2	10.0	9.9	9.5	7.6	
40	16.9	16.6	16.2	16.0	15.8	15.6
60	25.9	25.2	24.6	24.1	23.7	23.3

$t_c \setminus t_o$	R407A					
	-40	-30	-20	-10	0	10
00	8.9	8.6	6.7			
20	15.7	15.4	15.2	15.0	14.1	8.0
40	24.9	24.4	23.9	23.5	23.1	22.8
60	35.9	34.9	34.0	33.2	32.6	32.0

$t_c \setminus t_o$	R404A					
	-40	-30	-20	-10	0	10
00	9.4	9.2	7.8			
20	15.2	15.0	14.8	14.6	13.9	8.6
40	22.3	21.8	21.5	21.1	20.9	20.6
60	28.8	28.0	27.4	26.8	26.4	25.9

$t_c \setminus t_o$	R407C					
	-40	-30	-20	-10	0	10
00	8.6	8.1	5.9			
20	15.3	15.0	14.8	14.6	13.6	7.0
40	24.7	24.2	23.7	23.3	22.9	22.6
60	36.3	35.3	34.4	33.6	33.0	32.4

$t_c \setminus t_o$	R407B					
	-40	-30	-20	-10	0	10
00	9.0	8.8	7.4			
20	15.3	15.1	14.8	14.7	14.0	8.8
40	23.3	22.8	22.4	22.0	21.7	21.5
60	31.6	30.7	30.0	29.3	28.8	28.3

$t_c \setminus t_o$	R507					
	-40	-30	-20	-10	0	10
00	9.8	9.5	8.1			
20	16.1	15.8	15.5	15.3	14.4	9.0
40	24.5	23.8	23.3	22.8	22.4	22.0
60	33.1	31.8	30.7	29.8	29.0	28.3

$t_c \setminus t_o$	R410A					
	-40	-30	-20	-10	0	10
00	14.5	14.3	13.2	6.2		
20	24.2	23.7	23.3	23.0	22.1	15.9
40	36.8	35.9	35.1	34.4	33.7	33.1
60	50.0	48.5	47.2	46.0	44.9	43.8

- With superheat = 6 K
- Δp condenser = 0.3 bar
- With subcooling = 2 K
- Δp evaporator = 0.3 bar
- Δp upstream of evaporator = 1.6 bar

Use of the MVF661...N as a suction throttle valve

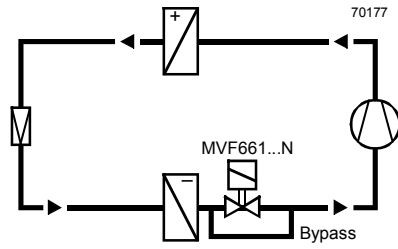

Typical control range 50...100 %.
 Minimum stroke limit control:
 To ensure optimum cooling of the compressor, either a capacity controller must be provided for the compressor, or a minimum stroke must be set via the valve electronics.

The minimum stroke can be limited to a maximum of 80 %. At zero load, the minimum stroke must be sufficient to ensure that the minimum gas velocity in the suction line is > 0.7 m/s and that the compressor is adequately cooled.

As the control valve closes, the evaporating temperature rises and the air-cooling effect decreases continuously. The electronic control system provides demand-based cooling without unwanted dehumidification and costly retreatment of the air.

The pressure at the compressor inlet falls and the power consumption of the compressor is reduced. The energy savings to be anticipated with low loads can be determined from the compressor selection chart (power consumption at minimum permissible suction pressure). Compressor energy savings of up to 40 % can be achieved.

The recommended differential pressure Δp_{v100} across the fully open control valve is between $0.15 < \Delta p_{v100} < 0.5$ bar.

Application example

Refrigerant R134A; $Q_0 = 9.5$ kW; $t_0 = 4$ °C; $t_c = 40$ °C;
 Differential pressure across MVF661..N: $\Delta p_{v100} = 0.25$ bar

In this application example, t_0 , t_c and Δp_{v100} are to be interpolated.

KS-R134a	$t_0 = 0$ °C	$t_0 = 10$ °C	Interpolation at	$t_0 = 4$ °C
0.15 / 20	2.2	2.7	$2.2 + [(2.7 - 2.2) \times (4 - 0) / (10 - 0)]$	2.4
0.15 / 50	1.7	2.1	$1.7 + [(2.1 - 1.7) \times (4 - 0) / (10 - 0)]$	1.9
0.45 / 20	3.6	4.5	$3.6 + [(4.5 - 3.6) \times (4 - 0) / (10 - 0)]$	4.0
0.45 / 50	2.7	3.4	$2.7 + [(3.4 - 2.7) \times (4 - 0) / (10 - 0)]$	3.0

$t_0 = 4$ °C	$t_c = 20$ °C	$t_c = 50$ °C	Interpolation at	$t_c = 40$ °C
$\Delta p_{v100} 0.15$	2.4	1.9	$2.4 + [(1.9 - 2.4) \times (40 - 20) / (50 - 20)]$	2.1
$\Delta p_{v100} 0.45$	4.0	3.0	$4.0 + [(3.0 - 4.0) \times (40 - 20) / (50 - 20)]$	3.3

$t_c = 40$ °C	$\Delta p_{v100} 0.15$	$\Delta p_{v100} 0.45$	Interpolation at	$\Delta p_{v100} 0.25$
	2.1	3.3	$2.1 + [(3.3 - 2.1) \times (0.25 - 0.15) / (0.45 - 0.15)]$	2.5

k_{vs} theoretical = 9.5 kW / $2.5 = 3.8$ m³/h

Valve MVF661.25-6.3N is suitable, since 3.8 m³/h / 6.3 m³/h x 100 % = 60 % (> 50 %)

It is recommended that the k_{vs} value be set to 63 % = 4 m³/h

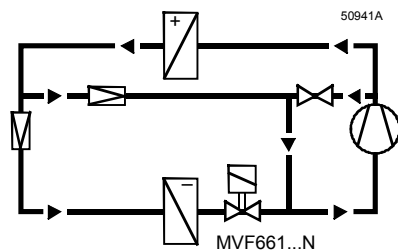

Typical control range 10...100 %.
 The capacity controller ensures that the compressor is adequately cooled, making it unnecessary to set a minimum stroke in the refrigerant valve.

Correction table KS
Suction throttle valve

t_c	R717					
	$\Delta p_{v100} \setminus t_o$	-40	-30	-20	-10	0
0.15 / 20	2.7	3.7	4.8	6.0	7.3	8.8
0.15 / 50	2.3	3.2	4.2	5.2	6.4	7.8
0.45 / 20	3.2	5.2	7.4	9.7	12.1	14.8
0.45 / 50	2.8	4.6	6.5	8.5	10.7	13.1

t_c	R22					
	$\Delta p_{v100} \setminus t_o$	-40	-30	-20	-10	0
0.15 / 20	1.2	1.5	1.9	2.4	2.9	3.4
0.15 / 50	0.9	1.2	1.5	1.9	2.3	2.7
0.45 / 20	1.5	2.3	3.0	3.9	4.8	5.7
0.45 / 50	1.2	1.8	2.4	3.0	3.8	4.6

t_c	R152A					
	$\Delta p_{v100} \setminus t_o$	-40	-30	-20	-10	0
0.15 / 20	0.9	1.3	1.7	2.2	2.7	3.3
0.15 / 50	0.7	1.0	1.4	1.7	2.2	2.7
0.45 / 20	1.0	1.5	2.4	3.3	4.3	5.3
0.45 / 50	0.7	1.2	1.9	2.6	3.5	4.4

t_c	R134a					
	$\Delta p_{v100} \setminus t_o$	-40	-30	-20	-10	0
0.15 / 20	0.7	1.0	1.4	1.8	2.2	2.7
0.15 / 50	0.5	0.7	1.0	1.3	1.7	2.1
0.45 / 20	0.7	1.2	1.9	2.7	3.6	4.5
0.45 / 50	0.5	0.9	1.4	2.0	2.7	3.4

t_c	R402A					
	$\Delta p_{v100} \setminus t_o$	-40	-30	-20	-10	0
0.15 / 20	1.1	1.4	1.8	2.2	2.7	3.3
0.15 / 50	0.7	0.9	1.2	1.5	1.8	2.3
0.45 / 20	1.5	2.2	2.9	3.7	4.6	5.6
0.45 / 50	0.9	1.4	1.9	2.4	3.1	3.8

t_c	R401A					
	$\Delta p_{v100} \setminus t_o$	-40	-30	-20	-10	0
0.15 / 20	0.8	1.1	1.5	1.9	2.3	2.9
0.15 / 50	0.6	0.8	1.1	1.5	1.8	2.3
0.45 / 20	0.8	1.3	2.1	2.9	3.7	4.7
0.45 / 50	0.6	1.0	1.6	2.3	3.0	3.7

t_c	R407A					
	$\Delta p_{v100} \setminus t_o$	-40	-30	-20	-10	0
0.15 / 20	1.0	1.4	1.8	2.3	2.9	3.5
0.15 / 50	0.7	1.0	1.3	1.6	2.1	2.6
0.45 / 20	1.3	2.0	2.9	3.8	4.7	5.9
0.45 / 50	0.9	1.4	2.0	2.7	3.4	4.3

t_c	R404A					
	$\Delta p_{v100} \setminus t_o$	-40	-30	-20	-10	0
0.15 / 20	1.0	1.3	1.7	2.2	2.7	3.3
0.15 / 50	0.6	0.8	1.1	1.4	1.7	2.1
0.45 / 20	1.4	2.1	2.8	3.6	4.5	5.5
0.45 / 50	0.8	1.2	1.7	2.3	2.9	3.6

t_c	R407C					
	$\Delta p_{v100} \setminus t_o$	-40	-30	-20	-10	0
0.15 / 20	1.0	1.4	1.8	2.3	2.9	3.5
0.15 / 50	0.7	1.0	1.3	1.7	2.1	2.6
0.45 / 20	1.3	2.0	2.8	3.8	4.8	5.9
0.45 / 50	0.9	1.4	2.1	2.8	3.5	4.4

t_c	R407B					
	$\Delta p_{v100} \setminus t_o$	-40	-30	-20	-10	0
0.15 / 20	1.0	1.3	1.7	2.2	2.7	3.3
0.15 / 50	0.6	0.8	1.1	1.4	1.8	2.2
0.45 / 20	1.3	2.0	2.7	3.5	4.5	5.5
0.45 / 50	0.8	1.2	1.7	2.3	3.0	3.8

t_c	R507					
	$\Delta p_{v100} \setminus t_o$	-40	-30	-20	-10	0
0.15 / 20	1.1	1.4	1.8	2.3	2.7	3.3
0.15 / 50	0.7	1.0	1.3	1.6	1.9	2.4
0.45 / 20	1.6	2.2	2.9	3.7	4.6	5.6
0.45 / 50	1.1	1.5	2.0	2.6	3.2	4.0

t_c	R410A					
	$\Delta p_{v100} \setminus t_o$	-40	-30	-20	-10	0
0.15 / 20	1.5	2.0	2.5	3.0	3.6	4.4
0.15 / 50	1.0	1.3	1.7	2.1	2.6	3.1
0.45 / 20	2.3	3.1	4.0	5.0	6.1	7.4
0.45 / 50	1.6	2.1	2.8	3.5	4.4	5.3

- With superheat = 6 K
- Δp condenser = 0.3 bar
- With subcooling = 2 K
- Δp evaporator = 0.3 bar
- Δp upstream of evaporator = 1.6 bar

