

SIEMENS



Variable Speed Drive

G120P

Mounting

Commissioning

Table of Contents

1	Safety	5
1.1	Typographical conventions	5
1.2	Safety	5
1.3	Disclaimer of liability	7
2	Mounting and installation	8
2.1	Dimension drawings of the PM230	8
2.2	Structure of the Control Unit	8
2.3	Terminal strips in the Control Unit.....	9
2.4	Motor cable lengths and cross-sections.....	9
2.4.1	Cable specifications for conformity with EMC requirements	9
2.4.2	Cable cross-sections	10
2.5	Wiring sequence for IP55	10
2.6	Line and motor connections.....	12
2.6.1	IP55.....	12
2.6.2	IP20.....	14
2.7	EMC directives	15
2.7.1	IP55.....	16
2.7.2	IP20.....	18
3	Commissioning	20
3.1	Operator panels.....	20
3.1.1	IOP	20
3.1.2	BOP-2	21
3.1.3	Saving drive data on a ROM.....	22
3.2	Preparing for commissioning	23
3.3	Basic factory settings.....	23
3.4	Basic commissioning with the wizard.....	24
3.4.1	IOP	25
3.4.2	BOP-2	25
3.5	Additional settings	26
3.5.1	Resetting to factory settings	26
3.5.2	Setting the ramp-function generator	27
3.5.3	Setting the PID controller.....	28
3.5.4	Transferring the license terms	28
3.6	Additional important parameters	29
3.7	Communication.....	30
3.7.1	RS485 interface.....	31
3.7.2	USS protocol	32
3.7.3	Modbus RTU protocol.....	33
3.7.4	BACnet MS/TP	33
3.7.5	P1 FLN	35
3.8	Data backup on a memory card.....	36
4	Application examples	37
4.1	Universal application	37

4.2	Pump pressure control.....	38
4.3	Pressure controlled supply fan + ESM fixed speed.....	39
4.4	Cooling tower fan (LG-Ni1000) + hibernation.....	40
4.5	Cooling tower fan (active sensor) + hibernation.....	41
4.6	Stairwell pressurization (ESM).....	42
4.7	Fixed setpoints	43
4.8	CO2 sensor, 2 PID setpoints	44
4.9	Temperature-dependent pressure setpoint.....	45
5	Service and maintenance	46
5.1	Service life of the fan	46
6	Fault rectification	47
6.1	Restart after a crash	47
6.2	Displayed operating states	47
6.3	Alarms and faults.....	48
6.4	Hardware diagnostics	53
6.4.1	Tests without a power supply	53
6.4.2	Power test	55
6.4.3	Function test.....	56
7	Appendix	58
7.1	Commissioning report.....	58
7.2	Available documentation.....	58

1 Safety

1.1 Typographical conventions

The safety instructions in this document contain the following elements:

- **Symbol** to indicate the nature of the danger
- **Signal word** to indicate the severity of the danger
- **Type and source** of the danger
- **Consequences** of failing to heed the danger
- **Measures** to avoid the danger

Symbols to indicate the nature of the danger

The following symbols are used in the document:



Warning of dangerous voltages



General warning



Warning - hand injuries

Signal word to indicate the severity of the danger



The following signal words (according to ANSI Z535) are used in the document:

Signal word	Severity of the danger
DANGER!	Characterizes an immediate danger . If the danger is ignored, death or serious injuries will result.
WARNING!	Characterizes a possible danger . If the danger is ignored, death or serious injuries may result.
CAUTION!	Characterizes a possible danger . If the danger is ignored, minor or slight injuries may result.
NOTE!	Characterizes a possible hazardous situation. If this is ignored, damage may occur to the plant or to the area around it.

1.2 Safety

General warnings, precautionary measures and hazard instructions which apply when working with the device are collated in this section. Safety information which only applies to certain tasks is listed at the start of every section or is repeated or added at critical points within these sections.

1. Please read this information carefully.
2. Pay attention to all the warning signs which are affixed to the equipment. The warning labels must always be legible. Missing or damaged labels must be replaced.

	<p>⚠ DANGER</p> <p>The device conducts hazardous voltages The capacitors and the line and motor terminals may conduct hazardous voltages even when the device is not in service and is disconnected from the line</p> <p>Electric shocks and short-circuits may occur if personnel come into contact with live parts, spill liquids on them or touch them with objects.</p> <ul style="list-style-type: none"> • Avoid any contact with live parts, spilling liquids on them or touching them with objects. • After switching off the power supply, wait at least 5 minutes before opening the device. • Take additional external measures if there is a risk of short-circuits; for example, independent limit switches or mechanical interlocks, etc.
	<p>⚠ WARNING</p> <p>The device controls rotating mechanical parts</p> <p>Contact with them can cause severe physical injuries and serious material damage.</p> <ul style="list-style-type: none"> • Only touch those parts in a stopped state. • Certain parameter settings can cause the variable speed drive to restart automatically after a fault or after a failure in the power supply once the fault is eliminated and acknowledged or after the power supply is restored. • Ensure that the DIP switches are correctly set, and that the inputs are properly configured. Otherwise, the drive can start inadvertently.
	<p>⚠ WARNING</p> <p>The devices may only be installed, commissioned, and maintained by trained personnel.</p> <p>Many dangers, some potentially fatal, are posed by permitting unqualified personnel to work on the device. They may also result in damage to the device and to the plant.</p> <p>▷ Qualified personnel are specialists who possess the skills required to install, mount, commission, operate, and repair the devices. These people must have the following qualifications:</p> <ul style="list-style-type: none"> • They must have received training and be authorized to switch the variable speed drives on and off, to ground the devices in accordance with safety standards and to tag the circuits. They are generally people with expertise in the area of electrical installation or people who work under the supervision of experts, such as qualified electricians. • They have to be familiar with all the safety information, installation and operating instructions contained in this Guide and be trained to perform first aid.

	⚠ CAUTION
	<p>It is only permissible to use the device for the purposes specified by the manufacturer.</p> <p>Unauthorized use or modifications can result in fires, electric shocks and injuries.</p> <ul style="list-style-type: none">• The device may only be used for the intended purpose.• Do not carry out any modifications to the device.• Only use spare parts and accessories which are distributed or recommended by the manufacturer of the device.• Do not use the device as an "emergency stop device" (see EN 60204, 9.2.5.4).

	NOTICE
	<p>The required ambient conditions must be observed.</p> <p>Unsuitable ambient conditions can affect the functions of the device.</p> <ul style="list-style-type: none">• Only install the variable speed drive in areas which are free from jolts, vibrations, electromagnetic fields, and corrosive gases.• Maintain the ambient conditions which are specified in the technical data, such as temperature, pressure, humidity, etc.

1.3 Disclaimer of liability

	NOTICE
	<p>In the event of operation in a fire or in emergency mode, the equipment and device protection functions are disabled.</p> <p>As a result, damage may occur to the device and the equipment.</p> <ul style="list-style-type: none">• Only activate fire or emergency mode if the continuous operation of the drive (fan) is absolutely necessary, e.g., in order to ensure that smoke and heat are extracted in the event of the building being evacuated.

2 Mounting and installation

2.1 Dimension drawings of the PM230

You can find the dimension drawings in the enclosed document, "Getting Started SINAMICS PM230".

2.2 Structure of the Control Unit

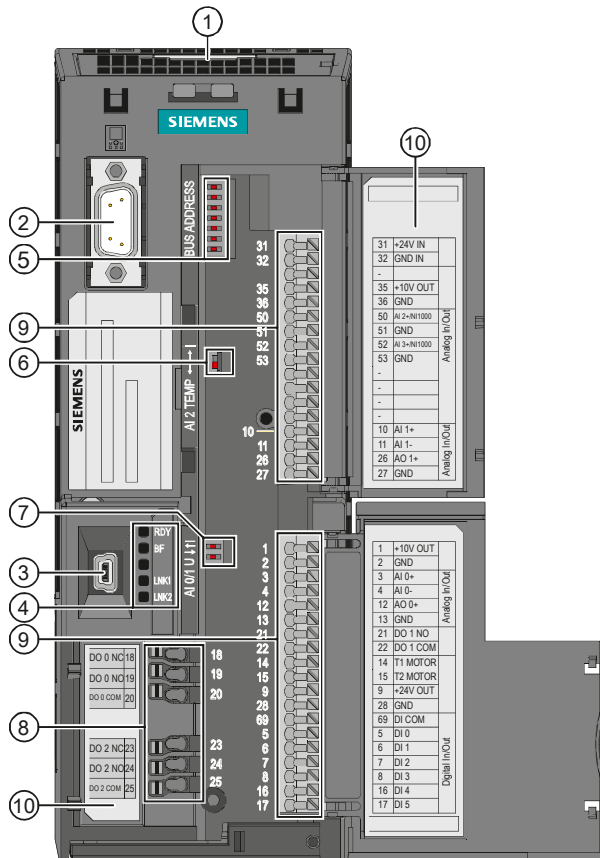

- ① Memory card slot (MMC or SD card)
- ② Interface for an operator panel (IOP or BOP-2)
- ③ USB interface for STARTER
- ④ Status LED

	RDY
	BF

	LNK1, nur bei PROFINET
	LNK2, nur bei PROFINET

- ⑤ DIP switch for fieldbus address (for PROFINET no function)

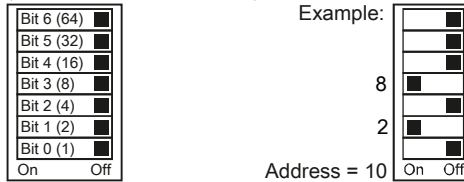

- ⑥ LG-NI1000 Current DIP switch AI2 (terminals 50/51)



- ⑦ DIP switch for AI0 and AI1 (terminals 3/4 and 10/11)

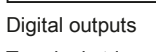

- ⑧ Digital outputs
- ⑨ Terminal strip
- ⑩ Terminal designation
- ⑪ Switch for bus terminating resistor

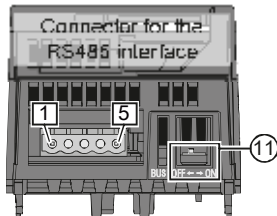

- Pin
- 1 0 V, reference potential
 - 2 RS485P, receive and send (+)
 - 3 RS485N, receive and send (-)
 - 4 Cable shield
 - 5 Not connected

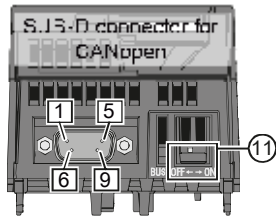

- Pin
- 1 Not assigned
 - 2 CAN_L, CAN signal (dominant low)
 - 3 CAN_GND, CAN ground
 - 4 Not assigned
 - 5 (CAN_SHLD), optional shield
 - 6 (GND), optional ground
 - 7 CAN_H, CAN signal (dominant high)
 - 8 Not assigned
 - 9 Not assigned

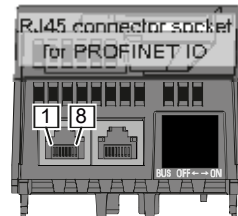

- Pin
- 1 RX+, receive data +
 - 2 RX-, receive data -
 - 3 TX+, Transmit data +
 - 4 Not assigned
 - 5 Not assigned
 - 6 TX-, transmit data -
 - 7 Not assigned
 - 8 Not assigned

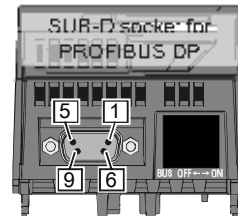

- Pin
- 1 Shield, ground connection
 - 2 Not assigned
 - 3 RxD/TxD-P, receive and send (B/B')
 - 4 CNTR-P, control signal
 - 5 DGND, reference potential for data (C/C')
 - 6 VP, supply voltage
 - 7 Not assigned
 - 8 RxD/TxD-N, receive and send (A/A')
 - 9 Not assigned

2.3 Terminal strips in the Control Unit

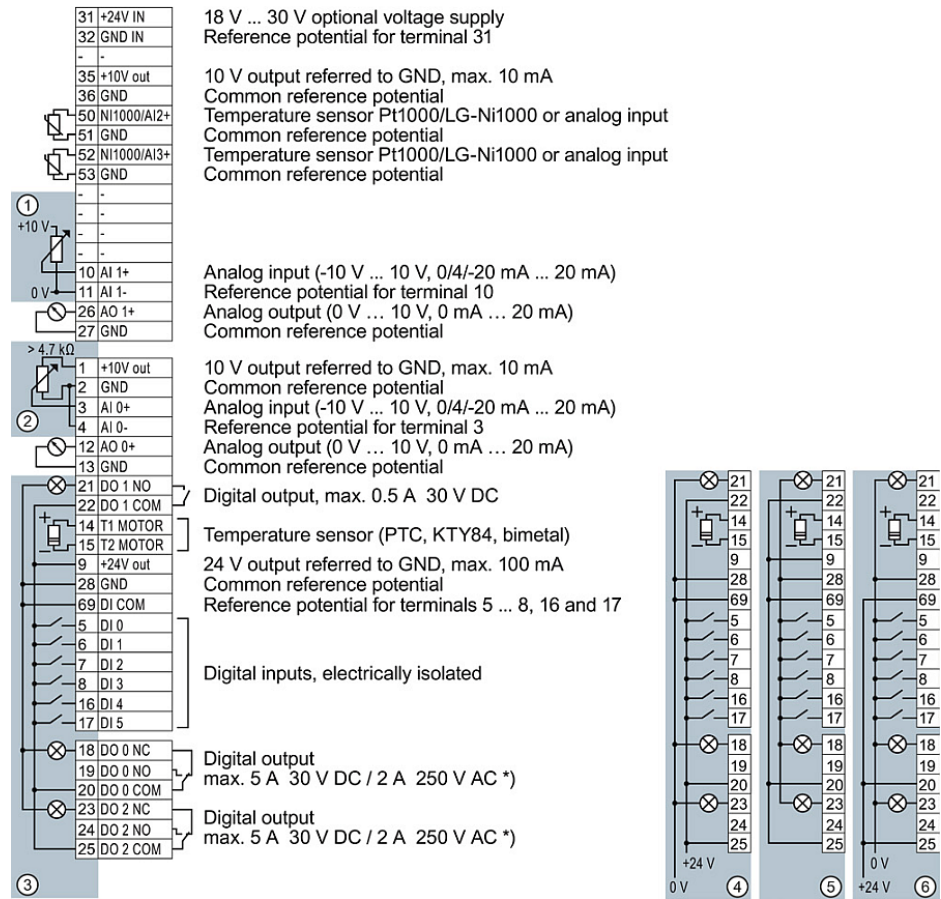

The wiring of the terminal strip is displayed by way of an example for every type of terminal.

If more than 6 digital inputs are required, use terminals 3 and 4 (AI 0) or terminals 10 and 11 (AI 1) as additional digital inputs DI 11 or DI 12.

1. Wiring when using the internal power supplies
DI = high if the switch is closed
2. Wiring when using the external power supplies
DI = high if the switch is closed
3. Wiring when using the internal power supplies
DI = low if the switch is closed
4. Wiring when using the external power supplies
DI = low if the switch is closed

2.4 Motor cable lengths and cross-sections

2.4.1 Cable specifications for conformity with EMC requirements

PM230	Cable type	EMC category	Max. cable length
Filter A	Shielded	C2	25 m (80 ft)

PM230	Cable type	EMC category	Max. cable length
	Shielded	C3	50 m (164 ft)
	Unshielded	None	100 m (330 ft)
Filter B	Shielded	C1 (conducted only)	25 m (80 ft) with IP54 50 m (164 ft) with IP20
	Shielded	C2	50 m (164 ft)
	Unshielded	None	100 m (330 ft)

1. You may only use copper wire of class 1, 75°C (for compliance with the UL in frame sizes A to C).
2. Ensure that the appropriate circuit breakers or fuses with the specified current rating are connected between the power supply and the drive.

2.4.2 Cable cross-sections

Frame size	Power	Cable cross-section		Tightening torques	
	kW	mm ²	AWG	Nm	lbf in
FSA	0.37...1.5	1.0 ... 2.5	18...14	0.5	4.4
	2.2...3	1.5...2.5	16...14	0.5	4.4
FSB	4	2.5...6.0	14...10	0.6	5.3
	5.5...7.5	4.0...6.0	12...10	0.6	5.3
FSC	11	6.0 ... 16	10 ... 5	1.5	13.3
	15...18.5	10 ... 16	7 ... 5	1.5	13.3
FSD	22.0...30	10...35	5...2	6	53
FSE	37	25...50	3...2	6	53
	45	35...50	2...4/0	6	53
FSF	55	70...120	2/0...4/0	13	115
	75...90	95...120	3/0...4/0	13	115

Cable cross-section of the grounding conductors

The material of the protective grounding conductor must be the same as the material of the power cable. If this is not the case, the specific resistance of the protective grounding conductor must not be higher than the specific resistance of the power cables. The relevant diameter of the power cables is the diameter of the line supply cable, and not the diameter of the motor cables.

In the case of power cables up to 35 mm², the ground cable must have a cross-section of at least 10 mm² (16 mm² Al).

It is always advisable to use a 16mm² Cu equipotential bonding conductor at least.

For power cables with a diameter of more than 35 mm², the protective grounding conductor must have at least half of the size of the cross-section of the power cable.

2.5 Wiring sequence for IP55

The requirements and actions for wiring the Power Module correctly are described below.



⚠ DANGER

Electrical voltage can result in death or serious injury.

- Isolate the power supply to the Power Module before commencing the wiring.
- Isolate the power supplies to the Power Module and to the connected Control Unit before installing the cables.
- After isolating the power supply, wait 5 minutes before continuing with the installation.

- ▷ The Power Module has been correctly mounted.
- ▷ The cover of the Power Module has been removed.
- ▷ The Control Unit has been correctly mounted on the Power Module.
- ▷ The electrical installation engineer has read the safety instructions and the procedural instructions, and is in possession of the necessary tools.
- ▷ The electrical installation engineer is familiar with all the local and national safety guidelines for the electrical installation of industrial products.

1. Prepare cables and remove the gland plate

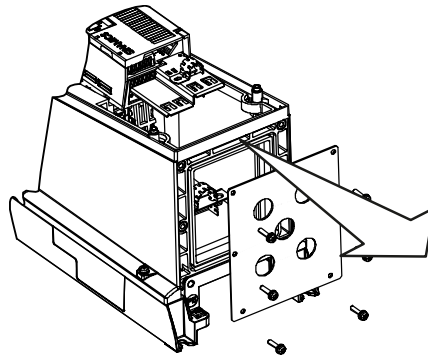

- Prepare the cables. See Cable preparation [→ 12].
- Remove the fixing screws from the gland plate.
- Remove the gland plate.

2. Fasten the cable glands to the cables.

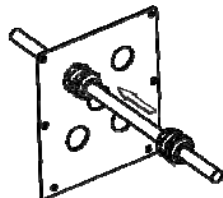

- 3. Ensure that the screws on the cable glands are loosened so that the cables slide through unhindered. See Cable cross-sections [→ 10].
- 4. Attach the ferrite core and shielding

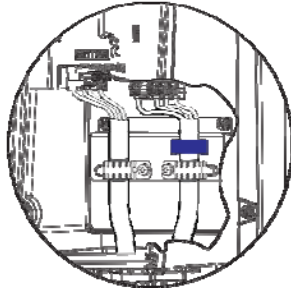

- Attach a ferrite core to the motor cable (only class B filter variants)
- Attach the power and motor cable to the terminals of the Power Module.
- Ensure that the cables are correctly secured through the shielding terminals.

5. Fasten the gland plate

- Press the gland plate against the underside of the Power Module.
- Ensure that the cables are pulled through the cable glands. This prevents excess lengths of cable inside the Power Module enclosure.
- Tighten the gland plate applying a maximum tightening torque of 2 Nm (17.7 lbf.in).
- Check whether the seals are correctly seated; otherwise, it will not have IP55 degree of protection.
- Tighten the cable glands applying a maximum tightening torque of 2.5 Nm (22.12 lbf.in).
- Insert rubber grommets into all the holes of the gland plate which are not occupied by cables.

2.6 Line and motor connections

2.6.1 IP55

2.6.1.1 Cable preparation

In order to achieve EMC category C1 in devices with an EMC filter of class B, the shield must not only be exposed around the length C, it must also be exposed when it is fed through the base plate (see outline, at the end of "D") and must be fed conductively through the EMC cable gland.

No shielding dimensions are indicated for the input power cables because they are generally unshielded cables. The table below helps with correctly preparing the cables for line and motor terminals.

Diagram	Cable type	Dimensions			
		A	B	C	D
	FSA power cables	10 mm 0.39 inches	60 mm 2.36 inches	-	90 mm 3.54 inches
	FSA motor cables	10 mm 0.39 inches	60 mm 2.36 inches	10 mm 0.39 inches	60 mm 2.36 inches
	FSB power cables	10 mm 0.39 inches	60 mm 2.36 inches	-	50 mm 1.96 inches
	FSB motor cables	10 mm	50 mm	10 mm	40 mm

Diagram	Cable type	Dimensions			
		A	B	C	D
		0.39 inches	1.96 inches	0.39 inches	1.57 inches
	FSC power cables	10 mm 0.39 inches	50 mm 1.96 inches	-	70 mm 2.75 inches
	FSC motor cables	10 mm 0.39 inches	50 mm 1.96 inches	10 mm 0.39 inches	40 mm 1.57 inches

2.6.1.2 FSA - FSC

The following diagram shows the arrangement of the line and motor terminals on the Power Module of frame sizes FSA to FSC. The tightening torques for the terminals are indicated in the diagram.

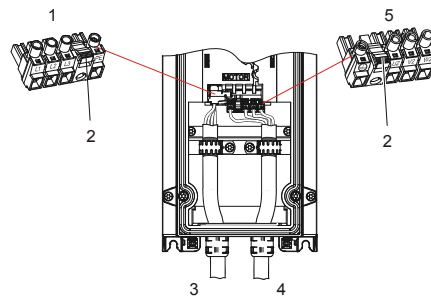

1. Detachable current connection
2. Connector-disengaging device
3. Connection of supply voltage
4. Motor connection
5. Detachable motor connector

FSA: 0.5 Nm (4.4 lbf.in)
 FSB: 0.6 Nm (5.3 lbf.in)
 FSC: 1.5 Nm (13.3 lbf.in)

2.6.1.3 FSD- FSF

The following diagram shows the arrangement of the line and motor terminals on the Power Module of frame sizes FSD to FSF. The tightening torques for the terminals are indicated in the diagram.

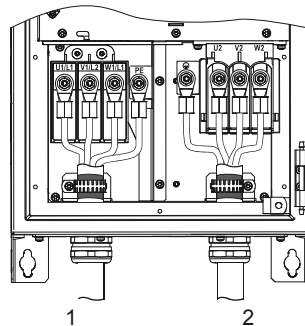

1. Connection of supply voltage
2. Motor connection

FSD: M6: 6 Nm (53.0 lbf.in)
 FSE: M6: 6 Nm (5.3 lbf.in)
 FSF: M8: 13 Nm (115 lbf.in)

2.6.2 IP20

2.6.2.1 FSA...FSC

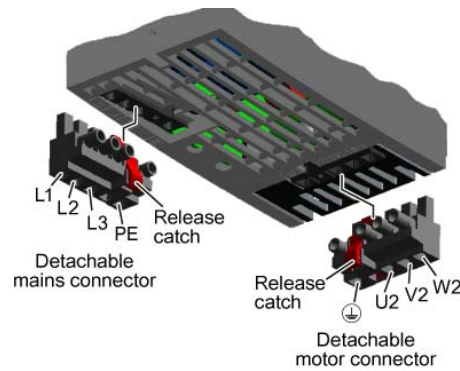

Tightening torques:

- FSA: 0.4 Nm...0.5 Nm
- FSB: 0.55 Nm...0.6 Nm
- FSC: 1.2 Nm...1.5 Nm
-

The Power Modules are equipped with two-part connectors. You can remove the detachable part of the connector from the Power Module by pressing the unlocking device. The connectors cannot be mixed up.

2.6.2.2 FSD...FSF

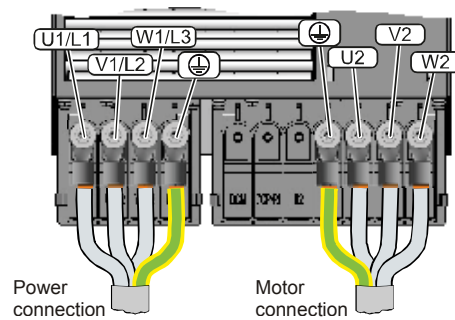

Tightening torques:

- FSA: 6 Nm
- FSB: 6 Nm
- FSC: 13 Nm

Accessing line and motor terminals

1. Loosen the safety catch on the sides of the terminal covers using a suitable size of flat-head screwdriver.

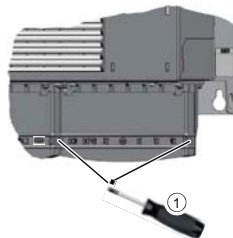

2. Turn the terminal cover up and allow it to engage.

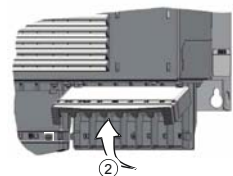

2.7 EMC directives

1. Connections and interference suppression

- Create the connections as permanent connections.
- Use special washers which penetrate the insulation surface for screw connections on painted or anodized metal components. This serves to create a metallically conducting contact. Or remove the insulation surface at the contact points.
- Contactor coils, relays, solenoid valves, and motor holding brakes must feature interference suppressors which reduce high frequency interference when the contacts are opened. Interference suppressors are RC elements or varistors for AC-operated coils and freewheel diodes for DC-operated coils. Connect the interference suppressors directly to the corresponding coil.

2. Cabling

- Keep the wiring as short as possible.
- Lay signal and data cables as well as the equipotential bonding cables parallel and as close to one another as possible.
- Ground replacement wires for signal and data cables at either end in the sense of additional shielding.
- Lay line and motor cables separate from the signal and data cables. Maintain a minimum clearance of approximately 25 cm.
- Shield the power cable between the drive and the motor. Use three-core, symmetrical three-phase cable. Shielded cables with three symmetrical phase conductors (L1, L2 and L3) as well as an integrated, three-core and symmetrically arranged PE conductor are ideally suited for this.
- Lay the shielded power cable to the motor separately from the two motor temperature sensor cables (PTC/KTY) because they are treated like signal cables.
- Shield signal and data cables in order to avoid inductive or capacitive interference or stray radiation.
- Lay particularly sensitive signal cables, such as setpoint or actual value cables, in such a way that optimized and interruption-free shield bonding exists at either end.
- Where possible, lay cable shields immediately after the point where the cable enters the control cabinet or, in the case of IP55 type of equipment, at the designated points.
- Use EMC shield bars for power cables and use the shield support elements provided in the drive for signal and data cables (shield connection kit for the Control Unit).

3. Cable shields

- Use shielded cables with finely stranded braided shields. Foil shields are not suitable because they are considerably less effective.
- Lay the shields over as large a surface as possible at either end, with optimized electrical conductivity to the grounded enclosure. This is the only way of reducing inductive or capacitive interference or stray radiation to a minimum.

- Where possible, lay the cable shields directly behind the cable entry into the drive. In the case of signal and data cables, use the shield connection points which are provided in the control cabinets or the shield connection kit for the Control Unit.
- Avoid interruptions in cable shields caused by intermediate terminals or service switches without a conductive metal housing.
- Fasten the cable shields both for power cables as well as for signal and data cables using the appropriate EMC shield clamps (use the shield connection kit supplied for the Control Unit) or EMC cable glands. The shield clamps must connect the shield to the EMC shield bar or the shield support element for control cables through a low inductive connection over a large surface area.

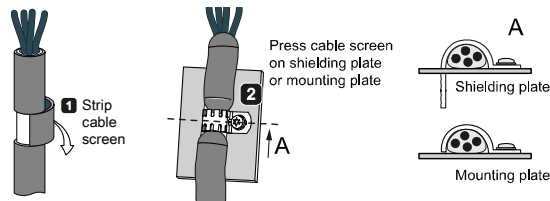

2.7.1 IP55

2.7.1.1 Equipment design

Drives with IP55 degree of protection / UL Type 12 (Power Module PM230) can be installed and operated in a closed control cabinet as well as without a control cabinet.

- Shielding of the drive to comply with EMC standards
 - Use a shielded cable if terminal wiring is required for the Control Unit. Guide this through the base plate and place the shield either on the shield connection kit of the Control Unit or using the EMC cable gland.
 - Expose the motor cable shield at the point where the cable is fed through the base plate and ensure that it is in complete contact with an EMC cable gland. It is important for the shield to be fed through the cable gland and then to be connected at the designated place inside the enclosure once again. This ensures that both the gland plate and the enclosure are in contact with the shield.
 - Feed the motor cable through the right-hand opening on the gland plate, in particular in the case of Power Modules of frame size C and with filter class B.

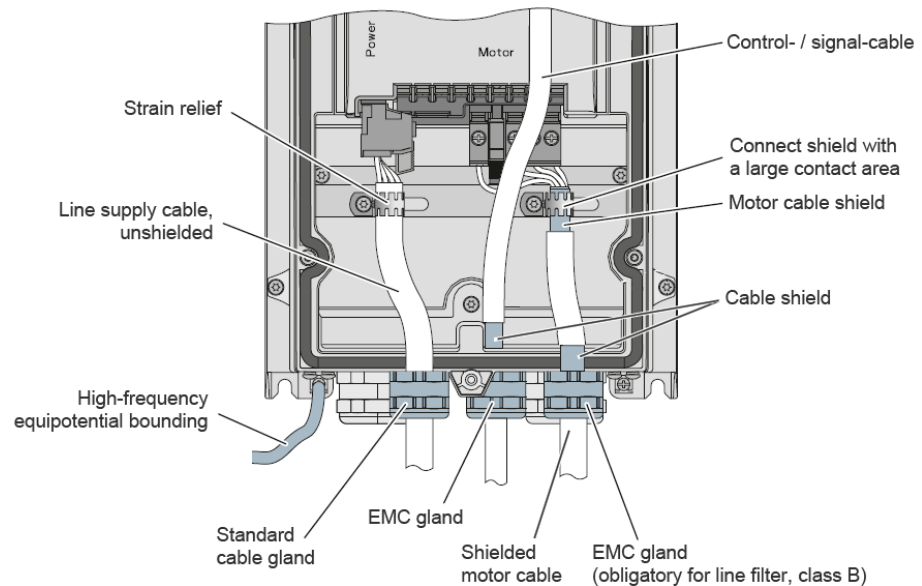

2.7.1.2 Attaching ferrite rings to motor and line cables

- ▷ In the case of PM230 Power Modules of frame sizes A to C (0.37 kW...15 kW) with integrated class B filters, attach the colored ferrite ring to the motor power cable in order to meet the requirements set out in EMC category C1 for conducted interference emissions.
 - Colored ferrite ring for motor cables
 - Attach the colored ferrite ring between the terminals of the motor power cable and the shielding plate of the Power Module.
 - Use cables which are shorter than 25 m. Ferrite rings may not be attached to cables measuring more than 25 m (80 ft) in length.
 - ⇒ The required ferrite rings for PM230 FSA to FSC Power Modules with integrated class B filters are included in the scope of supply for the product.
- ▷ In the case of PM230 Power Modules of frame size B (4 kW...7.5 kW) and design C (11 kW ... 15 kW) with integrated class B filters, the gray ferrite rings also have to be attached to the line cable in order to meet the requirements set out in the EMC guidelines for radiated noise.
 - Ferrite rings for line cables
 - Attach the gray ferrite rings between the terminals and the shielding plate on the line cable.
 - ⇒ The gray ferrite rings are included in the scope of supply for the product.

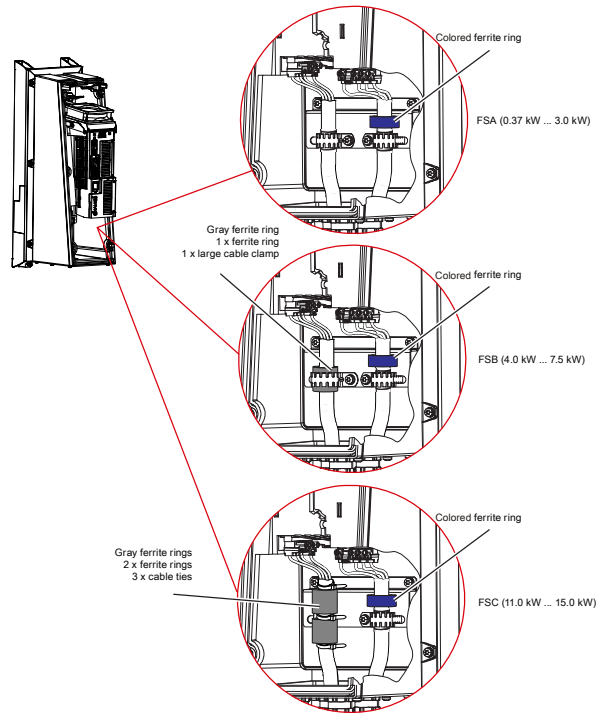

2.7.2 IP20

!	<p>NOTICE</p> <ul style="list-style-type: none"> Only install and operate IP20 degree of protection drives in a closed control cabinet.
----------	---

2.7.2.1 Equipment design

The drives are designed for operation in industrial environments where high values of electromagnetic interference are reached. Safe, reliable and disturbance-free operation is only ensured if the control cabinet is professionally installed.

- Connect all the metallic parts of the control cabinet (side plates, rear panels, top and base plates) to the frame of the cabinet with good electrical conductivity. Make the connections as two-dimensional as possible or establish them using a large number of point-like screw connections
- Connect the PE bar and the EMC shield bar to the control cabinet frame through a good electrical connection established through a large surface area
- Connect all the metal enclosures of the devices and supplementary components installed in the cabinet – e.g. drive or line filter over a large area and with good conductivity. It is best to mount these devices and supplementary components on a mounting plate which is bright and offers good conductivity. Connect them, in turn, to the control cabinet frame and, in particular, to the PE bar and EMC shield bar over a large area and with good conductivity
- Follow the instructions in section EMC directives [→ 15] "Connections and interference suppression"

2.7.2.2 Installation of the Power Modules



Use an unshielded cable for the line supply connection for Power Modules with an integrated filter.

If you connect the Power Module to the line supply via an external filter, use a shielded cable between the line filter and the Power Module.

The EMC-compliant installation of the Power Modules is shown in the following diagram using two examples.

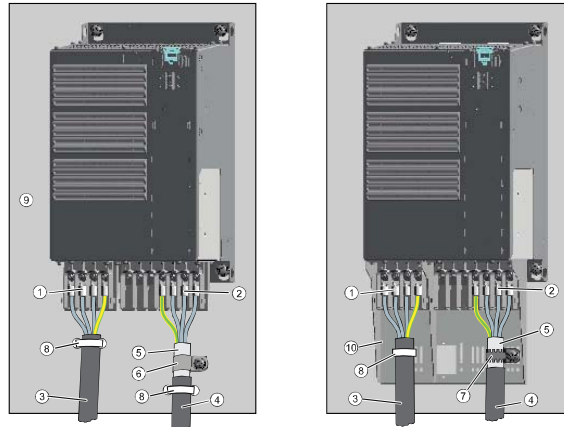

1	Line connection	6	Cable clamps for the connection between the shield and the mounting plate
2	Motor connection	7	Serrated collar
3	Line supply cable (unshielded)	8	Cable tie
4	Motor connection cable (unshielded)	9	Metal mounting plate
5	Cable shield	10	Shield plate

1. Shielding with a shield plate

- There are shield connection kits for all sizes of Power Modules. Shield connection kits for sizes FSD...FSF must be ordered separately. Connect the cable shields to the shield plate over a large area with shield clamps.

2. Shielding without a shield plate







- EMC-compliant shielding can also be implemented without using a shield plate. In this case, you must ensure that the cable shields are connected to the ground potential over a large area.

3 Commissioning

3.1 Operator panels

3.1.1 IOP

3.1.1.1 Functions













Button	Function
	Turning the navigation wheel: <ul style="list-style-type: none"> ● Changing selection ● Changing parameters <ul style="list-style-type: none"> – Clockwise rotation increases the value. – Counter-clockwise rotation reduces the value. Pressing the button <ul style="list-style-type: none"> ● Confirming the selection Pressing and holding down the button (> 3 s) <ul style="list-style-type: none"> ● Toggling between changing individual digits and changing the whole value
	<ul style="list-style-type: none"> ● In AUTO mode: no function ● In MANUAL mode: pressing starts the drive
	<ul style="list-style-type: none"> ● In AUTO mode: no function ● In MANUAL mode: <ul style="list-style-type: none"> – Pressing briefly: OFF1 - the motor comes to a standstill along the set down ramp (parameter P1121) – Pressing and holding down the button (> 3 s) or pressing it briefly twice: The motor coasts to a standstill
	<ul style="list-style-type: none"> ● Pressing briefly: Return to the previous display ● Pressing and holding down the button (> 3 s): The IOP returns to the status screen
	Pressing the button: <ul style="list-style-type: none"> ● Information output about the actual display ● You return to the previous display by pressing again
	<ul style="list-style-type: none"> ● Pressing the button: Toggling between external command sources and the IOP as command source. <ul style="list-style-type: none"> – MANUAL means: Manual control using the IOP buttons – AUTO means: The drive responds to external control commands (e.g. fieldbus or terminals)



When you toggle to MANUAL mode, the motor continues running at the last setpoint speed selected.







When you toggle to AUTO mode, the motor stops.

3.1.1.2 Screen symbols

Function	Status	Symbol	Remark
Command source	Auto		
	JOG	JOG	Is displayed if the JOG function is activated
	Manual		
Drive state	Ready		
	In operation		Symbol rotates when the motor is running.
Fault display	Fault		
Alarm display	Alarm		
Save in the RAM	Active		Data is saved in the RAM. If the power supply is interrupted, all data is lost.
PID autotuning	Active		
Hibernation	Active		
Write protection	Active		Parameters cannot be changed.
Know-how protection	Active		
ESM	Active		Essential services mode (fire control)

3.1.2 BOP-2

3.1.2.1 Functions



Button	Function
	<ul style="list-style-type: none"> Pressing the button: Confirming the selection Pressing and holding down the button (> 3 s): Toggling between changing individual digits and changing the whole value
	<ul style="list-style-type: none"> Pressing the button <ul style="list-style-type: none"> Scrolling up through the menu Increasing a parameter value Pressing the UP and DOWN buttons simultaneously when MANUAL and JOG mode are activated: Switching the reverse function on and off
	<ul style="list-style-type: none"> Pressing the button <ul style="list-style-type: none"> Scrolling down through the menu Reducing a parameter value Pressing the UP and DOWN buttons simultaneously when MANUAL and JOG mode are activated: Switching the reverse function on and off
	<ul style="list-style-type: none"> Pressing briefly: Return to the previous display Pressing and holding down the button (> 3 s): The BOP-2 returns to the status screen
	<ul style="list-style-type: none"> In AUTO mode: no function In MANUAL mode: pressing starts the drive
	<ul style="list-style-type: none"> In AUTO mode: no function In MANUAL mode: <ul style="list-style-type: none"> Pressing briefly: OFF1 - the motor comes to a standstill along the set down ramp (parameter P1121)

Button	Function
	<ul style="list-style-type: none"> Pressing and holding down the button (> 3 s) or pressing it briefly twice: The motor coasts to a standstill
	<ul style="list-style-type: none"> Pressing the button: Toggling between external command sources and the BOP-2 as command source. <ul style="list-style-type: none"> MANUAL means: Manual control using the IOP buttons AUTO means: The drive responds to external control commands (e.g. fieldbus or terminals)



You can also toggle between MANUAL and AUTO mode when the motor is running.

3.1.2.2 Screen symbols

Function	Status	Symbol	Remark
Command source	Manual		No symbol is displayed if AUTO mode is activated
Drive state	Ready		Steady-state symbol, does not rotate
JOG function	Active	JOG	Is displayed if the JOG function is activated
Fault or alarm display	Fault or alarm		<ul style="list-style-type: none"> Flashing symbol <ul style="list-style-type: none"> There is a fault present. The drive stops. Clear the fault. Permanent symbol <ul style="list-style-type: none"> There is an alarm (e.g., overtemperature) The drive keeps running.

3.1.3 Saving drive data on a ROM

This option allows you to transfer all the drive data from the drive's internal memory (RAM) manually to the non-volatile memory (ROM). This is necessary if changes have been made via the STARTER commissioning software or if the IOP is in "Save to RAM" mode.

▷ IOP

1. Select Options > Save RAM to ROM.

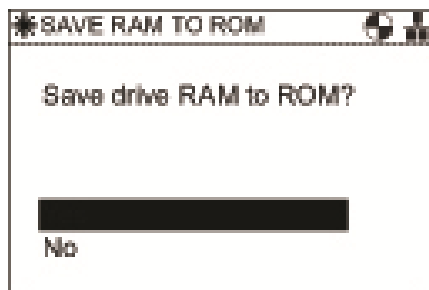

2. Confirm with OK.

▷ BOP-2

1. Select Options > RAM to ROM.



2. Confirm with OK.

⇒ All the data is saved onto the drive until it is overwritten via a further RAM to ROM command.

3.2 Preparing for commissioning

Prior to commissioning, you should have an answer to the following questions:

- Which communication protocol does the drive use?
 - ⇒ See section Communication [→ 30].
- In which region is the motor being used?
 - ⇒ See [p0100] "Motor standard IEC/NEMA" BOP-2 in Basic commissioning with the wizard [→ 24].
- What type of control is needed for the application?
 - ⇒ See [p1300] "Control type" Additional important parameters [→ 29].
- Which speed limits does the motor use?
 - ⇒ See [p1080] and [p1082] "Minimum and maximum speed" Setting the ramp-function generator [→ 27].
- What motor ramp-up time and ramp-down time are needed for the application?
 - ⇒ See [p1120] and [p1121] "Ramp-up and ramp-down time" Setting the ramp-function generator [→ 27].

3.3 Basic factory settings

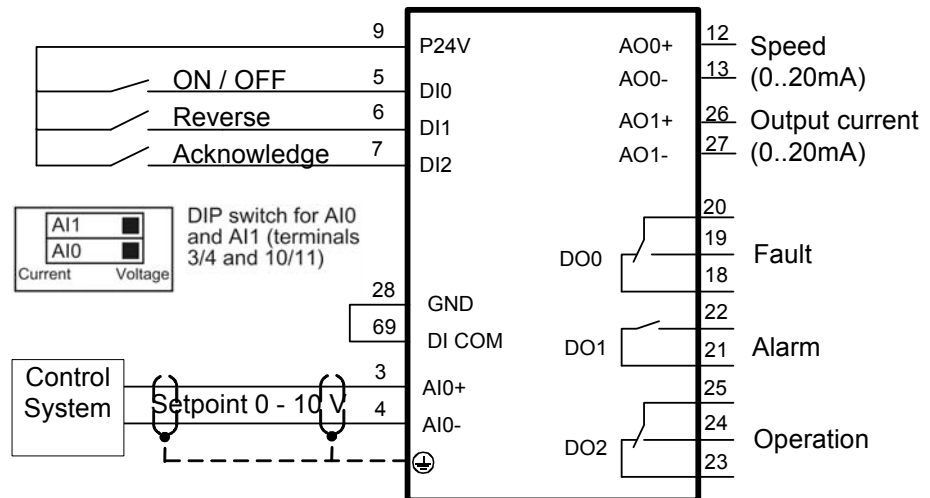

Figure 1: Terminal assignment in the factory settings (corresponds to MacPar15 = 12)

3.4 Basic commissioning with the wizard

There are essentially four steps to commissioning with the wizard:

1. Reset to factory settings
Restore the drive to the factory settings. This ensures that the drive is in a defined basic setting.
2. Execute basic commissioning with the wizard
Basic commissioning includes all the important settings. You can check the data before saving the settings using the wizard.
3. Change the most important settings manually (optional)
You can then change the settings of your drive once again.
4. Create a backup copy of the data on a memory card (MMC or SD).

!	<p>NOTICE</p> <p>The drives are preset in the factory for applications using 4-pole three-phase induction motors that correspond to the performance data of the drive.</p> <ul style="list-style-type: none"> • If you are using the STARTER commissioning tool and a Siemens motor, enter the order number for the motor. The data is applied automatically. • If you are not using a Siemens motor, read the data from the motor's rating plate and enter the appropriate parameters manually.
----------	---

Example: Rating plate details and their assignment to the drive parameters:

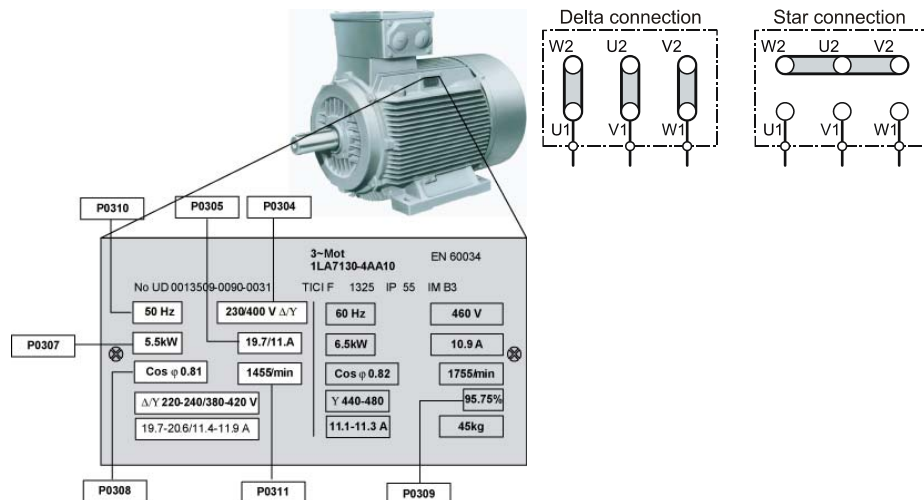

!	<p>NOTICE</p> <p>The entry of the rating plate data must match the interconnection of the motor (star (wye) circuit [Y] / delta circuit [Δ]).</p> <ul style="list-style-type: none"> • Enter the delta rating plate data in the case of a motor delta circuit.
----------	--









3.4.1 IOP



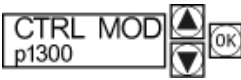

In the menu, select "Wizard" → "Basic commissioning". The wizard will guide you through the commissioning process. You will find further descriptions of the parameters in the next section, "BOP-2".

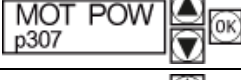
3.4.2 BOP-2

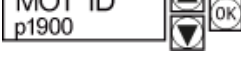
The commissioning wizard steps are set out in the table below.

	<p>⚠ CAUTION</p> <p>Motor data identification in applications with hazardous loads</p> <p>Risk of injury due to uncontrolled movements</p> <ul style="list-style-type: none"> Secure dangerous plant and system parts before starting the motor data identification, e.g. by fencing off the dangerous location or lowering suspended loads.
---	---

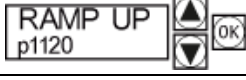
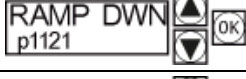
Menu	Description
	Set all parameters for the "SETUP" menu.
	Before commissioning, restore all the parameters to the factory settings.
	Set the type of control of the motor. <ul style="list-style-type: none"> 0: V/f control with linear characteristic 1: Linear V/f characteristic with Flux Current Control (FCC) 2: V/f control with parabolic characteristic (factory setting) 4: Linear V/f characteristic with ECO 7: Parabolic V/f characteristic with ECO 20: Vector control without speed encoder
	Motor standard: IEC or NEMA <ul style="list-style-type: none"> 0: IEC motor (50 Hz, SI units) 1: NEMA motor (60 Hz, US units) 2: NEMA motor (60 Hz, SI units)
	Motor voltage in [V]
	Motor current in [A]
	Motor power in [kW] or [hp]
	Motor rated speed in [rpm]
	Identification of the motor data: <ul style="list-style-type: none"> STILL ROT: Identify motor data with the motor rotating. STILL: Identify motor data at standstill. The motor does not rotate. <p>We recommend the setting STILL ROT if the motor can rotate freely and if the P1300 control type is set to vector control. In the case of</p>

Menu	Description
	V/f control, the rotating measurement is not conducted.
	Define the preassignment for inputs and outputs via one of the macros to activate the drive. <ul style="list-style-type: none"> ● 12: Switch-on via DI0, setpoint via AI0 (factory setting) ● 108: Switch-on and setpoint via USS ● 109: Switch-on and setpoint via Modbus ● 110: Switch-on and setpoint via BACnet
	Minimum motor speed [rpm]
	Motor ramp-up time [s]
	Motor ramp-down time [s]
	Parameter p3900: The basic commissioning has been completed. Confirm the settings made.



NOTICE

If the drive has still not identified the motor data, alarm A07991 is output.

- Switch on the motor so that the drive can identify the motor data. The drive switches off the motor after the identification has been completed.
- The motor identification process may take several minutes. Do not interrupt the process and do not disconnect the variable speed drive from the line during this time.
- Following the motor identification, save it from RAM to ROM in order to protect it.



In firmware < 4.6, the motor only starts to rotate if there is a setpoint greater than 0 % in addition to release. This also applies in AUTO and MANUAL modes

3.5 Additional settings

3.5.1 Resetting to factory settings

This function restores the drive to factory settings.



The communication settings and the settings of the motor standard (IEC/NEMA) are retained after resetting.

▷ STARTER

1. Go online with STARTER.

2. Click on the  button.

▷ IOP

1. Select Options > Parameter settings > Reset drive to factory settings.
 2. Confirm with OK.
- ▷ BOP-2
1. Select Options > DRVRESET in the menu.
 2. Confirm with OK.

3.5.2 Setting the ramp-function generator

You can set the speed limits and the ramp-up and ramp-down times here.

Parameter	Possible settings
p1080	Minimum speed in [rpm]
p1082	Maximum speed in [rpm]
p1120	Ramp-up time of the motor after switching on in [s]
p1121	Ramp-down time of the motor after switching off in [s]

The minimum speed and maximum speed of the motor are dependent upon the speed setpoint and the rated speed of the motor. Refer to the overview below:

% of the synchronous speed	Hz	Four-pole motor (rpm)	Two-pole motor (rpm)
10	5	150	300
20	10	300	600
30	15	450	900
40	20	600	1200
50	25	750	1500
60	30	900	1800
70	35	1050	2100
80	40	1200	2400
90	45	1350	2700
100	50	1500	3000
110	55	1650	3300
120	60	1800	3600

The ramp-up and ramp-down time define the maximum motor acceleration when the speed setpoint changes. The ramp-up and ramp-down time is the time between motor standstill and the maximum speed, or between the maximum speed and motor standstill.

Factory settings:

- Minimum speed [p1080] - factory setting 0 [rpm]
- Maximum speed [p1082] - factory setting 1500 [rpm]
- Acceleration time [p1120] - factory setting 10 s
- Deceleration time [p1121] - factory setting 10 s

Recommended ramp times	
0.37 – 3kW	30 s
4 – 15 kW	60s
18.5 – 30 kW	90s
37 – 90 kW	120s

3.5.3 Setting the PID controller

If the PID controller is activated, the set ramp times are bypassed in p1120 and p1121.

- Therefore, define the following settings for smoothing times, ramp times and controller.

Parameter	Setting	Function
p2200	1	Setting of the signal source for switching the technology controller on/off.
p2253	r2224	Technology controller setpoint <ul style="list-style-type: none"> • r755.0: Analog setpoint (AI0) • r2224: Technology controller fixed value • r2050.1: Setpoint fieldbus
p2257	30s *	Technology controller setpoint ramp-up time
p2258	30s *	Technology controller setpoint ramp-down time
p2264	r755.1	Technology controller actual value r755.1: Analog actual value (AI1)
p2265	10s *	Technology controller actual value filter time constant
p2267	120%	Technology controller upper limit actual value
p2268	-20%	Technology controller lower limit actual value
p2280	1	Technology controller proportional gain
p2285	30s *	Technology controller integral time
P2293	30s *	Technology controller ramp-up/ramp-down time
p2306	0	Technology controller fault-signal inversion (heating or cooling)

* The time settings, such as "Technology controller integral action time" are dependent on the used frame size. For additional information on this topic, refer to section Setting the ramp-function generator [→ 27].

The recommended PID controller settings can be parameterized via a macro:

P0010 = 1

P0015 = 120 "PID settings for pumps or fans (only for optimization)"

P0010 = 0

3.5.4 Transferring the license terms

The drive contains open source software (OSS). The license terms for the open source code are saved in the drive.

How to transfer the OSS license terms from the drive to a PC:

1. Switch off the drive power supply.
2. Insert an empty memory card into the card slot of the drive.
3. Switch on the drive power supply.
4. When you have switched on the power supply, wait 30 seconds. During this time, the drive writes the "Read_OSS.ZIP" file onto the memory card.
5. Switch off the drive power supply.
6. Remove the card from the drive.
7. Use a card reader and load the file to a PC.

3.6 Additional important parameters

Parameter	Factory setting	Function
p0601	0	Motor temperature sensor type: 0: No sensor 1: PTC warning & timer 2: KTY84 4: Bimetallic NC contact alarm & timer
p0730	r52.3	Digital output 0: Fault active
p0731	r52.7	Digital output 1: Alarm active
p0732	r52.2	Digital output 2: Operation enabled. Motor in operation.
p0748	000	Invert digital outputs (0 = do not invert, 1 = invert) Bit 0: DO 0 Bit 1: DO 1 Bit 2: DO 2
r0755[0..3]	-	Analog inputs, actual value in percent
p0756 [0]	-	AI 0 (0-4)
p0756 [1]	-	AI 1 (0-4)
p0756 [2]	-	AI 2 (2-3, 6-8)
p0756 [3]	-	AI 3 (6-8)
		0: Unipolar voltage input (0 V...10 V) 1: Unipolar voltage input monitored (2 V... 10 V) 2: Unipolar current input (0 mA...20 mA) 3: Unipolar current input monitored (4 mA...20 mA) 4: Bipolar voltage input (-10 V...10 V) 6: LG-Ni1000 temperature sensor (-50 °C...150 °C) 7: PT1000 temperature sensor (-50...250 °C) 8: No sensor connected
p0771[0]	-	AO 0
p0771[1]	-	AO 1
		Important status signals: 0: Analog output locked 21: Speed actual value 24: Output frequency smoothed 25: Output voltage smoothed 26: DC link voltage smoothed 27: Actual current value (smoothed absolute value)
p0776[0, 1]	-	Analog outputs, type 0: Current output (0 mA...20 mA) 1: Voltage output (0 V...10 V) 2: Current output (4 mA...20 mA)
p0840	r0722.0	ON/OFF1 signal source
p0852	1	Enable operation Is used to let the motor coast to a standstill if the ON command is enabled. Example: P0852 = r0722.0.
p1000	2	Speed setpoint selection 2 = Analog setpoint 3 = Fixed speed 6 = Fieldbus. For further values, see the List Manual
p1082	1500 rpm	Maximum speed The reference speed (p2000) must also be taken into consideration.
p1113	r722.1	Invert direction of rotation
p1200	0	Flying restart selection: 0: Flying restart inactive 1: Flying restart always active (start in setpoint direction) 4: Flying restart always active (start only in setpoint direction)
p1210	0	Automatic restart: 0: Disables automatic restart

Parameter	Factory setting	Function
		1: Acknowledges all faults without restarting 4: Restart after line supply failure, without additional start attempts 6: Restart after a fault with additional start attempts 14: Restart after line supply failure following manual acknowledgement 16: Restart after fault after manual acknowledgement 26: Acknowledging all faults and restarting for an ON command Recommended setting: 26 During the restart waiting time, the alarm A07321 appears at FW < 4.6.
p1213[0]	60s	Restart monitoring time: Set this value to 0s for FW < 4.6; otherwise the error F07320 is output if there has been no release.
p1300	2	Open-loop/closed-loop control operating mode: 0: V/f control with linear characteristic 1: V/f control with linear characteristic and FCC 2: V/f control with parabolic characteristic 4: V/f control with linear characteristic and ECO 7: V/f control with parabolic characteristic and ECO 20: Speed control (without encoder)
p1820	0	Change the direction of rotation of the motor: 0: Off 1: On
p1800	4 kHz	Pulse frequency
p1900	0	Motor data identification: 0: Disabled 1: Motor data identification at standstill and when the motor is rotating 2: Motor data identification at standstill 3: Motor data identification when the motor is rotating It is imperative that this is carried out when using SLVC (P1300 = 20).
p2000	1500 rpm	Reference speed relative to a setpoint of 100%
p2103	r722.2	Acknowledge faults
p3880	0	ESM activation of the signal source via digital input
p3881	0	ESM setpoint source: 0: Last known setpoint (r1078 smoothed) 1: Fixed speed setpoint 15 (p1015) 2: Analog setpoint AI0 (r0755[0]) 3: Setpoint from the fieldbus 4: Setpoint from the technology controller 6: Enable OFF1 reaction 7: Enable OFF2 reaction
p8400	0	Time of real-time clock: [0] = Hours (0 ... 23) [1] = Minutes (0 ... 59) [2] = Seconds (0 ... 59)
p8401	1.1.1970	Date of real-time clock: [0] = Day (1 ... 31) [1] = Month (1 ... 12) [2] = Year (YYYY)

3.7 Communication

- ▷ Perform basic commissioning first of all.

1. Select the macro (MacPar) 108 (USS fieldbus), 109 (Modbus), 110 (BACnet), 114 (P1 fieldbus) in the last stage of basic commissioning.
2. If the basic commissioning has already been performed, change the value manually, for example:
P0010 = 1 (parameter filter quick commissioning)
P0015 = 108 (macro 108)
P0010 = 0 (parameter filter ready)
3. If the communication function is only to monitor the drive, but not to control it, proceed as follows:
 - Basic commissioning with macro 108, 109 or 110.
 - P0010 = 1 (parameter filter quick commissioning)
P0015 = 12 (macro 12, control via digital input and analog setpoint)
P0010 = 0 (parameter filter ready)



The "Unit switchover" function is not permissible with this bus system.

3.7.1 RS485 interface

Integration into Design

See Engineering Manual TX G120P (document ID: CM110576xx_01).

Interfacing to a network

1. Connect the drive to your fieldbus via the RS485 interface. This connector has short-circuit proof, isolated pins.
2. Connect the bus terminating resistor for the first and last stations.

When the bus is operating, the first and last bus station must be continuously connected to the supply.

The maximum cable length is 1200 m (3300 ft).



Supply the Control Unit with 24 V DC via terminals 31 and 32 to enable communication to continue to take place with the controller when the line voltage is switched off.

See also Structure of the Control Unit [→ 8].

Setting the address

1. Set the drive's fieldbus address either using the DIP switch on the Control Unit or via parameter p2021.
 2. The positions and settings of the DIP switches are described in Structure of the Control Unit [→ 8].
- ⇒ If you have specified a valid address using DIP switches, this address will always be the one that takes effect, and p2021 cannot be changed.
- ⇒ If you set all DIP switches to "OFF" (0), then p2021 defines the address.

!	NOTICE
	<p>A bus address, baud rate or protocol selection that has been changed only becomes effective once the drive has been switched off and back on again.</p> <p>Restart the drive after changing the bus address.</p>

3.7.2 USS protocol

Using the USS protocol (Universal Serial Interface), users can set up a serial data connection between a higher-level master system and several slave systems (RS 485 interface). Master systems can be building services control systems (e.g., Desigo), programmable logic controllers or PCs.

3.7.2.1 Basic settings

Parameter	Description		
p0015	Macro drive unit <ul style="list-style-type: none"> During the basic commissioning, select the value 108 "USS fieldbus", or with firmware < 4.6 the value 21. 		
p2020	Value	Baud rate	
	4	2400	
	5	4800	
	6	9600	
	7	19200	
	8	38400	
	9	57600	
	10	76800	
	11	93750	
	12	115200	
	13	187500	
	p2021	Valid USS addresses: 1...30 Invalid USS addresses: 0.31...127	
	p2022	Fieldbus interface USS PZD number <ul style="list-style-type: none"> Setting the number of 16-bit words in the PZD part of the USS telegram 	
p2023	Fieldbus interface USS PKW number <ul style="list-style-type: none"> Setting the number of 16-bit words in the PKW part of the USS telegram 		
	0	0 words	
	3	3 words	
	4	4 words	
	127	Variable number of words	
p2030	Fieldbus protocol selection <ul style="list-style-type: none"> 1: USS 		
p2040	Fieldbus interface, monitoring time [ms] <ul style="list-style-type: none"> Setting the time to monitor the process data received via fieldbus. If no process data is received within this time, an appropriate message is output The setting 0 ms deactivates the monitoring. 		

3.7.3 Modbus RTU protocol

3.7.3.1 Overview

The Modbus protocol is a communication protocol with linear topology based on a master/slave architecture. In the Modbus RTU (Remote Terminal Unit), the data are transferred in binary format and the data throughput is greater than in ASCII code.

The Control Unit supports Modbus RTU as a slave with even parity.

1 bit Start	8-bit data	1 bit Parity even	1 bit Stop
----------------	------------	----------------------	---------------

3.7.3.2 Basic settings

Parameter	Description
p0015	Macro drive unit <ul style="list-style-type: none"> During the basic commissioning, select the value 109 "Modbus RTU", or with firmware < 4.6 the value 21.
p2030	Fieldbus protocol selection (only with firmware < 4.6) <ul style="list-style-type: none"> 2: Modbus
p2021	Valid Modbus RTU addresses: 1...247 Invalid Modbus RTU address: 0
p2020	Fieldbus baud rate <ul style="list-style-type: none"> Baud rates from 4800 bps to 187500 bps can be set for communication. Factory setting: 19200 bps
p2024	Modbus timing <ul style="list-style-type: none"> Index 0: Maximum slave telegram processing time Maximum response time from the slave to the master. Index 1: Character delay time Maximum permissible delay time between the individual characters in the Modbus frame (Modbus standard processing time for 1.5 bytes). Index2: Inter-telegram delay Maximum permissible delay time between Modbus telegrams (Modbus standard processing time for 3.5 bytes).
p2029	Fieldbus error statistics <ul style="list-style-type: none"> Displays receive errors on the fieldbus interface.
p2040	Process data monitoring time [ms] <ul style="list-style-type: none"> Setting the time to monitor the process data received. If no process data is received within this time, an appropriate message is output Factory setting: 100 ms The setting 0 ms deactivates the monitoring.

3.7.4 BACnet MS/TP

In BACnet, components and systems are considered to be black boxes which contain a number of objects. BACnet objects only define behavior outside the device. Internal functions are not determined by BACnet.

Each component is represented by a series of object types and their instances.

Each BACnet device has precisely one BACnet device object. A BACnet device is uniquely identified by an NSAP (Network Service Access Point). An NSAP consists of a network number and a MAC address. This address is BACnet-specific and must not be confused with the Ethernet MAC address.

The drive receives control commands and setpoints via service instructions from the control and transmits its status back to the control. The drive can also send telegrams automatically itself or execute services, e.g., I-Am.

3.7.4.1 Basic settings

Parameter	Description
p0015	Macro drive unit <ul style="list-style-type: none"> ● During the basic commissioning, select the value 110 "BACnet MSTP", or with firmware < 4.6 the value 21.
p2030	Fieldbus protocol selection (only with firmware < 4.6) <ul style="list-style-type: none"> ● 5: BACnet
p2021	Valid BACnet addresses: 1...127
p2020	Fieldbus baud rate <ul style="list-style-type: none"> ● 6: 9600 bps (factory setting) ● 7: 19200 bps ● 8: 38400 bps ● 10: 76800 bps
p2024	Processing times <ul style="list-style-type: none"> ● [0]: 0ms ... 10000 ms, maximum processing time (APDU timeout) Factory setting: 1000 ms ● [1...2]: No significance for BACnet
p2025	BACnet communication parameter The device object ID (p2025[0]) must be greater than 1 in the case of firmware < 4.6. <ul style="list-style-type: none"> ● [0]: 0...4194303, device object instance number Factory setting: 1 ● [1]: 1...10, Maximum info frames Factory setting: 1 For optimum performance, this value should be set to 10. ● [2]: 0...99, number of APDU retries after fault telegrams Factory setting: 3 ● [3]: 1...127, maximum master address Factory setting: 127. To optimize performance, this value should not be greater than the number of devices on the bus (including the master).
p2026	Setting the COV increment (COV = change of values) <ul style="list-style-type: none"> ● Here you can define a setting for the value changes for which an UnConfirmedCOVNotification or ConfirmedCOVNotificationresult is sent. The factory setting 0.100 means that an UnConfirmedCOVNotification or ConfirmedCOVNotification is sent if the value being considered (e.g. for a control range from 0 ... 10 V) changes by an absolute value of ≥ 0.1. Of course this only applies if previously a SubscribeCOV service was activated for the particular object instance. You can also set the COV increment using the object property "COVIncrement" of the particular analog input. ● 0...4194303.000 ● Factory setting: 0.100. ● [0]: COV increment of object instance "Analog Input 0" ● [1]: COV increment of object instance "Analog Input 1" ● [2]: COV increment of object instance "Analog Input 10" ● [3]: COV increment of object instance "Analog Input 11"
p2040	Process data monitoring time [ms]

Parameter	Description
	<ul style="list-style-type: none"> ● Setting the time to monitor the process data received. If no process data is received within this time, an appropriate message is output ● Factory setting: 100 ms ● The factory setting for communication with BACnet is possibly too low and must be increased. Adapt the value to the requirements and properties of your particular plant or system. ● The setting 0 ms deactivates the monitoring.

3.7.4.2 Fieldbus control word

r2090	BACnet	Function	Parameter
Bit 0	BV20	Command execution	p0840
Bit 1	BV27	No OFF2	p0844
Bit 2	BV28	No OFF3	p0848
Bit 3	BV26	Enable operation	p0852
Bit 4	BV26	Permit RFG enable	p1140
Bit 5	BV26	Enable RFG	p1141
Bit 6	BV26	Enable setpoint	p1142
Bit 7	BV22	Acknowledge faults	p2103
Bit 8	N/A	Reserved	-
Bit 9	N/A	Reserved	-
Bit 10	BV93	Master control by PLC	p0854
Bit 11	BV21	Inversion direction	p1113
Bit 12	N/A	Reserved	-
Bit 13	N/A	MOP setpoint higher	p1035
Bit 14	N/A	MOP setpoint lower	p1036
Bit 15	N/A	Reserved	-

The configuration workload can be reduced by leaving out values which are not required. In this case, the appropriate parameters must be set manually.

Example: If you are not using BV93, set p0854 to 1.

3.7.5 P1 FLN

Parameter	Value	Description
p0840	r2090.0	Wire ON/OFF1 to control word 1 bit 0
p0852	r2090.3	Wire the signal for "Enable operation" to control word 1 bit 3
p0971	1	Permanently save the settings in the drive
p1070	r2050.1	Connect the signal for the main setpoint to the communication interface
p2030	8	Communication protocol for P1 With this setting the drive sets parameters p2020 and p2021 as follows: <ul style="list-style-type: none"> ● p2020 = 5: Baud rate 4800 bit/s, alternative setting option for P1: p2020 = 6 (9600 bits/s) ● p2021 = 1 ... 99: Slave address (factory setting = 99).
p2051.0	r52.0	Send status word via the communication interface
p2051.1	r63.0	Send actual speed value via the communication interface

Parameter	Value	Description
p2103.0	r2090.7	Connect the first signal source for acknowledgment to the communication interface

The "Point numbers" defined in the device for communication via P1 can be found in the Operating Instructions of the CU230P-2.

3.8 Data backup on a memory card

Standard MMC cards or SD cards up to 2GB are supported. Siemens memory cards provide other functions.

▷ You require an empty memory card for the following procedure.

1. Switch off the drive power supply.
 2. If the Control Unit is connected to a computer via a USB cable, the card is identified as a bulk storage device and its use is blocked. Remove the USB cable which has been inserted.
 3. Wait until the variable speed drive is in a completely no-voltage condition and no LED on the Control Unit is lit.
 4. Insert the empty memory card into the card slot on the Control Unit.
 5. Switch on the operating voltage of the drive.
- ⇒ After the drive has been switched on, it copies the settings to the memory card.

!	<i>NOTICE</i>
	<p>If the memory card already contains another drive's settings, the drive adopts those settings.</p> <p>Data may be lost.</p> <ul style="list-style-type: none"> • Use an empty memory card.

4 Application examples

Basic commissioning is a prerequisite for the implementation of the application examples. During basic commissioning, the applications below can be parameterized directly via the macro parameter p0015. If the applications have to be set subsequently, the device must be set to commissioning state.

Example: p0010 = 1 → p0015 = 101 → p0010 = 0

4.1 Universal application

- Macro 101 "Universal application"
- Setpoint via a 0...10 V signal
- Analog setpoint can be overridden with 3 fixed speeds
- Flying restart and automatic restart activated
- Essential service mode (in the event of fire) with a fixed setpoint
- Error message: Digital output 0
- Status display: Digital output 2

Note:

In the case of the extended emergency mode, the customer can no longer lodge any claims for warranty. Extended emergency mode and the faults which arise during this mode are logged in a password-protected memory and can be read by the repair center.

Parameter	Value	Description
p731	r52.2	Signal source for terminal DO 1
p756[0]	0	Unipolar voltage input (0...10 V)
p840[0]	r20047.0	ON / OFF (OFF1)
p1000[0]	32	Speed setpoint selection
p1001[0]	800 rpm	Fixed speed setpoint 1
p1002[0]	1000 rpm	Fixed speed setpoint 2
p1003[0]	1200 rpm	Fixed speed setpoint 3
p1015[0]	1500 rpm	Fixed speed setpoint 15
p1020[0]	r722.3	Fixed speed setpoint selection Bit 0
p1021[0]	r722.4	Fixed speed setpoint selection Bit 1
p1022[0]	r722.5	Fixed speed setpoint selection Bit 2
p1071[0]	r20220	Main setpoint scaling
p1113[0]	0	Setpoint inversion
p1200[0]	1	Flying restart always active (start in setpoint direction)
p1210	26	Acknowledging all faults and restarting for an ON command
p2103[0]	0	Acknowledge faults
p2106[0]	r722.1	External fault
p3880	r722.2	ESM activation

Parameter	Value	Description
p3881	1	ESM setpoint source: Fixed setpoint 15 (p1015)
p20046[0]	r722.0	OR input I0
p20046[1]	r1025.0	OR input I1
p20048	1	OR runtime group
p20218[0]	100%	NSW input X0
p20218[1]	0	NSW input X1
p20219	r1025.0	NSW switch position I
p20221	5	NSW runtime group

4.2 Pump pressure control

- Macro 103 "Pump pressure control"
- Differential pressure regulated by integrated PID controller
- Flying restart and automatic restart activated
- Error message: Digital output 0
- Status display: Digital output 2

When selecting this application using macro 103, the technological unit remains unchanged at [%]. If necessary, adapt the unit as described in the parameter list. Select the values depending on the used sensor.

Parameter	Value	Description
p596	4	Reference variable of the technological unit
p0010	5	Parameter filter change, technological unit
p595	3	Selection of technological unit: bar
p0010	0	Parameter filter ready
p756[0]	0	Unipolar voltage input (0...10 V)
p0840	r722.0	ON / OFF (OFF1)
p1200[0]	1	Flying restart always active (start in setpoint direction)
p1210	26	Acknowledging all faults and restarting for an ON command
p2200[0]	1	Technology controller enable
p2201[0]	2 bar	Technology controller fixed value 1 Set the pressure setpoint to suit the application. This example uses a 0...4 bar sensor (e.g. QBE64).
p2253[0]	p2201	Technology controller setpoint 1
p2257	30 s	Technology controller setpoint ramp-up time
p2258	30 s	Technology controller setpoint ramp-down time
p2264[0]	r755[0]	Technology controller actual value
p2265	10 s	Technology controller actual value filter time constant
p2267	4.2 bar	Technology controller upper limit actual value
p2268	-1 bar	Technology controller lower limit actual value

Parameter	Value	Description
p2293	30 s	Technology controller ramp-up/ramp-down time

4.3 Pressure controlled supply fan + ESM fixed speed

- Macro 105 "Pressure controlled supply fan + ESM fixed speed"
- Pressure in air duct regulated by integrated PID controller
- Flying restart and automatic restart activated
- Essential service mode (in the event of fire) with fixed frequency
- Error message: Digital output 0
- Status display: Digital output 2

When selecting this application using macro 105, the technological unit remains unchanged at [%]. If necessary, adapt the unit as described in the parameter list. Select the values depending on the used sensor.

Note:
In the case of the extended emergency mode, the customer can no longer lodge any claims for warranty. Extended emergency mode and the faults which arise during this mode are logged in a password-protected memory and can be read by the repair center.

The diagram shows a terminal block with the following connections:
 - Terminals 9, 5, 6: ON/OFF and ESM Activation switches.
 - Terminals 28, 69, 2: GND, DI COM, and DI COM.
 - Terminals 4, 3: AI0- and AI0+ inputs connected to a 0-10V pressure sensor.
 - Terminals 14, 15: PTC A and PTC B inputs.
 - Terminals 12, 13: AO0+ and AO0- outputs (Speed, 0..20mA).
 - Terminals 26, 27: AO1+ and AO1- outputs (Output current, 0..20mA).
 - Terminals 19, 18: DO0 (Fault).
 - Terminals 22, 21: DO1 (Alarm).
 - Terminals 25, 24, 23: DO2 (Operation).
 - An optional switch is connected to terminals 14 and 15.

Parameter	Value	Description
p596	500	Reference variable of the technological unit
p0010	5	Parameter filter change, technological unit
p595	5	Selection of technological unit: Pa
p0010	0	Parameter filter ready
p756[0]	0	Unipolar voltage input (0...10 V)
p0840	r722.0	ON / OFF (OFF1)
p1015[0]	1350 rpm	Fixed speed setpoint 15
p1113[0]	0	Setpoint inversion
p1200[0]	1	Flying restart always active (start in setpoint direction)
p1210	26	Acknowledging all faults and restarting for an ON command
p2200[0]	1	Technology controller enable
p2201[0]	200 Pa	Technology controller fixed value 1
p2253[0]	p2201	Technology controller setpoint 1
p2257	30 s	Technology controller setpoint ramp-up time
p2258	30 s	Technology controller setpoint ramp-down time
p2264[0]	r755[0]	Technology controller actual value
p2265	10 s	Technology controller actual value filter time constant
p2267	600 Pa	Technology controller upper limit actual value
p2268	-50 Pa	Technology controller lower limit actual value
p2293	30 s	Technology controller ramp-up/ramp-down time
p3880	r722.1	ESM activation
p3881	1	ESM setpoint source: Fixed setpoint 15 (p1015)

4.4 Cooling tower fan (LG-Ni1000) + hibernation

- Macro 107 "Cooling tower LG-Ni1000 sensor + hibernation"
- Control of the cooling tower fan based on the temperature of the cooling water
- LG-Ni1000 temperature sensor on AI3
- Hibernation
- Flying restart and automatic restart activated
- Error message: Digital output 0
- Status display: Digital output 2

When selecting this application using macro 107, the technological unit remains unchanged at [%]. If necessary, adapt the unit as described in the parameter list. Select the values depending on the used sensor.

Parameter	Value	Description
p596	100	Reference variable of the technological unit
p0010	5	Parameter filter change, technological unit
p595	4	Selection of technological unit: °C
p0010	0	Parameter filter ready
p756[3]	6	LG-Ni1000 temperature sensor
p0840	r722.0	ON / OFF (OFF1)
p1200[0]	1	Flying restart always active (start in setpoint direction)
p1210	26	Acknowledging all faults and restarting for an ON command
p2200[0]	1	Technology controller enable
p2201[0]	26 °C	Technology controller fixed value 1
p2253[0]	p2201	Technology controller setpoint 1
p2257	30 s	Technology controller setpoint ramp-up time
p2258	30 s	Technology controller setpoint ramp-down time
p2264[0]	r755[3]	Technology controller actual value
p2265	10 s	Technology controller actual value filter time constant
p2267	100 °C	Technology controller upper limit actual value
p2268	-10 °C	Technology controller lower limit actual value
p2293	30 s	Technology controller ramp-up/ramp-down time
p2306	1	Technology controller fault-signal inversion
p2390[0]	50 rpm	Hibernation start speed
p2391[0]	60 s	Hibernation delay time
p2392	1 °C	Hibernation restart value with technology controller
p2398	1	Hibernation mode

4.5 Cooling tower fan (active sensor) + hibernation

- Macro 106 "Cooling tower active sensor + hibernation"
- Control of the cooling tower fan based on the temperature of the cooling water
- Temperature sensor 0...10 V on AI0
- Hibernation
- Flying restart and automatic restart activated
- Error message: Digital output 0
- Status display: Digital output 2

When selecting this application using macro 106, the technological unit remains unchanged at [%]. If necessary, adapt the unit as described in the parameter list. Select the values depending on the used sensor.

Parameter	Value	Description
p596	100	Reference variable of the technological unit
p0010	5	Parameter filter change, technological unit
p595	4	Selection of technological unit: °C
p0010	0	Parameter filter ready
p756[0]	0	Unipolar voltage input (0 V...10 V)
p0840	r722.0	ON / OFF (OFF1)
p1200[0]	1	Flying restart always active (start in setpoint direction)
p1210	26	Acknowledging all faults and restarting for an ON command
p2200[0]	1	Technology controller enable
p2201[0]	26 °C	Technology controller fixed value 1
p2253[0]	p2201	Technology controller setpoint 1
p2257	30 s	Technology controller setpoint ramp-up time
p2258	30 s	Technology controller setpoint ramp-down time
p2264[0]	r755[0]	Technology controller actual value
p2265	10 s	Technology controller actual value filter time constant
p2267	110 °C	Technology controller upper limit actual value
p2268	-10 °C	Technology controller lower limit actual value
p2293	30 s	Technology controller ramp-up/ramp-down time
p2306	1	Technology controller fault-signal inversion
p2390[0]	50 rpm	Hibernation start speed
p2391[0]	60 s	Hibernation delay time
p2392	1 °C	Hibernation restart value with technology controller
p2398	1	Hibernation mode

4.6 Stairwell pressurization (ESM)

- Macro 104 "ESM stairwell pressurization"
- Central fire alarm system starts the fan
- Essential service mode (in the event of fire) with pressurization, e.g., in a stairwell, in order to keep escape routes clear
- Flying restart and automatic restart activated
- Error message: Digital output 0
- Status display: Digital output 2

When selecting this application using macro 104, the technological unit remains unchanged at [%]. If necessary, adapt the unit as described in the parameter list. Select the values depending on the used sensor.

Note:

In the case of the extended emergency mode, the customer can no longer lodge any claims for warranty. Extended emergency mode and the faults which arise during this mode are logged in a password-protected memory and can be read by the repair center.

Parameter	Value	Description
p596	100	Reference variable of the technological unit
p0010	5	Parameter filter change, technological unit
p595	5	Selection of technological unit: Pa
p0010	0	Parameter filter ready
p1113[0]	0	Setpoint inversion
p1200[0]	1	Flying restart always active (start in setpoint direction)
p1210	26	Acknowledging all faults and restarting for an ON command
p2200[0]	1	Technology controller enable
p2201[0]	40 Pa	Technology controller fixed value 1
p2253[0]	p2201	Technology controller setpoint 1
p2264[0]	r755[0]	Technology controller actual value
p2267	120 Pa	Technology controller upper limit actual value
p2268	-10 Pa	Technology controller lower limit actual value
p3880	r722.0	ESM activation
p3881	4	ESM setpoint from the technology controller
p3884	p2201	ESM technology controller setpoint Fixed setpoint

4.7 Fixed setpoints

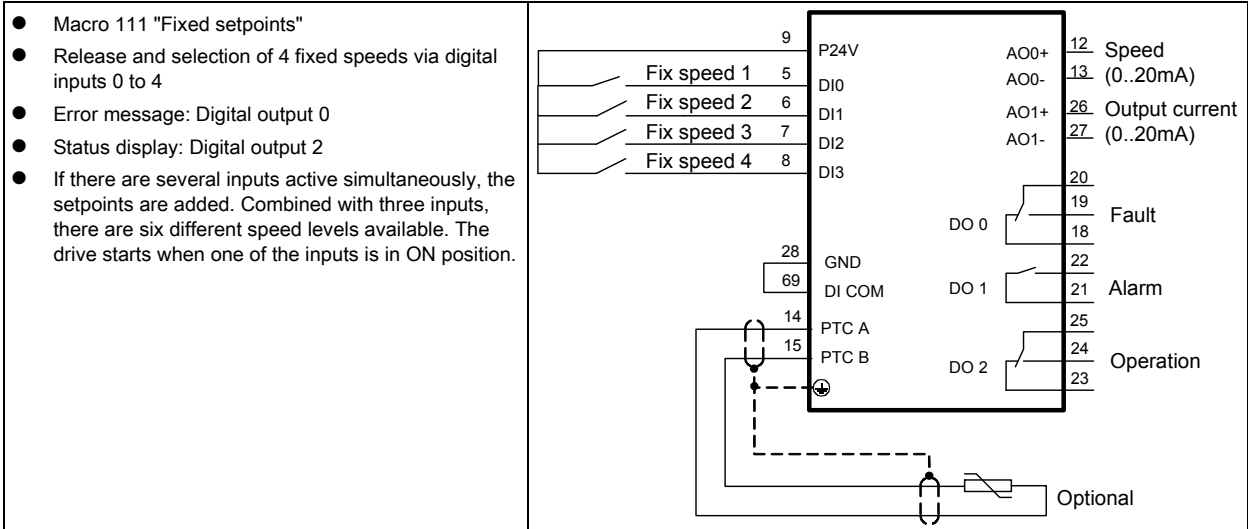

Parameter	Value	Description
p840[0]	r1025.0	ON / OFF (OFF1)
p1000[0]	3	Speed setpoint selection: Fixed speed
p1001[0]	300 rpm	Fixed speed setpoint 1
p1002[0]	600 rpm	Fixed speed setpoint 2
p1003[0]	900 rpm	Fixed speed setpoint 3
p1004[0]	1200 rpm	Fixed speed setpoint 4
p1020[0]	r722.0	BI: Fixed speed setpoint selection Bit 0
p1021[0]	r722.1	BI: Fixed speed setpoint selection Bit 1
p1022[0]	r722.2	BI: Fixed speed setpoint selection Bit 2
p1023[0]	r722.3	BI: Fixed speed setpoint selection Bit 3
p1113[0]	0	BI: Setpoint inversion
p1200[0]	1	Flying restart always active (start in setpoint direction)
p1210	26	Acknowledging all faults and restarting for an ON command
p2103[0]	0	BI: 1. Acknowledge faults

4.8 CO2 sensor, 2 PID setpoints

- Macro 112 "CO2 sensor, 2 PID setpoints"
- ON/OFF and PID setpoint selection via DI0 or DI2
- Set the fixed setpoint (50 % corresponding to the CO2 equivalent 1000 ppm)
- External alarm at DI1. The fan is stopped.
- Error message: Digital output 0
- Status display: Digital output 2
- If DI0 and DI2 are active simultaneously, the setpoints are added. The drive starts when one of the inputs is in ON position.

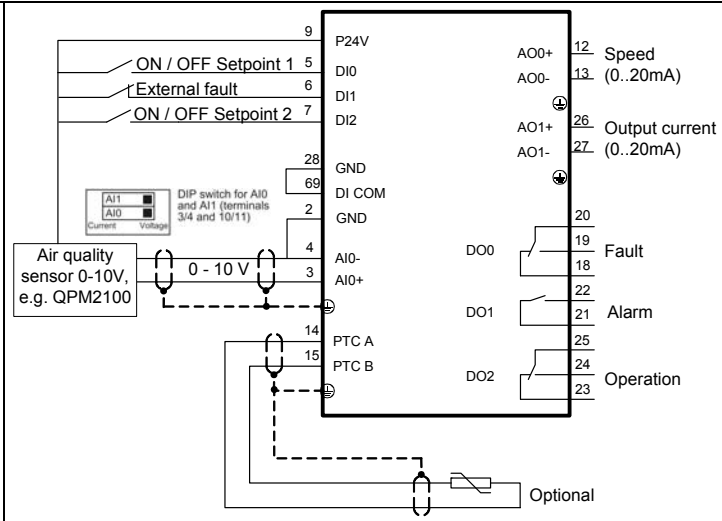

Parameter	Value	Description
p756[0]	0	Unipolar voltage input (0...10 V)
p840[0]	r2225.0	ON / OFF (OFF1)
p1113[0]	0	Setpoint inversion
p2103[0]	0	BI: 1. Acknowledge faults
p2106[0]	r722.1	External fault
p2200[0]	1	Technology controller enable
p2201[0]	50	Technology controller fixed value 1
p2203[0]	10	Technology controller fixed value 3
p2220[0]	r722.0	BI: Technology controller fixed value selection bit 0
p2222[0]	r722.2	BI: Technology controller fixed value selection bit 2
p2253[0]	r2224	Technology controller setpoint 1
p2264[0]	r755[0]	Technology controller actual value
p2267	120%	Technology controller upper limit actual value
p2268	-10%	Technology controller lower limit actual value
p2306	1	Technology controller fault-signal inversion

4.9 Temperature-dependent pressure setpoint

- Macro 113 "Temperature-dependent pressure setpoint"
- Pressure control setpoint dependent on outside temperature and limited between 20% and 50%

- LG-Ni1000 temperature sensor on AI2
- Pressure sensor 0...10 V on AI0
- Flying restart and automatic restart activated
- Error message: Digital output 0
- Status display: Digital output 2

Parameter	Value	Description
p756[2]	6	AI2: LG-Ni1000 temperature sensor
p757[2]	-20 °C	AI2 characteristic x1
p758[2]	20 %	AI2 characteristic y1
p759[2]	5 °C	AI2 characteristic x2
p760[2]	50 %	AI2 characteristic y2
p840[0]	r722.0	ON / OFF (OFF1)
p1200[0]	1	Flying restart always active (start in setpoint direction)
p1210	26	Acknowledging all faults and restarting for an ON command
p2200[0]	1	Technology controller enable
p2253[0]	r20231	Technology controller setpoint
p2257	30 s	Technology controller setpoint ramp-up time
p2258	30 s	Technology controller setpoint ramp-down time
p2264[0]	r755[0]	Technology controller actual value from AI0
p2265	10 s	Technology controller actual value filter time constant
p2267	120 %	Technology controller upper limit actual value
p2268	-10 %	Technology controller lower limit actual value
p2293	30 s	Technology controller ramp-up/ramp-down time
p20228	r755[2]	Setpoint limiting
p20229	0.5	Upper limit setpoint limiting 50%
p20230	0.2	Lower limit setpoint limiting 20%
p20234	5	Runtime group setpoint limiting

5 Service and maintenance

The Power Module primarily consists of maintenance-free, electronic components. Some of the mechanical parts are wearing parts and have to be replaced at certain intervals.

The following maintenance procedures essentially arise:

1. Regularly remove dirt and impurities in order to ensure that cooling works effectively.
2. Regularly check that the fans are working properly.
3. Ensure that the cabinet's ventilation slots are not blocked.
4. Regularly check that the cables and screw terminals are correctly fixed in place.
5. If necessary, re-tighten the fastenings for the cables and screw terminals.
6. Check the cables and screw terminals regularly for damage.
7. Replace any defective parts immediately.
8. Replace wearing parts which are worn.

The actual maintenance intervals depend on the installation and operating conditions.



Siemens offers its customers tailor-made maintenance contracts. For more information, please contact your local Siemens representative.

5.1 Service life of the fan

The average service life of fans is 40 000 hours. In practice, the service life may differ from this value, in particular in dusty environments.

The fan must be replaced in good time in order to ensure that the drive remains ready for operation.

Replacing the fan

Information about replacing the fan can be found in the following manuals:

- Hardware Installation Manual for Power Module PM230 IP55/UL Type 12 (A5E02923635A AA)
- Hardware Installation Manual for Power Module PM230 IP20 (A5E03448282A AA)

The fans are available as spare parts through your local Siemens branch office.

6 Fault rectification

The variable speed drive uses the following means to display faults and operating states:

- The LEDs on the front indicate the most important operating states.
- The drive displays alarms and faults via the fieldbus, the terminal strip, a connected operator panel, or via the STARTER software.



Alarms and faults have a unique number.

6.1 Restart after a crash

The drive can adopt the following state, for example, by loading a defective file from the memory card:

- ▷ The motor is switched off.
 - ▷ You cannot communicate with the drive, either via the operator panel or other interfaces.
1. Remove the memory card if one is inserted in the converter.
 2. Switch off the drive power supply.
 3. Wait until all LEDs on the drive are extinguished.
 4. Switch on the power supply again.
 5. Repeat steps 2 to 4 until fault code F01018 is output.
 6. Repeat steps 2 to 4 once again until fault code F01018 is output.
- ⇒ The drive adopts the factory settings.
- Repeat the commissioning process.

6.2 Displayed operating states

The Control Unit has two LEDs which indicate the operating state of the drive:

- LED RDY = Ready
- LED BF = Bus Fault

The LED RDY (Ready) is temporarily orange after the power supply voltage is switched on. As soon as the color of the LED RDY changes to either red or green, the LEDs signal the drive state.

In addition to the signal states "On" and "Off" there are two different flashing frequencies:

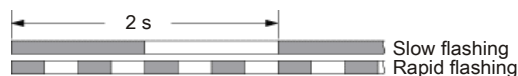

LED		Description
RDY	BF	
Green - On	---	No fault
Green - Slow	---	Commissioning or reset to factory settings
Red - Fast	---	No fault

LED		Description
RDY	BF	
Red – Fast	Red – Fast	Incorrect memory card
Green - On	On	Receive process data
Green - On	Red – Slow	Bus active - no process data
Green - On	Red – Fast	No bus activity

6.3 Alarms and faults

This is only an extract. The complete list of alarms and faults can be found in List Manual CU230P (A5E02297932A AE).

Alarms

Number	Cause	Solution
A01028	Configuration error	Parameterization on the memory card has been created with a different type of module (order number, MLFB). <ul style="list-style-type: none"> ● Check the module parameters and recommission if necessary.
A01098	The power supply for the Control Unit was interrupted for a longer period.	<ul style="list-style-type: none"> ● Set the date and time of day of the real-time clock: p8400 (RTC time), p8401 (RTC date) ● Deactivate the alarm: p8405 = 0.
A01590	Motor maintenance interval lapsed	<ul style="list-style-type: none"> ● Carry out maintenance and reset the maintenance interval (p0651).
A01900	PROFIBUS: Configuration telegram faulty	A PROFIBUS master is attempting to establish a connection with a faulty configuration telegram. <ul style="list-style-type: none"> ● Check the bus configuration on the master and slave side.
A01910 F01910	Setpoint timeout: p2040 ≠ 0 ms and one of the following causes: <ul style="list-style-type: none"> ● The bus connection is interrupted ● The MODBUS master is switched off ● Communications error (CRC, parity bit, logical error) 	<ul style="list-style-type: none"> ● Establish the bus connection and switch on the communication partners. ● Possibly adapt p2040. ● Set the PROFIBUS master to RUN.
A01920	PROFIBUS: Cyclic connection interrupt	The cyclic connection to the PROFIBUS master is interrupted. <ul style="list-style-type: none"> ● Establish the PROFIBUS connection and activate the PROFIBUS master with cyclic operation.
A03520	Temperature sensor fault	<ul style="list-style-type: none"> ● Check that the sensor is correctly connected.
A05000 A05001 A05002 A05004 A05006	Power Module overtemperature	<ul style="list-style-type: none"> ● Check that the ambient temperature is within the defined limit values. ● Check that the load conditions and duty cycle are appropriately dimensioned. ● Check whether there has been a cooling system failure.
A07012	I2t motor model overtemperature	<ul style="list-style-type: none"> ● Reduce the motor load. ● Check the ambient temperature and the motor ventilation. ● Check the thermal time constant p0611. ● Check overtemperature fault threshold p0605.
A07015	Motor temperature sensor alarm	<ul style="list-style-type: none"> ● Check that the sensor is correctly connected. ● Check the parameter assignment (p0601).
A07321	Automatic restart active	Automatic restart is active. During voltage recovery or when remedying the causes of pending faults, the drive is automatically switched back on. <ul style="list-style-type: none"> ● Block the automatic restart (p1210 = 0). ● Abort the restart process by removing the switch-on command (p8040).

Number	Cause	Solution
A07400	DC-link voltage maximum controller (VDC_max controller) active	If intervention by the controller is not desirable: <ul style="list-style-type: none"> ● Increase the ramp-down times. ● Deactivate the VDC_max controller (p1240 = 0 for vector control, p1280 = 0 for V/f control).
A07409	V/f control, current limiting controller active	The alarm is automatically canceled after one of the following measures: <ul style="list-style-type: none"> ● Increase the current limit (p0640). ● Reduce the load. ● Reduce the up ramps for the setpoint speed.
A07805	Drive: Power unit overload I2t	<ul style="list-style-type: none"> ● Reduce the continuous load. ● Adapt the duty cycle. ● Check the assignment of rated currents of motor and power unit.
A07850 A07851 A07852	External alarm 1 ... 3	Parameters p2112, p2116 and p2117 determine the signal sources for the external alarm 1... 3. <ul style="list-style-type: none"> ● The drive receives an alarm from an external source. Rectify the cause of this alarm.
A07903	Motor speed deviation	<ul style="list-style-type: none"> ● Increase p2163 or p2166. ● Increase the torque, current and power limits.
A07910	Motor overtemperature	<ul style="list-style-type: none"> ● Check the motor load. ● Check the ambient temperature and the motor ventilation. ● Check the KTY84 sensor. ● Check the overtemperatures of the thermal model (p0626 ... p0628).
A07920 F07923	Torque/speed too low	The torque deviates from the torque/speed envelope curve. <ul style="list-style-type: none"> ● Check the connection between the motor and load. ● Adjust the settings according to the load.
A07921 F07924	Torque/speed too high	
A07922	Torque/speed out of tolerance	
A07927	DC braking active	The alarm disappears after DC braking.
A07980	Rotary measurement activated	The alarm disappears after optimization of the speed controller.
A07981	Rotating measurement: No enable signals	<ul style="list-style-type: none"> ● Acknowledge pending faults. ● Create enable signals which are missing.
A07991	Motor data identification activated	The alarm disappears after motor data identification.
A30049	Internal fan defective	<ul style="list-style-type: none"> ● Check the internal fan and replace it, if necessary.
A30502	DC link overvoltage	<ul style="list-style-type: none"> ● Check the device supply voltage (p0210). ● Check the dimensions of the line reactor.
A30920	Temperature sensor fault	<ul style="list-style-type: none"> ● Check that the sensor is correctly connected.

Faults

Number	Cause	Solution
F01000	Software fault in CU	<ul style="list-style-type: none"> ● Replace the CU.
F01001	FloatingPoint exception	<ul style="list-style-type: none"> ● Switch the CU off and on again.
F01015	Software fault in CU	<ul style="list-style-type: none"> ● Update the firmware ● Contact Technical Support. ● Replace the CU.
F01018	Power-up aborted more than once	<ol style="list-style-type: none"> 1. Switch the module off and on again. 2. After this fault has been output, the module is booted with the factory settings.

Number	Cause	Solution
		3. Recommission the drive.
F01033	Unit switchover: Reference parameter value invalid	<ul style="list-style-type: none"> ● Set the value of the reference parameter not equal to 0.0 (p0304, p0305, p0310, p0596, p2000, p2001, p2002, p2003, r2004).
F01034	Unit switchover: Calculation of the parameter values after reference value change unsuccessful	<ul style="list-style-type: none"> ● Select the value of the reference parameter so that the parameters involved can be calculated in the representation (p0304, p0305, p0310, p0596, p2000, p2001, p2002, p2003, r2004).
F01040	Parameters must be saved	<ul style="list-style-type: none"> ● Save the parameters (p0971). ● Switch the CU off and on again.
F01044	Fault loading the data from the memory card	<ul style="list-style-type: none"> ● Replace the memory card of the CU.
F01105	Insufficient memory	<ul style="list-style-type: none"> ● Reduce the number of data records.
F01122	Frequency at the probe input too high	<ul style="list-style-type: none"> ● Reduce the frequency of the pulses at the measuring input.
F01205	Time slice overflow	<ul style="list-style-type: none"> ● Contact Technical Support.
F01250	CU hardware fault	<ul style="list-style-type: none"> ● Replace the CU.
F01512	No scaling	<p>An attempt has been made to establish a conversion factor for scaling which is not present.</p> <ul style="list-style-type: none"> ● Apply scaling or check the transfer value.
F01662	CU hardware fault	<ul style="list-style-type: none"> ● Switch the CU off and on again. ● Update the firmware. ● Contact Technical Support.
A01910 F01910	<p>Setpoint timeout: p2040 ≠ 0 ms and one of the following causes:</p> <ul style="list-style-type: none"> ● The bus connection is interrupted ● The MODBUS master is switched off ● Communications error (CRC, parity bit, logical error) 	<ul style="list-style-type: none"> ● Establish the bus connection and switch on the communication partners. ● Possibly adapt p2040. ● Set the PROFIBUS master to RUN.
F03505	Analog input, wire break	<ul style="list-style-type: none"> ● Check the connection with the signal source for interruptions. ● Check the level of the signal which is fed in. <p>The input current measured by the analog input can be read in r0752.</p>
F06310	Supply voltage (p0210) incorrectly parameterized	<ul style="list-style-type: none"> ● Check the supply voltage and change the parameter (p0210), if necessary. ● Check the line voltage.
F07011	Motor overtemperature	<ul style="list-style-type: none"> ● Reduce the motor load. ● Check the ambient temperature and the motor ventilation. ● Check the wiring and the connection of the sensor.
F07016	Motor temperature sensor fault	<ul style="list-style-type: none"> ● Check that the sensor is correctly connected. ● Check the parameter assignment (p0601). ● Switch off the temperature sensor error (p0607 = 0).
F07086 F07088	Unit switchover: Parameter limit violation	<ul style="list-style-type: none"> ● Check the adapted parameter value and correct it, if necessary.
F07320	Automatic restart aborted	<ul style="list-style-type: none"> ● Increase the number of restart attempts (p1211). The actual number of start attempts is shown in r1214. ● Increase the waiting time in p1212 or the monitoring time in p1213. ● Apply the ON command (p0840). ● Increase the monitoring time of the power unit or disable the monitoring time (p0857). ● Reduce the waiting time for resetting the fault counter p1213[1] so that fewer faults are registered in the time interval.
F07330	Search current measured too low	<ul style="list-style-type: none"> ● Increase the search current (p1202).

Number	Cause	Solution
		<ul style="list-style-type: none"> ● Check that the motor is correctly connected.
F07426	Technology controller actual value limited	<p>The actual value for the technology controller which is interconnected via connector input p2264 has reached a limit.</p> <ul style="list-style-type: none"> ● Adjust the limits to the signal level (p2267, p2268). ● Check the actual value (p2264).
F07801	Motor overcurrent	<p>The permissible motor limit current has been exceeded.</p> <ul style="list-style-type: none"> ● Check the current limits (p0640). ● Vector control: Check the settings for the current controller (p1715, p1717). ● V/f control: Check the settings for the current limiting controller (p1340...p1346). ● Increase the up ramp (p1120) or reduce the load. ● Check the motor and the motor cables for short-circuits or ground faults. ● Check the motor for star-delta connection and rating plate parameterization. ● Check the combination of the power unit and motor. ● Select the flying restart function (p1200) if switched to rotating motor.
F07806	Regenerative power limit exceeded	<ul style="list-style-type: none"> ● Increase the down ramp. ● Reduce the driving load. ● Use a power unit with a higher regenerative feedback capability. ● For vector controls, the regenerative power limit in p1531 can be reduced until the fault is no longer activated.
F07807	Short circuit detected	<ul style="list-style-type: none"> ● Check the drive connection on the motor side for any phase-to-phase short-circuit. ● Ensure that no line and motor cables have been accidentally mixed up.
F07860 F07861 F07862	External fault 1...3	<ul style="list-style-type: none"> ● The drive receives an alarm from an external source. Rectify the causes of this fault.
F07900	Motor blocked	<ul style="list-style-type: none"> ● Check that the motor can run freely. ● Check the torque limits (r1538 and r1539). ● Check the parameters of the "Motor blocked" message (p2175, p2177).
F07901	Motor overspeed	<ul style="list-style-type: none"> ● Activate precontrol of the speed limiting controller (p1401 bit 7 = 1). ● Increase the hysteresis for the overspeed signal (p2162).
F07902	Motor stalled	<ul style="list-style-type: none"> ● Check whether the motor data has been set correctly and perform a motor identification. ● Check the current limits (p0640, r0067, r0289). If the current limits are too low, the drive cannot be magnetized. ● Check whether motor cables are disconnected during operation.
A07920 F07923	Torque/speed too low	<p>The torque deviates from the torque/speed envelope curve.</p> <ul style="list-style-type: none"> ● Check the connection between the motor and load. ● Adjust the settings according to the load.
A07921 F07924	Torque/speed too high	
A07929	No motor detected	<p>The magnitude of the current following enabling of the drive pulses is so small that no motor is detected.</p> <ul style="list-style-type: none"> ● Check the motor cables, contactors and switches. ● Reduce the threshold value (p2179, e.g. with synchronous motors) ● Check the voltage boost of the V/f control (p1310) ● Carry out a measurement at standstill in order to set the stator resistance (p0350).
A07994	Motor data identification not carried out	<p>The "Vector control" mode is set but motor data identification has not yet been carried out.</p> <ul style="list-style-type: none"> ● Carry out motor data identification (see p1900). ● Set the parameters for the "V/f control" (p1300 < 20).
F30001	Power unit: Overcurrent	Check the following settings and components:

Number	Cause	Solution
		<ul style="list-style-type: none"> ● Motor data. Perform commissioning, if necessary. ● Motor connection method (Y / Δ). ● V/f operation, the assignment of the rated currents of the motor and power unit. ● Line quality. ● The line commutating reactor must be connected properly. ● Power cable connections. ● Power cables for short-circuit or ground fault ● Power cable length ● Line phases If the fault is still present: <ul style="list-style-type: none"> ● V/f operation: Increase the up ramp. ● Reduce the load. ● Replace the power unit.
F30002	Power unit: DC-link voltage overvoltage	<ul style="list-style-type: none"> ● Increase the ramp-down time (p1121). ● Set the rounding times (p1130, p1136). ● Activate the DC link voltage controller (p1240, p1280). ● Check the line voltage (p0210). ● Check the line phases.
F30003	Power unit: DC-link voltage undervoltage	<ul style="list-style-type: none"> ● Check the line voltage (p0210). ● Check the line phases.
F30004	Drive overtemperature	<ul style="list-style-type: none"> ● Check whether the drive fan is running. ● Check the ambient temperature. ● Check whether the motor is overloaded. ● Reduce the pulse frequency.
F30005	I2t drive overload	<ul style="list-style-type: none"> ● Check the rated currents of the motor and Power Module. ● Reduce current limit p0640. ● When operating with V/f characteristic: Reduce p1341.
F30011	Line phase failure	<ul style="list-style-type: none"> ● Check the drive's input fuses. ● Check the motor cables.
F30015	Motor cable phase failure	<ul style="list-style-type: none"> ● Check the motor cables. ● Increase the ramp-up or ramp-down time (p1120).
F30021	Ground fault	<ul style="list-style-type: none"> ● Check the power cable connections. ● Check the motor. ● Check the current transducer. ● Check the cables and contacts of the brake connection (a wire might be broken).
F30022	Power Module: UCE monitoring	<ul style="list-style-type: none"> ● Check the Power Module. ● Replace the Power Module, if necessary.
F30027	Time monitoring for DC link pre-charging	<ul style="list-style-type: none"> ● Check the supply voltage at the input terminals. ● Check the line voltage setting (p0210).
F30035	Overtemperature, intake air	<ul style="list-style-type: none"> ● Check whether the fan is running.
F30036	Overtemperature, inside area	<ul style="list-style-type: none"> ● Check the fan elements. ● Check the ambient temperature.
F30037	Rectifier overtemperature	<ul style="list-style-type: none"> ● Check whether the fan is running. ● Check the fan elements. ● Check the ambient temperature. ● Check the motor load. ● Check the line phases.

Number	Cause	Solution
F30052	Incorrect Power Module data	<ul style="list-style-type: none"> ● Replace the Power Module. ● Update the CU firmware.
F30662	CU hardware fault	<ul style="list-style-type: none"> ● Switch the CU off and on again. ● Update the firmware. ● Contact Technical Support.
F30664	CU power up aborted	<ul style="list-style-type: none"> ● Switch the CU off and on again. ● Update the firmware. ● Contact Technical Support.
F30850	Software fault in Power Module	<ul style="list-style-type: none"> ● Replace the Power Module. ● Contact Technical Support.
F30059	Internal fan defective	<ul style="list-style-type: none"> ● Check the internal fan and replace it, if necessary.

6.4 Hardware diagnostics

	<p>⚠ DANGER</p>
	<p>Electrical voltage can result in death or serious injury.</p> <ul style="list-style-type: none"> ● Tests may only be carried out on a drive by personnel who are trained in working with voltages of up to 600 V AC and 1800 V DC. ● Ensure that the drive is grounded correctly. ● Switch off the supply line to the drive before carrying out work on the drive or on any of its parts. ● Isolate the power supply to the drive before carrying out work on the drive or on any of its parts. ● After switching off the power supply, wait at least 5 minutes for the capacitor to discharge completely.

The following devices are required for conducting the tests:

1. Digital multimeter, preferably with a scale for PWM voltage (e.g., Fluke 87)
2. PC with the latest version of STARTER
3. IOP (Intelligent Operator Panel)

6.4.1 Tests without a power supply

	<p>⚠ CAUTION</p>
	<p>Risk of electric current</p> <p>If the terminals are not accessible externally, do not open the device because you will be exposed to a great risk and this will invalidate the warranty.</p> <ul style="list-style-type: none"> ● In this case, contact your local Siemens branch office.

Preliminary tests

Check/Test	Description	OK
Switch off the power supply	<ul style="list-style-type: none"> Ensure that the drive is disconnected from the line supply. 	
Securing	<ul style="list-style-type: none"> Secure the drive so that it cannot be switched on again. 	
Ensure that there is no voltage present at the drive.	<ul style="list-style-type: none"> Measure the voltage between L1/L2 and L3. Make sure that the system is completely de-energized. 	
Damage caused by external factors	<ul style="list-style-type: none"> Check whether parts are damaged, for example by corrosion, paint, moisture, oil, dust, powder etc. 	
Electrical damage	<ul style="list-style-type: none"> Look for evidence of flashovers or burning at the power terminals. These are caused by connecting the power cables incorrectly. 	
Interference by customers	<ul style="list-style-type: none"> Examine the drive for signs that customers have attempted to repair the drive themselves. 	
Fuses	<ul style="list-style-type: none"> Check the sizes of the fuses. Make sure that they are not "open". 	

Static check on the drive

The following checks are standard tests. These tests can be performed on most drives which are designed in accordance with the conventional principle "Rectifier – DC bus – IGBT bridge". The customer is not meant to use the DC bus terminals on the PM230/G120P. However, the terminals are accessible on some models.



Set the multimeter to "Diode" in order to measure the terminals.

The following tables show where to connect the test cable on the drive and what test result you are likely to receive.

Rectifier tests			
Positive measuring point	Negative measuring point	Expected result	OK
L1	DC+	Diode aperture – typically 0.3 – 0.5V	
L2	DC+	Diode aperture – typically 0.3 – 0.5V	
L3	DC+	Diode aperture – typically 0.3 – 0.5V	
L1	DC	Diode block – OL/High impedance	
L2	DC	Diode block – OL/High impedance	
L3	DC	Diode block – OL/High impedance	
DC+	L1	Diode block – OL/High impedance	
DC+	L2	Diode block – OL/High impedance	
DC+	L3	Diode block – OL/High impedance	
DC	L1	Diode aperture – typically 0.3...0.5 V	
DC	L2	Diode aperture – typically 0.3...0.5 V	
DC	L3	Diode aperture – typically 0.3...0.5 V	

IGBT bridge test			
Positive measuring point	Negative measuring point	Expected result	OK
U	DC+	Diode aperture – typically 0.3...0.5 V	
V	DC+	Diode aperture – typically 0.3...0.5 V	
W	DC+	Diode aperture – typically 0.3...0.5 V	
U	DC	Diode block – OL/High impedance	
V	DC	Diode block – OL/High impedance	
W	DC	Diode block – OL/High impedance	

Procedure

- ▷ If the drive fails any of these tests:
 - Remove the power unit in order to replace or repair it.
- ▷ If a short-circuit occurs at the input rectifiers or at components of the IGBT bridge:
 - Check the state of fuses in the supply line, of contactors, disconnectors or of the motor itself.



Please be aware that an apparently open circuit can also occur following a component short-circuit and the resulting strong flow of current.

6.4.2 Power test

	<p>⚠ DANGER</p>
	<p>Electrical current and moving parts when commissioning equipment or systems</p> <ul style="list-style-type: none"> ● Before commissioning the drive, secure the system, for example by cordoning it off. ● Ensure that all the covers are applied to the drive, and that no live parts are accessible.



Wherever possible, connect measuring equipment before switching the drive on.

Check/Test	Description	OK
Measuring DC bus voltage	The measured DC voltage at the terminals (not available on all types) should correspond to the peak-to-peak voltage of the applied AC input (typically 580 V).	
DC bus voltage – from parameter r0070	r0070 is the measured DC bus voltage of the drive. This does not function below 200 V DC. The parameter has access level 3.	
DC bus voltage – from parameter r0026	r0026 is the measured, smoothed DC bus voltage of the drive. This does not function below 200 V DC. The parameter has access level 2.	

Check/Test	Description	OK
Fan	<ul style="list-style-type: none"> Check the incoming supply. If you can hear the sounds of the fan, the incoming supply is okay. 	
10 V	<ul style="list-style-type: none"> Check the incoming supply between terminals T35 and T36. 10 V are okay. 	
24 V	<ul style="list-style-type: none"> Check the incoming supply between terminals T9 and T28. 24 V are okay. 	

Procedure

- ▷ If all the tests have been passed apart from the fan test:
 - Replace the fan as indicated in the Hardware Installation Manual.
- ▷ If the fans are not working and the DC bus monitor shows 0, the power unit may possibly be defective. The monitored DC bus signals indicate that the microcontroller system for the drive is working properly. A problem in the supply voltage could be the result of incorrect wiring by the customer. If the problem persists:
 - Remove the wiring and check it once again.
- ▷ If the problem persists and the fan and the DC monitor are working properly, the cause of the problem may reside in the control unit.
 - Check the control unit.

!	NOTICE
	Be aware that the defect may cause damage to both parts of the drive.

6.4.3 Function test

- Perform the preliminary tests set out in the table below without the motor connected.

Check/Test	Description	OK
MANUAL operation	<ol style="list-style-type: none"> Monitor the motor output terminals using a suitable multimeter which is also capable of measuring PWM voltages. Use an IOP and select "Manual" mode via the appropriate button. Stop the drive with the I and O buttons. Start the drive. Once the test has been completed, reset the operating mode to "Auto". <p>You can change the output voltage or the speed with the button on the IOP. "Backwards" can be enabled using the "Control" menu on the IOP.</p>	
AUTO mode	<ol style="list-style-type: none"> Monitor the motor output terminals using a suitable multimeter which is also capable of measuring PWM voltages. Ask a competent operator to isolate the drive. Ensure that all stop/start functions, etc. are working properly. <p>The output voltage rises in accordance with the requested higher speed until a maximum close to the line voltage is reached unless this value is limited by the system settings. All three phases should exhibit a similar value.</p>	

IOP diagnostics

Test the wiring carried out by the customer via the following checks. Ensure that the correct signals reach the drive.

If this reveals that the control wiring is correct, either the drive is defective or the configuration is incorrect.

Check/Test	Description	OK
IOP diagnostics – digital inputs	<ol style="list-style-type: none"> 1. Switch the digital signals in the menu "Diagnostics / I/O state / Digital inputs state". 2. Watch the display on the IOP. 	
IOP diagnostics – digital outputs	<ol style="list-style-type: none"> 1. Change the drive state in the menu "Diagnostics / I/O state / Digital outputs state". 2. Watch the display on the IOP. 	
IOP diagnostics – analog inputs	<ol style="list-style-type: none"> 1. Change the analog signal value in the menu "Diagnostics / I/O state / Analog inputs state". 2. Watch the display on the IOP. 	
IOP diagnostics – analog outputs	<ol style="list-style-type: none"> 1. Change the drive state in the menu "Diagnostics / I/O state / Digital outputs state". 2. Watch the display on the IOP. 	

IOP simulation

Perform the following checks to test the inputs of the drive. Wiring errors by the customer may be discovered, and you may also discover that the drive has been incorrectly set.

Check/Test	Description	OK
IOP I/O simulation	<ul style="list-style-type: none"> ● Select the "Diagnostics / I/O simulation" menu. ● If the drive output responds to the simulation steps performed, this indicates that the drive is probably working properly but that the wiring is incorrect. 	

- ▷ If all the checks reveal that both the drive and the wiring are okay:
 - Reset the drive to the factory settings. See Resetting to factory settings [→ 26].
- ⇒ This will allow you to tell whether the drive has been incorrectly configured.

!	<p>NOTICE</p> <p>Once the drive has been reset to its factory settings, it must be recommissioned. Have a copy of the customer's work settings to hand before resetting the drive to its factory settings.</p>
----------	---

Further procedure

- ▷ If, having conducted all the measures, you are still unable to commission the drive, it may be defective.
 1. Replace the control unit/power unit.
 2. Contact Technical Support.

7 Appendix

7.1 Commissioning report

Parameter	Function	Factory setting	Setting
P0970	Restoring the factory setting	-	
P1300	Control type	2 (V/f parabolic)	
P0100	Motor standard	0 (IEC motor)	
P0304	Rated motor voltage [V]		
P0305	Rated motor current [A]		
P0307	Motor power [kW]		
P0311	Rated motor speed [rpm]		
P1900	Motor data identification selection	0	
P0015	Macro parameter	12	
P1080	Minimum speed [rpm]	0	
P1120	Ramp-up time [s]	10	
P1121	Ramp-down time [s]	30	
P0601	Motor temperature sensor	0 (no sensor)	
P0731 (0)	Digital output function 0	52.3 (Fault)	
P0732 (0)	Digital output function 1	52.7 (Alarm)	
P0732 (0)	Digital output function 2	52.3 (Operation)	
P0757 (0)	x1 value for ADC scaling [V / mA]	0	
P0758 (0)	y1 value for ADC scaling [%]	0	
P1082	Maximum speed [rpm]	1500	
P1200	Flying restart operating mode	0 (flying restart inactive)	
P1210	Automatic Restart	0 (disabled)	
P1211	No. of start attempts	3	
P1212	Time until the first restart [s]	1	
P1213[0]	Monitoring time for restart [s]	60	
P1213[1]	Time to reset the start counter [s]	0	
P1240	Configuration of the Vdc controller	1	
P1820	Reverse output phase sequence	0	
P2000	Reference speed [rpm]	1500	

7.2 Available documentation

Title	Description	Source/Document ID
Getting Started	Design, installation, commissioning and troubleshooting the SINAMICS G120P.	A5E03653438A AA
Getting Started Guide Power Module PM230 Hardware IP55	Quick guide with dimensions and design and installation notes.	A5E02923634A
Getting Started Guide Power Module PM230 Hardware IP20	Quick guide with dimensions and design and installation notes.	A5E03460238A
Hardware Installation	Guide with all the information needed to	A5E02923635A AA

Title	Description	Source/Document ID
Manual Power Module PM230 Hardware IP55	install, mount, connect, and service SINAMICS G120P systems.	
Hardware Installation Manual Power Module PM230 Hardware IP20	Guide with all the information needed to install, mount, connect, and service SINAMICS G120P systems.	A5E03448282A AA
Application examples	See link for application examples and information on use of variable speed drives	http://support.automation.siemens.com/WW/view/de/20208582/136000
General product information	See link for detailed information and support tools for the variable speed drives	http://www.siemens.com/g120p
Operating Instructions Control Unit	Guide for installation engineers, commissioners, and operators on Control Unit CU230P-2	A5E02430659A AF
List Manual Control Unit	Manual with list information including parameters and error codes.	A5E02297932A AF
Desigo	Information on commissioning and integrating into Desigo systems including parameter settings	CM110576
PICS	SINAMICS BACnet Protocol Implementation Conformance Statement	CM2Y5111
Data sheet: system components	Data sheet with general information on the IOP and BOP-2 devices and the blanking cover	CM1N5116de
SINAMICS G120P operation in the event of a fire	Use of Essential Service Mode (ESM)	Entry ID: 63969509
Bundle sheet	Installation instructions FSA to FSC	A5E03879678 Index A
Line filters	Installation instructions FSA to FSC	A5E03879697A AB
Line filters	Installation instructions FSD to FSF	A5E31327192A AB

Issued by
Siemens Switzerland Ltd
Infrastructure & Cities Sector
Building Technologies Division
International Headquarters
Gubelstrasse 22
CH-6301 Zug
Tel. +41 41-724 24 24
www.siemens.com/buildingtechnologies

© 2012-2014 Copyright Siemens Switzerland Ltd
Technical specifications and availability subject to change without notice.