



## Differential Pressure Sensor

**QBE3000-D..**  
**QBE3100-D..**

for neutral and mildly corrosive liquids and gases

---

**Differential pressure sensor, suitable for gases or liquids, for the measurement of pressure differentials in HVAC systems.**

- Measuring system based on ceramic lever technology
- Robust construction for highly reliable operation
- For neutral and mildly corrosive liquids and gases
- Supply voltage AC 24 V / DC 18-33 V or DC 11-33 V
- DC 0...10 V output signal or DC 4-20 mA
- Male-threaded G<sup>1/8</sup>" connection
- Delivery includes 2 screwed fittings for copper pipes, 6 mm diameter

---

### Use

The differential pressure sensor is particularly suitable for use in HVAC systems for continuous monitoring of the level or flow rate of neutral or mildly corrosive gases or liquids.

The sensor can be used as:

- Control sensor
- Measured value transmitter for building automation and control systems

## Type summary

---

Type	Article number	Pressure range		Output signal
		[bar]	[MPa]	
QBE3000-D1	S55720-S173	0-1	0-0.10	DC 0-10 V
QBE3000-D1.6	S55720-S174	0-1.6	0-0.16	DC 0-10 V
QBE3000-D2.5	S55720-S175	0-2.5	0-0.25	DC 0-10 V
QBE3000-D4	S55720-S176	0-4	0-0.40	DC 0-10 V
QBE3000-D6	S55720-S186	0-6	0-0.60	DC 0-10 V
QBE3000-D10	S55720-S177	0-10	0-1	DC 0-10 V
QBE3000-D16	S55720-S178	0-16	0-1.6	DC 0-10 V
QBE3100-D1	S55720-S179	0-1	0-0.10	DC 4-20 mA
QBE3100-D1.6	S55720-S180	0-1.6	0-0.16	DC 4-20 mA
QBE3100-D2.5	S55720-S181	0-2.5	0-0.25	DC 4-20 mA
QBE3100-D4	S55720-S182	0-4	0-0.40	DC 4-20 mA
QBE3100-D6	S55720-S187	0-6	0-0.60	DC 4-20 mA
QBE3100-D10	S55720-S183	0-10	0-1	DC 4-20 mA
QBE3100-D16	S55720-S184	0-16	0-1.6	DC 4-20 mA

## Ordering and delivery

---

When ordering, please specify the quantity, product name and type code.

*Example: 1 differential pressure sensor QBE3000-D1*

A suitable fixing bracket is supplied with the sensor.

Any accessories required must be ordered separately.

## Compatibility

---

Differential pressure sensors can be used in conjunction with all devices or systems capable of processing the DC 0-10 V or DC 4-20 mA output signal.

## Technology

---

The pressure to be monitored acts on a ceramic sensor element. The ceramic element has the following significant advantages

- Very low susceptibility to temperature
- Resistance to high temperature
- No mechanical ageing or creepage

The sensor signal is linearised, temperature-compensated and amplified by the sensor electronics.

## Mechanical design

---

The differential pressure sensor comprises the following:

- Sensor cover with DIN 175301-803-A connecting cable and gland
- Pressure sensor casing with ceramic element, screw connections and burglarproof screw
- Printed circuit board
- Pressure connections G 1/8", external threaded with unscrewed fittings for copper pipe, 6 mm diameter
- Fixing bracket, enclosed loose, with sensor
- Plug DIN 175301-803-A unattached

**AQB2002** Mounting kit for remote mounting with 1 m copper capillary line, both ends prefabricated ready for connection. Thread adapters and terminal nuts made of brass. Pressure connection with G1/8" or G1/2" outer threading.

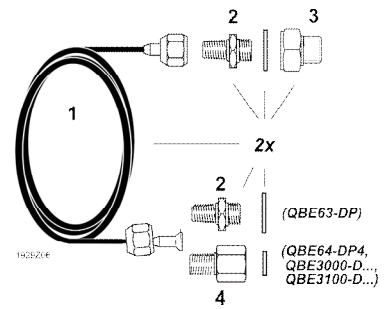

**Mounting instructions**

Mounting instructions are enclosed with the differential pressure sensor.

It can be connected directly with R<sup>1</sup>/<sub>8</sub>" screwed fittings. Special precautions must be taken on site when mounting the sensors to ensure airtight screw connections.

*Recommended measures*

- Use standard T-fittings or drill and de-bur measuring holes, each 5 mm diameter, for the pressure tapping points (A).
- An isolating bypass (5) can be fitted, to avoid overloading the pressure sensor on one side while making adjustments.
- For inspection purposes, measuring circuits can be fitted with a measuring-T at the sensor head.

*Important note*

*Mounting for use with liquids:*

- Always mount the sensor lower than the pressure measuring points
- Mount on a vibration-free surface
- Always evacuate the system

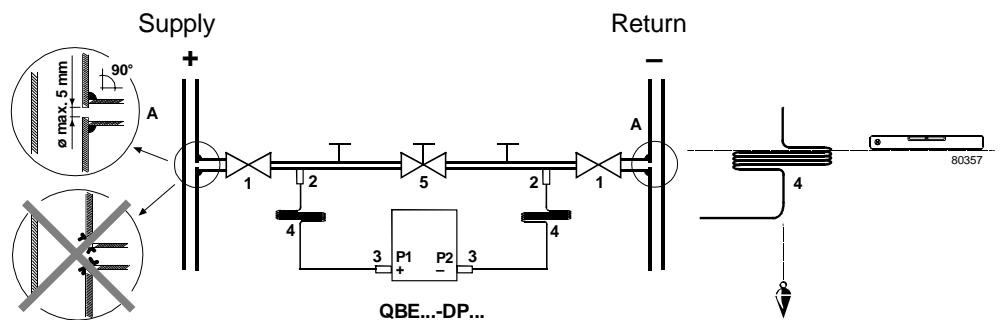

- Key:
- A Measuring holes
  - 1 Isolating valves
  - 2 T-joints
  - 3 Connection pieces (from mounting kit AQB 2002)
  - 4 Copper pipes (from mounting kit AQB 2002)
  - 5 Isolating bypass

*Remote mounting*

For remote mounting, the sensor can be operated together with the AQB pressure mounting kit in ambient temperatures of up to 70 °C for medium temperatures of up to 180 °C. Care must be taken in this case to ensure that the cooling efficiency of the copper pipe is not reduced by additional heat sources or by restrictions to the air circulation.

## Disposal



The devices are considered electronics devices for disposal in terms of European Directive 2012/19/EU and may not be disposed of as domestic waste.

- Dispose of the device via the channels provided for this purpose.
- Comply with all local and currently applicable laws and regulations.

## Technical data

Power supply	Low voltage (SELV)	
Operating voltage QBE3000-D..	AC 24 V $\pm$ 15 %, 50/60 Hz or DC 18-33 V	
Power consumpt. (at nom. pressure)	at AC 24 V: < 5 mA	
Operating voltage QBE3100-D..	DC 11-33 V	
Power consumpt. (at nom. pressure)	< 20 mA	
Frequency	50/60 Hz at AC 24 V	
External supply line protection	Fuse slow max. 10 A or Circuit breaker max. 13 A Characteristic B, C, D according to EN 60898 or Power source with current limitation of max. 10 A	
Output signal	Short-circuit proof and proof polarity reversal	
QBE3000-D..	DC 0...10 V	
Working resistance	> 10 k $\Omega$	
QBE3100-D..	DC 4...20 mA	
Working resistance	$\leq \frac{\text{Power supply} - 11 \text{ V}}{0.02 \text{ A}}$ [Ohm]	
Product data	Differential pressure range	Refer to "Type summary"
	Measuring element	Ceramic
	Measuring accuracy	Factory calibrated
	Sum of linearity, hysteresis and repeatability	< $\pm$ 0.5 % FS (FS = Full Scale)
	Zero point, Full scale	< $\pm$ 0.4 % FS
	TC zero point	< $\pm$ 0.04 % FS/K
	TC sensitivity	< $\pm$ 0.015 % FS/K
	Long-term stability DIN EN 60770	$\pm$ 0.5 % FS
	Resolution	0.1 % FS
	Overload on one side P1 / P2	$\leq$ 2 x nominal pressure
	System pressure at nom. pressure range	(simultaneous P1 and P2)
	$\leq$ 6 bar	25 bar
	$\geq$ 10 bar	50 bar
	Bursting pressure	1.5 x system pressure
	Dynamic response:	
	Response time	< 5 ms
	Load alternation	< 50 Hz
	Suitable media	Air, mildly corrosive gases, liquids
	Admissible temperature of medium	-15...+85 °C
	Maintenance	No maintenance required

Degree of protection	Protection degree of housing	IP65 according to EN 60529, mounted and tightened
	Protection class	III according to EN 60730-1
Connections	Connecting cable	Plug DIN EN 175301-803-A, plug with seals and PG9 cable glands included
	Pressure connections	Male-threaded G <sup>1</sup> / <sub>8</sub> ", With screwed fittings for copper pipes, 6 mm diameter
Mountings	Mounting bracket	For mounting in ducts, on walls or ceilings, in contr.panels
	Orientation	Any (factory-calibrated with pressure connections at bottom)
Environmental conditions	Perm. ambient temperature	
	Operation	-15...+85 °C
	Storage/Transport	-40...+85 °C
	Perm. ambient humidity	<90 % r. h. (non-condensing)
Directives and Standards	Product standard	EN 61326-1 Electrical equipment for measurement, control and laboratory use.
	EU Conformity (CE)	CA1T1923xx <sup>*)</sup>
	RCM Conformity	8000078879 <sup>*)</sup>
Environmental compatibility	The product environmental declaration CE1E1922*) contains data on environmentally compatible product design and assessments (RoHS compliance, materials composition, packaging, environmental benefit, disposal).	
Materials	Pressure casing, cover	Aluminium (AlMgSi1)
	Parts in contact with medium	Stainless steel (1.4305), ceramic element
	Sealant	FPM (fluoroelastomer)
	Mounting bracket	Stainless steel (1.4305)
	Mounting kit AQB2002	See "Accessories"
Weight	Including packaging	0.43 kg

\*) The documents can be downloaded from <http://siemens.com/bt/download>.

## Connection terminals

Voltage output:

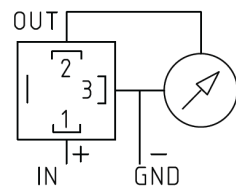

Current output:

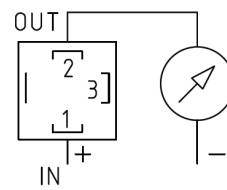

IN	G	Operating voltage AC 24 V or DC 18-33 V or DC 11-33 V
OUT	U	Output signal DC 0-10 V (reference point GND)
	I	Output signal DC 4-20 mA
GND	G0	Ground

## Dimensions

Dimensions in mm

