

# SIEMENS



## **Synco™, Synco™ living Web server OZW772... V5.0** Commissioning instructions

**OZW772.01  
OZW772.04  
OZW772.16  
OZW772.250**

Siemens Switzerland Ltd  
Infrastructure & Cities Sector  
Building Technologies Division  
Gubelstrasse 22  
6301 Zug  
Switzerland  
Tel. +41 41-724 24 24  
[www.siemens.com/sbt](http://www.siemens.com/sbt)

© 2009-2014 Siemens Switzerland Ltd  
Subject to change

# Table of contents

---

<b>1</b>	<b>Overview .....</b>	<b>6</b>
1.1	Introduction .....	6
1.2	Web server display and operating elements.....	7
1.3	User interface.....	8
1.3.1	User levels .....	9
1.4	Symbols, notations, abbreviations .....	10
1.4.1	Symbols .....	10
1.4.2	Notations .....	11
1.4.3	Abbreviations .....	11
<b>2</b>	<b>Commissioning .....</b>	<b>12</b>
2.1	Prerequisites .....	12
2.2	Getting started.....	13
2.2.1	Turn on web server .....	13
2.2.2	Log into web server.....	14
2.3	Administer user accounts.....	15
2.4	Create device web pages .....	17
2.5	Web server settings .....	20
2.5.1	Operating page settings "Time of day/date" .....	20
2.5.2	Operating page settings "Settings" .....	21
2.6	Commission network components .....	31
2.6.1	Operator station on a local area network (LAN) .....	31
2.6.2	Router .....	32
2.7	Functional check .....	33
2.8	Additional settings.....	35
2.9	Final steps .....	36
2.9.1	Check faults .....	36
2.9.2	Final steps on web server .....	36
2.10	Supply state .....	37
2.11	Software updates .....	37
<b>3</b>	<b>Operate using a web browser.....</b>	<b>38</b>
3.1	Overview .....	38
3.2	Operate the plant .....	40
3.2.1	Operate Synco device.....	40
3.2.2	Operate web server .....	40
3.2.3	Web server diagnostics.....	42
3.3	Faults .....	44
3.3.1	Overview .....	44
3.3.2	Device faults.....	44
3.4	File transfer .....	46
3.5	Operation with ACS790.....	50
<b>4</b>	<b>Visualize plants .....</b>	<b>51</b>
4.1	Overview .....	51
4.2	Example of a plant web page.....	52
4.3	Plant web page features .....	53

4.4	Toolbar.....	54
4.5	Import web-capable plant diagrams.....	55
4.6	Create own plant web pages.....	57
<b>5</b>	<b>Record consumption data.....</b>	<b>61</b>
5.1	Consumption data file .....	62
5.1.1	Main areas for consumption data file .....	62
5.1.2	Meter data in detail.....	63
5.2	Time ratios.....	64
5.3	Send consumption data file.....	67
<b>6</b>	<b>"Energy indicator" function .....</b>	<b>68</b>
6.1	Introduction.....	68
6.1.1	Function description .....	68
6.1.2	KNX bus topology .....	69
6.1.3	Synco product range .....	70
6.1.4	Navigation and device web pages .....	71
6.2	"Energy indicator" function levels.....	72
6.2.1	"Plant" level .....	72
6.2.2	"Partial plants" level.....	73
6.2.3	"Data points" level .....	74
6.2.4	Number of "Monitored data points" .....	75
6.2.5	"Energy indicator" visibility .....	76
6.2.6	Summary display "Energy indicator" for a plant.....	77
6.3	"Energy indicator" commissioning function .....	78
6.3.1	Commissioning notes.....	78
6.3.2	Start "Energy indicator" function.....	78
6.3.3	Estimated processing time .....	79
6.3.4	Deactivating "Data point monitoring".....	79
6.3.5	Activating "Data point monitoring" .....	81
6.4	Dialog boxes, data points, and "Green limits" .....	83
6.4.1	General dialog boxes .....	83
6.4.2	Dialog boxes with numeric data points.....	84
6.4.3	Dialog boxes with enumeration data points .....	85
6.4.4	Dialog boxes with variable unit data points.....	86
6.4.5	Dialog boxes for data points with manually set value .....	87
6.4.6	User groups "Service" and "End user" .....	88
6.5	E-mail with "Energy indicator" for the plant.....	89
6.5.1	E-mail receiver configuration.....	89
6.5.2	Mail inbox .....	90
6.5.3	E-mail contents.....	91
6.6	Exceptions.....	92
<b>7</b>	<b>Communications .....</b>	<b>93</b>
7.1	Remote operation.....	93
7.1.1	Local area network (LAN) .....	93
7.1.2	Remote operation via the Internet.....	97
7.2	Messages via e-mail .....	101
<b>8</b>	<b>Trend functions .....</b>	<b>106</b>
8.1	Overview .....	106
8.2	Define trend.....	107
8.2.1	Define trend via web .....	107
8.2.2	Restriction to bus load.....	110

8.2.3	Reset trend definition .....	110
8.2.4	Add trend data points .....	111
8.2.5	Manage trend RAM .....	112
8.3	Send trend data by e-mail .....	113
8.3.1	Configure E-mail receiver .....	113
8.3.2	Sent transmission options per trend channel.....	114
8.3.3	E-mail content and appendix .....	115
8.4	Download trend file via web .....	117
8.5	Import/export trend definitions .....	118
8.6	ACS Trend.....	121
8.6.1	ACS offline trend compatibility .....	121
8.6.2	ACS trend bus load .....	121
<b>9</b>	<b>KNX S-Mode.....</b>	<b>122</b>
9.1	Configuration in KNX S-Mode.....	124
9.2	Operation KNX S-mode .....	139
<b>10</b>	<b>Appendix.....</b>	<b>142</b>
10.1	General notes.....	142
10.2	Diagnostics.....	142
10.2.1	Web server fault codes .....	142
10.2.2	Windows Commander.....	143
10.3	Communications .....	144
10.3.1	Internet protocol .....	144
10.3.2	Free e-mail account providers .....	144
10.3.3	Install RNDIS driver.....	145
10.3.4	Alternative network configuration.....	148
10.4	Glossary of Ethernet and Internet terms.....	150
<b>Index</b>	<b>.....</b>	<b>157</b>

# 1 Overview

## 1.1 Introduction

### Type summary

Type designation	Max. number of devices on KNX bus
OZW772.01	1 device
OZW772.04	4 devices
OZW772.16	16 devices
OZW772.250	250 devices

### Document contents

The document describes commissioning and operating the web server OZW772. This edition of "Web-Server OZW772, V5.0" included a new description of the KNX S-Mode integration in Section 10. The latest edition is available on [www.siemens.com/ozw772-manual](http://www.siemens.com/ozw772-manual).

### Focus on web browser operation

The ACS790 PC software can also be used to commission and operate the web server OZW772. To simplify reading, this document focuses on commissioning and operating via web browser.

### Important notes

The symbol to the right identifies special safety notes and warnings. Ignoring this type of note may result in device damage and personal injury.

### Safety / Product liability

- Devices may only be used in building technical plants and for the described applications only. Comply with all local regulation (installation, etc.).
- Disconnect the power and immediately replace a defective or obviously damaged device.
- Do not open the device. Failure to comply will invalidate any warranty claims.
- The technical data are provided solely for use with Siemens bus devices. The user ensures the functionality of operation when using third-party devices not expressly mentioned here. Siemens assumes **no** responsibility for service and warranty under these circumstances.

### Intended use

Trouble-free and safe product operation presupposes transport, storage, mounting, installation, and commissioning as intended as well as careful operation.

### Disposal



The devices are considered electronics devices for disposal in terms of European Directive 2012/19/EU and may not be disposed of as domestic waste.

- Dispose of the Device via the channels provided for this purpose.
- Comply with all local and currently applicable laws and regulations.

## 1.2 Web server display and operating elements

### Overview

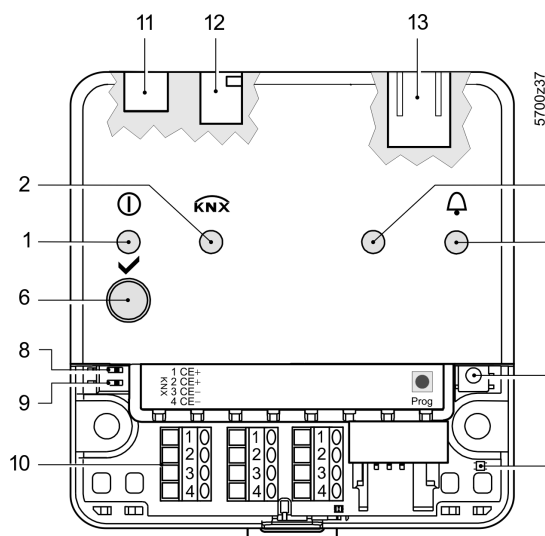

Pos	Designation
1	LED ⓘ Operation and "Energy indicator"
2	LED <b>KNX</b>
3	LED field bus 2 (reserve)
4	LED fault ⓘ
5	LED addressing mode
6	Remote button ✓
7	Addressing mode button Prog
8	"Message suppression" switch
9	Switch 2 (no function)
10	KNX bus connection terminals
11	Operating voltage connection
12	USB connection Mini-B
13	Ethernet connection, RJ45 plug

### LED displays

- 1 ⓘ (red/green/orange)
- Dark No operating voltage DC 24 V
  - Steady red Web server starts operating system
  - Flashing red Web server starts application
  - Steady green Web server operational, "Energy indicator" = "Green leaf"
  - Steady orange Web server operational, "Energy indicator" = "Orange leaf"

- 2 **KNX** (green)
- Dark No bus power
  - Lit KNX operational
  - Flashing Communication on KNX

- 3 Field bus 2 (reserve)
- Dark No function

- 4 Fault ⓘ (red)
- Dark No fault (normal operating state)
  - Lit Acknowledged fault
  - Flashing Unacknowledged fault

- 5 Addressing mode (red)
- Dark KNX addressing mode off
  - Lit KNX addressing mode on

### Operating buttons

- 6 Remote button ✓
- Short (< 2 s) Acknowledges fault message
  - Long (> 6 s) Sends system report to fault e-mail Receivers (not to consumption data and "Energy indicator" Receivers)

- 7 Addressing mode Prog
- Short (< 2 s) Press once: KNX addressing mode on  
Press again: KNX addressing mode off

- Button combinations  
✓ and Prog
- Long (> 6 s) Simultaneously pressing the buttons ✓ and Prog restores defaults  
**i** All configuration data and settings are reset. The device list, plant diagrams, and unsent messages are deleted. History data is not deleted.

### Switches

- 8  Message suppression
- Position ON  Sending messages is suppressed
  - Position OFF  Sending messages permitted

- 9  DIP switch 2
- Switch settings No function

## 1.3 User interface

A web browser is used to access the user interface for the web server.

- The web server provides text-based operation of the web server and connected Synco devices as a standard (Section 3).
- You can also set up visualized operation (Section 4).

The following describes the display areas for the text-based standard user interface (display areas for visualization are outlined in Section 4).

The main window is sub-divided into various areas.

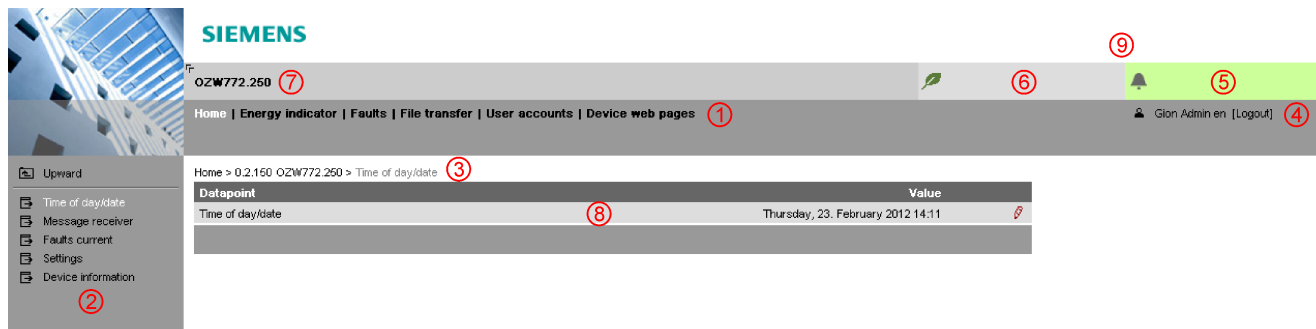

### ① Primary navigation

The following functions are selected via primary navigation:

Home	Menu-based plant and device operation.
Energy indicator	Display and operate "Energy indicator" data points.
Faults	Display system faults.
File transfer	Download consumption data and event history, upload documents, logos and system definitions.
User accounts	User administration.
Device web pages	Create device list and operating pages.

### ② Secondary navigation

Device operation (via home) queries devices and their operating pages via secondary navigation (menu tree). As of OZW-Version 5.0, KNX pages defined in ETS are displayed here too.

### ③ Command sequence

The path displays the workflow starting at the main menu to the open operating page. Simply click at any point on the path to return to that location.

### ④ User

This field shows the currently logged-in user. Clicking [Logout] ends the current session. The session remains active until logout.

### ⑤ Plant state fault

The "Plant state fault" field is displayed permanently:

- Green field: No fault
- Red field: Plant fault

Click the "Plant state fault" field to display all faults in the plant.

### ⑥ Plant state Energy indicator

The "Plant state Energy indicator" field is displayed permanently:

- Green leaf: All "Energy indicator" data points are always within their "green limits", i.e. "within the green/allowed range".
- Orange leaf: One or multiple "Energy indicator" data points are outside their "green limits"

Clicking the "Plant state Energy indicator" field opens the "Energy indicator" function.



- ⑦ **Plant name**                      Displays plant name as entered.
- ⑧ **Display**                              The display range displays content corresponding to the selected function via primary and secondary navigation.
- ⑨ **Logo area**                           Shows Logo 1 and Logo 2.

### 1.3.1 User levels

Displays and operates based access level for the logged on user:

#### End user

- Operate end user data
- Operating of KNX S-Mode devices
- Fault overview
- Administer own user account



#### Service

Same as end user. In addition:

- Operate service data
- Documents, message history

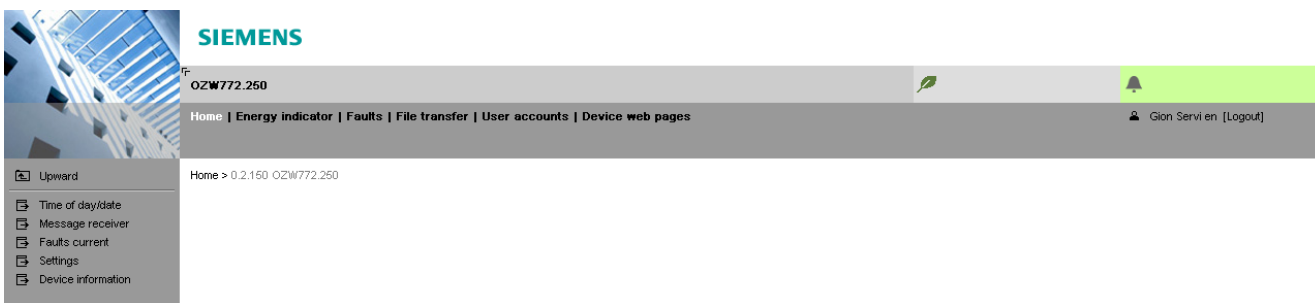

#### Administrator

Same as service. In addition:



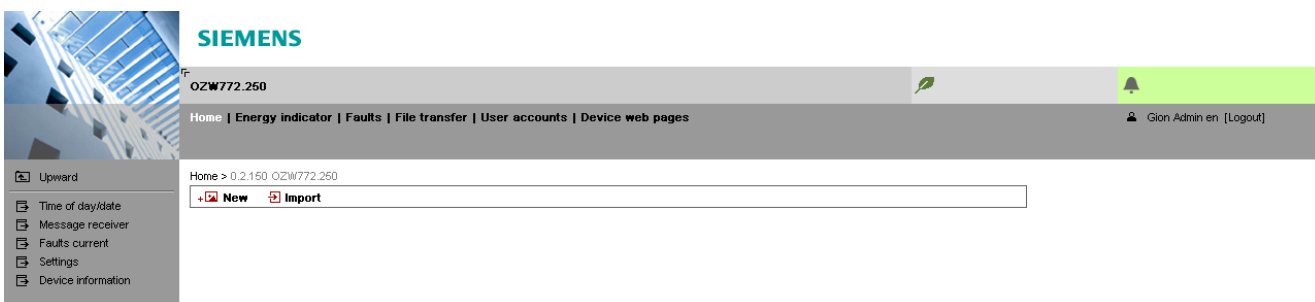

























- Create device list and web pages
- The toolbar to create plant web pages
- Administer all user accounts



## 1.4 Symbols, notations, abbreviations

### 1.4.1 Symbols

#### Symbols

Symbol	Meaning
	Data point at the service level
	Data point at the end user level
	Read/write data point; the setting value can be changed
	Read-only data point; the value cannot be changed
	Link to entry field
	Delete object
	Checkbox
	Selection box
	Calendar
	Arrows to incrementally adjust values
	Adjustment tab
	Arrow to display sort order
	Up
	File upload (to web server)
	File download (from web server)
	Safety note, intended to protect against misuse
	Always observe/follow
	Note; important information
	Network connection
	Link to device
	User
	Message history
	System definitions
	Logos
	Switch over displays: Full view, partial view
	Fault indication: Green field = no fault; red field = fault (alarm)
	"Green leaf"
	"Orange leaf"
	"Grey leaf"

## 1.4.2 Notations

---

### Path indications

Paths are printed as follows:

- Web server: Home > 0.2.150 OZW772.xx > Settings > Time of day/date.
- PC: *Start > Settings > Network connections > Local Area Connection.*

OZW772.xx stands for: OZW772.01 or  
OZW772.04 or  
OZW772.16 or  
OZW772.250

### IP address, domains

Enter in the browser address line:

- IP address: [192.168.2.10](http://192.168.2.10)
- Domain: [www.siemens.com](http://www.siemens.com)

### Buttons

Buttons depicted as follows: [ Add ]

## 1.4.3 Abbreviations

---

### Abbreviations

Auto MDI-X	Auto Medium Dependent Interface – Crossed.
COV	Change of value
DynDNS	Dynamic Domain Name System
ECA	Energy Cost Allocation
HTTP	Hyper Text Transfer Protocol
HTTPS	Hyper Text Transfer Protocol Secure
IP	Internet Protocol
KNX	Konnex
LAN	Local Area Network
NAT	Network Address Translation
PAT	Port and Address Translation
RNDIS	Remote Network Driver Interface Specification
SMTP	Simple Mail Transfer Protocol
STP	Shielded Twisted Pair
TCP	Transmission Control Protocol
TLS	Transport Layer Security
UPnP	Universal Plug and Play
USB	Universal Serial Bus
UTP	Unshielded Twisted Pair
Web API	Web Application Programming Interface

The glossary, Section 10.4, contains detailed explanations of terms and abbreviations.

## 2 Commissioning

---

This section describes how to commission the web server.

### 2.1 Prerequisites

---

#### Prerequisites

The following conditions must be met to commission the web server:

- The web server is mounted and wired (see Installation instructions, G5701).
- The connected KNX devices are commissioned.
- The KNX devices have a valid KNX address [1...253] are operating.  
Note: Web servers are delivered with KNX address 150. As a result KNX address range [1...253], except for 150, applies to all other devices.
- Bus power supply to the KNX bus is available.
- The web server or another KNX device is the clock master on KNX.
- Connecting a SmartPhone App to a web server makes sense only after the web server is fully commissioned.

#### Notes





- IP address USB: [192.168.250.1](#) (cannot be changed)  
The address range 192.168.250.1 - 192.168.250.255 cannot be used for Ethernet and is reserved for USB only.
- IP address Ethernet: As per the address assigned by the router.  
Without router: [192.168.2.10](#) (default state, see Section 7.1.1)
- Commissioning with a PC/laptop and a web browser via the USB interface.  
The RNDIS driver must be installed to connect via USB.
- The RNDIS driver is automatically installed when connecting via USB if the PC/laptop is connected to the Internet (as long as the Microsoft online update is enabled). You can manually install the RNDIS driver when there is no connection to the Internet (see Section 10.3.3).
- The RNDIS driver is supplied on the web server at <http://<IP-Adresse>/drivers/>.
- To navigate, always start with primary navigation, then use the secondary navigation to select the desired menu item.
- Return: Click "Upward" or navigate via the path or primary navigation.

## 2.2 Getting started

### 2.2.1 Turn on web server

#### Turn on web server

Connect the web server to the power supply and connect it to the PC:

1. Connect power supply to turn on power on web server. The web server is operational, when the green  LED is lit.
2. Check additional displays:
  - LED   
Green light if the KNX bus power supply is available. Check KNX bus wiring and setting for bus power supply on the KNX devices if no bus power supply is available.
  - LED   
Dark if no fault pending. You can troubleshoot pending faults later (see Section 3.3).
3. Plug the supplied USB cable into the web server and the PC and start up the PC. The PC recognizes the web server as a USB device. Otherwise, the RNDIS is still not installed.

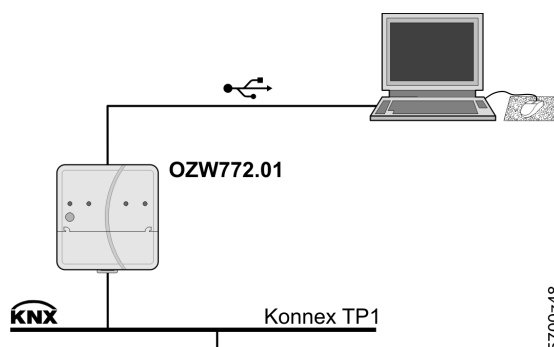

4. The RNDIS driver is installed automatically if the PC is connected to the Internet and no RNDIS driver is installed as long as the Microsoft online update is enabled. Follow the instructions for the installation program.

#### Note

 You can also manually setup the RNDIS driver (see Section 10.3.3).

## 2.2.2 Log into web server

### Log on

A PC with USB interface and web browser is used to commission the web server.

1. Start web browser.
2. In the address line, enter the USB IP address ([192.168.250.1](http://192.168.250.1)).

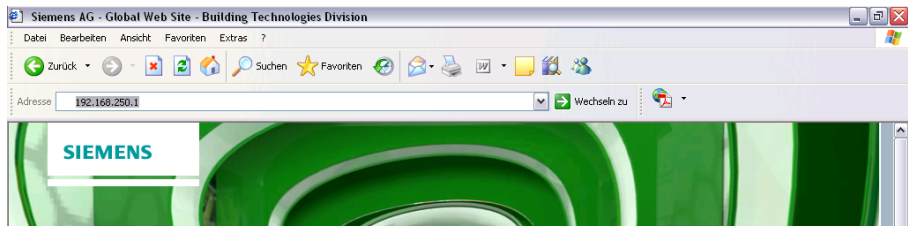

3. First time Login
  - User name *Administrator*
  - Password *Password*

Login	
User name	<input type="text" value="Administrator"/>
Password	<input type="password" value="....."/>
<input type="button" value="Login"/>	

4. Click [ Login ] to finish.
5. After logging on the first time, the dialog box is displayed to define a new password.

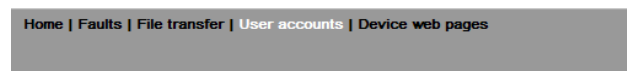

Change user	
User name	<input type="text" value="Administrator"/>
Password	<input type="text"/>
Repeat password	<input type="text"/>
Description (optional)	<input type="text"/>
E-mail address (optional)	<input type="text"/>
Language	<input type="text" value="English"/>
<input type="button" value="OK"/>	

### Important note



- **A new password must** be defined the first time you log in (you can also change the language).
- You cannot exit the dialog box if you do not define a new password (i.e. not equal to "Password") and the following note is displayed:



- The following message is displayed if you fail to fill out all required fields:

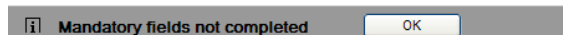

- Capitalization must be observed when entering the password.

## 2.3 Administer user accounts

### Administer user accounts

The "User Accounts" ("User accounts") menu changes the administrator password at delivery and sets up additional user accounts.

### Note

-  The user account settings equally apply to access via Smartphone app and other applications via Web API.

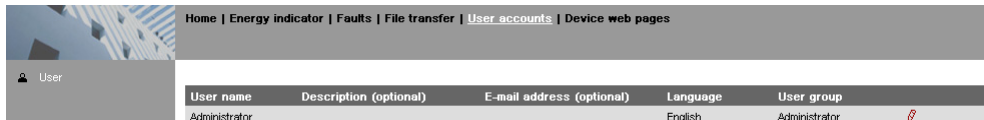

User name	Description (optional)	E-mail address (optional)	Language	User group
Administrator			English	Administrator 

### Change administrator data

Procedure:

1. Click red pencil   
The "Change user" dialog box opens.

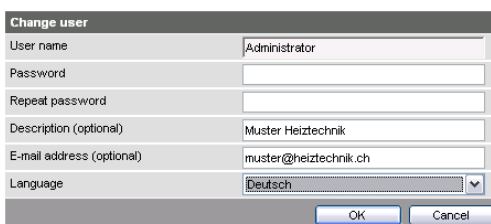

2. Change administrator data:
  - Password
  - Repeat Password
  - Description (optional)
  - E-mail address (optional)
  - Language: English
3. Close with [ OK ]

### Add a new user

Procedure:

1. Click [ Add ]  
The "Add user" dialog box opens.

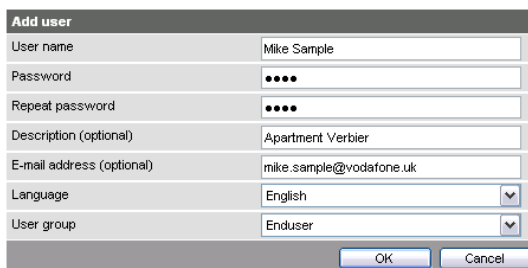

2. Enter / Select user data:
  - User name
  - Password
  - Repeat password
  - Description (optional)
  - E-mail address (optional)
  - Language: English
  - User group
3. Close with [ OK ]

## Change user data

Procedure:

1. Click the red pencil  for the corresponding user  
The "Change user" dialog box opens.

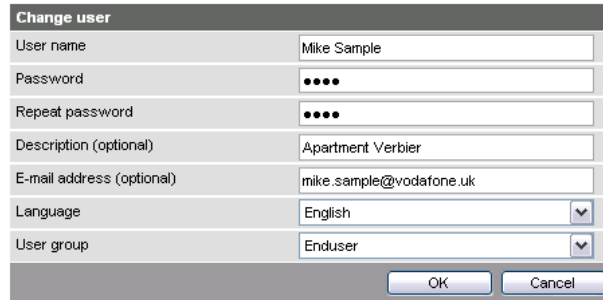

Change user	
User name	Mike Sample
Password	••••
Repeat password	••••
Description (optional)	Apartment Verbier
E-mail address (optional)	mike.sample@vodafone.uk
Language	English
User group	Enduser

2. Change user data:
  - User name
  - Password
  - Repeat password
  - Description (optional)
  - E-mail address (optional)
  - Language: English
  - User group.
3. Close with [ OK ]

## Delete user account

Procedure:

1. Click the red recycle bin  for the corresponding user.  
The "User accounts" dialog box opens.



User accounts	
[?] User to be deleted?	Yes No

2. Click [ Yes ] to confirm "User to be deleted?".

## Notes



- The administrator account cannot be deleted. The name "Administrator" and user group "Administrator" cannot be changed. You may, however, add user accounts with administrator rights.
- You can only add new users and delete existing ones on the "Administrator" user level.
- Changing other user accounts is reserved to the "Administrator" user level.
- A secure password is comprised of letters, numbers and special characters, is at least 20 characters in length and does not include a name or words from dictionaries.



## 2.4 Create device web pages

### Create device websites

The associated devices must be recorded and the device websites generated before operating the web server and the Synco devices. Use the "Device web pages" menu.

### Note

 Device web pages can only be created on the "Administrator" user level.

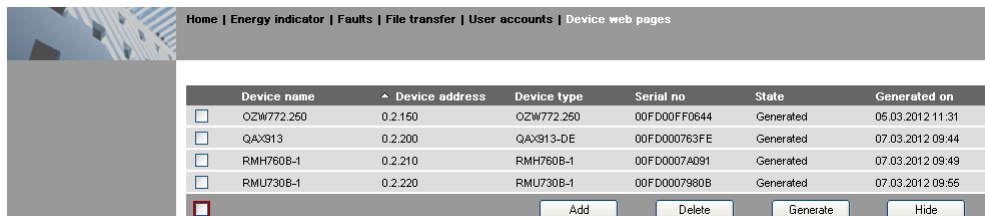

Device name	Device address	Device type	Serial no	State	Generated on
<input type="checkbox"/> OZW772.250	0.2.150	OZW772.250	00FD00FF0644	Generated	05.03.2012 11:31
<input type="checkbox"/> QAX913	0.2.200	QAX913-DE	00FD000763FE	Generated	07.03.2012 09:44
<input type="checkbox"/> RMH760B-1	0.2.210	RMH760B-1	00FD0007A091	Generated	07.03.2012 09:49
<input type="checkbox"/> RMLU730B-1	0.2.220	RMLU730B-1	00FD0007980B	Generated	07.03.2012 09:55

Linked devices are listed in a table with the following information:

- Device name
- Device address
- Device type
- Serial number
- State
- Generated on

You can sort the table by clicking 

### Notes

-  The web server itself is already in the device list.
- Only added devices are monitored.
- Only generated devices can be operated.
- Device web pages can only be generated on the "Administrator" user level.
- Changes to settings of the connected Synco device may require that the device web pages be recreated or updated to apply changes from web operation.
- You must delete and re-add to replace a Synco device.

### Add devices

Procedure:

1. Click [ Add ]
2. Enter serial number.



 The serial number is located on the type label for Synco devices.

3. Confirm with [ OK ]  
The web server searches for the device with the corresponding serial number. It appears in the device list if found.

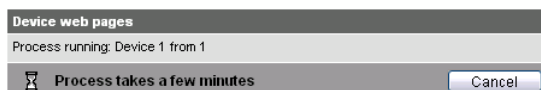

4. Select  devices whose web pages you want to create.

Device name	Device address	Device type	Serial no	State	Generated on
<input type="checkbox"/> OZW772.250	0.2.150	OZW772.250	00FD00FF0644	Generated	05.03.2012 11:31
<input type="checkbox"/> QAX913	0.2.200	QAX913-DE	00FD000763FE	Generated	07.03.2012 09:44
<input type="checkbox"/> RMH760B-1	0.2.210	RMH760B-1	00FD0007A091	Generated	07.03.2012 09:49
<input checked="" type="checkbox"/> RMU730B-1	0.2.220	RMU730B-1	00FD0007980B		
<input checked="" type="checkbox"/> Device 230	0.2.230	RMU730-1	00FD00001DF7		

Add Delete Generate Hide

5. Click [ Generate ]  
Device web pages are generated.

The process may take a few minutes.



6. Wait until the message " Process finished" is displayed.



7. Close with [ OK ]

The device list for the web server and Synco devices displays status "Generated".

Device name	Device address	Device type	Serial no	State	Generated on
<input type="checkbox"/> OZW772.250	0.2.150	OZW772.250	00FD00FF0644	Generated	05.03.2012 11:31
<input type="checkbox"/> QAX913	0.2.200	QAX913-DE	00FD000763FE	Generated	07.03.2012 09:44
<input type="checkbox"/> RMH760B-1	0.2.210	RMH760B-1	00FD0007A091	Generated	07.03.2012 09:49
<input type="checkbox"/> RMU730B-1	0.2.220	RMU730B-1	00FD0007980B	Generated	07.03.2012 09:55
<input type="checkbox"/> Device 230	0.2.230	RMU730-1	00FD00001DF7	Generated	07.03.2012 10:12

Add Delete Generate Hide

## Delete device

Procedure:

1. Select the Synco device you want to remove from the device list

<input type="checkbox"/> RMU730B-1	0.2.220	RMU730B-1	00FD0007980B	Generated	07.03.2012 09:55
<input checked="" type="checkbox"/> Device 230	0.2.230	RMU730-1	00FD00001DF7	Generated	07.03.2012 10:12

Add Delete Generate Hide

2. Click [ Delete ]  
3. Confirm with [ Yes ]



4. The web server removes the device from the device list.

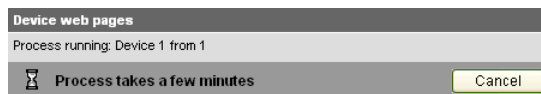

5. Wait until the message " Process finished" is displayed.



6. Click [ OK ] to confirm.  
The device is deleted from the device list.

Device name	Device address	Device type	Serial no	State	Generated on
<input type="checkbox"/> OZW772.250	0.2.150	OZW772.250	00FD00FF0644	Generated	05.03.2012 11:31
<input type="checkbox"/> QAX913	0.2.200	QAX913-DE	00FD000763FE	Generated	07.03.2012 09:44
<input type="checkbox"/> RMH760B-1	0.2.210	RMH760B-1	00FD0007A091	Generated	07.03.2012 09:49
<input type="checkbox"/> RMU730B-1	0.2.220	RMU730B-1	00FD0007980B	Generated	07.03.2012 09:55

Add Delete Generate Hide

## Update device web pages

The following changes to user defined texts result in outdated device web pages:

- Menu tree names \*, e.g. Message receiver 1...4.
- Web server plant names.
- Plant names for Synco devices (e.g. QAX913).

The impact and restore differ for the three changes mentioned above based on internal KNX data storage.

Change	Device list (device web pages)		Texts in sec. navigation		Generate/Update	Delete, Add
	Device name	Status	Menus	Device nodes		
Menu tree names *, e.g. Message receiver 1...4	n/a	Outdated	Outdated	n/a	Required	no
Web server plant name	Current	Generate	Current	Outdated	Required	no
Plant name for Synco device(s)	Outdated	Generate	Current	Outdated **	No	Required

\* Menu tree names are user defined texts displayed in secondary navigation (menu tree)

\*\* Even after generate

## Notes



- You can update device web pages on user levels "Administrator" and "Service".
- Click "Update" on the service level and "Generate" on the Administrator level to start updating (see "Create device web pages").
- You can only delete a Synco device on the "Administrator" user level.

## Tip

When deleting or adding a Synco device (see above for description of workflow), we recommend copying (select and right-click: Copy) the serial number to the clipboard prior to deleting.

## 2.5 Web server settings

The "Home" menu is used to set the web server. The web server and then the corresponding operating page are selected in secondary navigation.

Note

 The settings depend on the user level.



### 2.5.1 Operating page settings "Time of day/date"

**Time of day/date**

Path: Home > 0.2.150 OZW772.xx > Time of day/date

Power reserve

 The clock has a backup battery for at least 72 hours. The clock continues to run after power failure for the duration of the backup battery.





Both date and time are reset in case of an extended interruption.

- It is corrected automatically if the time is synchronized to the master clock on the KNX bus (see Section 2.5.2).
- Otherwise, both date and time must be reset.

Note



Time/data can be set during operation. The clock is overwritten by the time master if the web serve time slave does not have remote adjustment.

Data point	Explanation, example		
Time of day/date Default val: 00:00 1.1.2005 Setting val: Time of day/date	The setting values are derived from the current time clock and the current date. Weekday is calculated automatically.		



Datapoint	Value
Time of day/date	Wednesday, 29. February 2012 12:20 

Time of day/date	
Time of day	<input type="text" value="12:21"/>
Date	 <input type="text" value="29.02.12"/>
Weekday	<input type="text" value="Wednesday"/>
<input type="button" value="OK"/> <input type="button" value="Cancel"/>	

## 2.5.2 Operating page settings "Settings"

### Web server



Path: Home > 0.2.150 OZW772.xx > Settings > Web server

Data point	Explanation, example		
Language Default val: English Setting val: see example	Web server language: Is used for web server fault texts, message history, messages and system reports.	●	—
Code Default val: 01 Setting val: max. 20 charact.	Access code for PC Software ACS790.	●	—
Reset admin password * Default val: No Setting val: Yes	If you do not know the administrator password for the web server, setting value "Yes" again provides access to the web server via the administrator password "Password" ("Password" = Factory setting for administrator password). Setting value "Yes" is a temporary state, i.e. the setting value automatically goes to "No" after ca. 2 seconds.	*	*

\* with PC software ACS790 only.

### Time of day/date





Path: Home > 0.2.150 OZW772.xx > Settings > Time of day/date

Data point	Explanation, example		
Time zone Default val: GMT +01:00 Berlin, Rome Setting val: misc. Time zones	The time zone setting value is based on UTC (GMT). The time zone also defines daylight saving time / standard time changeover.	●	—

## Communication

KNX

Path: Home > 0.2.150 OZW772.xx > Settings > Communication > KNX

Data point	Explanation, example		
Range	Displays the range within the KNX bus. e.g. <b>0</b> for address <b>0.2.150</b> The range is set in ETS.	—	—
Line	Display of line within the KNX bus. e.g. <b>2</b> for address <b>0.2.150</b> The line is set in ETS.	—	—
Device address Default val: 150 Setting val: 1... 253	Set device address. The device address must be unique within the same KNX line.		—
Time synchronization Default value: Slave on bus Setting values: Slave on Bus Quartz	Defines time synchronization on the web server. Default value "Slave on bus": Clock master is available on the KNX network. Setting value "Quartz": The clock is synchronized with quartz on the web server. Web server operates a clock master or autonomously.	—	—
Clock time mode KNX Default val: Autonomous Setting val: Autonomous/Master	"Slave" for "Time synchronization" = "Slave on bus". For "Time synchronization" = "Quartz", can be selected between "Autonomous" or "Master".		—
Clock slave remote adj KNX Default val: Yes Setting val: Yes / No	Setting value is important for "Time synchronization" = "Slave on bus". For "Clock slave remote adj KNX" = "Yes" the time clock for the clock master on the KNX network can be changed via the time clock for the web server.		—
Number of devices maximum	Maximum number of supported Synco devices on this OZW	—	—
Number of devices current	Number of Synco devices currently connected to this OZW	—	—
Last change	Last change to bus configuration.	—	—

## Notes



- Enter these settings if you intend to operate the web server on a local area network (LAN) or via the Internet.
- Entries for the various network topologies are described in Section 7.1.

Data point	Explanation, example		
DHCP client Default val: On Setting val: Off, On	Service automatically getting the web server's IP network configuration automatically from the router; see Section 7.1.1.	●	—
IP address Default val: 192.168.2.10 Setting val: IP address	Web server IP address. Does not require setting if "DHCP client = On".	●	—
Subnet mask Default val: 255.255.255.0 Setting val: IP address	The IP subnet mask sets the size of the subnet. Does not require setting if "DHCP client = On".	●	—
Default gateway Default val: 192.168.2.1 Setting val: IP address	The standard gateway represents the interface between the local and public network. You typically enter the IP address for the router here. Does not require setting if "DHCP client = On".	●	—
Preferred DNS server Default val: 192.168.2.1 Setting val: IP address	The DNS server (domain name system) on the Internet connects a globally valid name to a domain with an IP address (e.g. domain <a href="http://www.siemens.com">www.siemens.com</a> with IP address <a href="http://146.254.191.150">146.254.191.150</a> ). The setting corresponds to the IP address for the next router or DNS server that recognizes for its part a queried name (domain) or another DNS server. The setting is typically identical to the setting for the standard Gateway. Required to send e-mails. Does not require setting if "DHCP client = On".	●	—
Alternate DNS server Default val: (blank) Setting val: IP address	The alternative DNS server is only defined for redundant systems. Settings are typically empty. Does not require setting if "DHCP client = On".	●	—
UPnP localization Default val: Ethernet Setting val: ---, Ethernet, USB	The web server registers its presence in the network via the Universal Plug and Play (UPnP) service.	●	—

If the DHCP client is switched off, the corresponding settings must be entered manually.

Set when DHCP client off

IP address	192.168.2.10	
Subnet mask	255.255.255.0	
Default gateway	192.168.2.1	
Preferred DNS server	192.168.2.1	
Alternate DNS server		



Web server registers its existence via Ethernet, when

- "UPnP localization" = "Ethernet" is set *and*
- The connection between PC/laptop and the web server is active via Ethernet.

Home > 0.2.150 OZW772.250 > Settings > Communication > Ethernet

Datapoint	Value
DHCP client	On
IP address	192.168.2.10
Subnet mask	255.255.255.0
Default gateway	192.168.2.1
Preferred DNS server	192.168.2.1
Alternate DNS server	
Set when DHCP client off	
IP address	192.168.2.10
Subnet mask	255.255.255.0
Default gateway	192.168.2.1
Preferred DNS server	192.168.2.1
Alternate DNS server	
UPnP localization	Ethernet
Physical address	00:a0:03:fd:2e:11

E-mail

Path: Home > 0.2.150 OZW772.xx > Settings > Communication > E-mail

Notes



- Enter these settings if the web server sends e-mails (report faults / send consumption file).
- Additional information on e-mail settings is available in Section 7.2.
- Automatically negotiate the securest connection:  
 TLS mode is selected automatically if the device sending the email and the email provider support TLS.



Data point	Explanation, example		
Address mail server Default val: smtp.example.com Setting val: max. 49 characters	Contact the Internet service provider for the mail server's address (IP address) or name (domain). Often referred to as the outgoing mail server or SMTP server instead of mail server.	<input checked="" type="radio"/>	<input type="radio"/>
Port number mail server Default val: 25 Setting val: 1...65535	Port number 25 is default for the mail server (and does not normally require change).	<input checked="" type="radio"/>	<input type="radio"/>
E-mail address sender Default val: ozw772@example.com Setting val: max. 49 characters	The setting corresponds to the e-mail address of the web server. The e-mail address is displayed in the "From" field of each e-mail.	<input checked="" type="radio"/>	<input type="radio"/>
Authentication mail server Default val: No Setting val: No/Yes	Select <b>Yes</b> for mail server access with authentication. In this case, user name and password (see next two data points below) are required.	<input checked="" type="radio"/>	<input type="radio"/>
User name Default val: (blank) Setting val: max. 49 characters	User name and password help authenticate each e-mail via the mail server.	<input checked="" type="radio"/>	<input type="radio"/>
Password Default val: (blank) Setting val: max. 49 characters	Password and user name help authenticate each e-mail via the mail server.	<input checked="" type="radio"/>	<input type="radio"/>



Signature line 1...10 Default val: (blank) Setting val: max. 49 characters	Signature lines are transmitted with the e-mail. It identifies the sender, e.g. the plant's Internet address.	<input checked="" type="checkbox"/>	<input type="checkbox"/>
--	---	-------------------------------------	--------------------------

## USB

Path: Home > 0.2.150 OZW772.xx > Settings > Communication > USB

Data point	Explanation, example		
UPnP localization Default val: USB Setting val: ---, Ethernet, USB	The web server registers its presence in the network via the Universal Plug and Play (UPnP) service.	<input checked="" type="checkbox"/>	<input type="checkbox"/>

## UPnP localization



Web server registers its existence in the USB network, when

- "UPnP localization = USB" is set *and*
- The connection between PC/laptop and the web server is active via USB.

## Message receiver



For each message receiver 1...4, you can define the time range during which messages can be sent.

## Note



The settings are optional, if the web server sends a message via e-mail in the event of a fault.

Path: Home > 0.2.150 OZW772.xx > Settings > Message receiver > Message receiver 1...4

Data point	Explanation, example		
Message receiver 1...4 Def' value: (message receiver x) Setting values: max. 20 characters	Message receiver 1...4 is a name (text) and is displayed in the web browser. Update reference to menu texts => Either "update" or newly "generate" device web page of the web server.	<input type="checkbox"/>	<input type="checkbox"/>
Receiver type Default value: --- Setting values: --, E-mail	All Receiver types are available: "---": No messages to this message receiver. "E-mail": Configure message receiver for e-mail.	<input type="checkbox"/>	<input type="checkbox"/>
Fault priority Default value: All Setting values: All, Only urgent ones	The setting value "Only urgent ones" acts as a filter for sending fault messages.	<input type="checkbox"/>	<input type="checkbox"/>
E.mail address Default value: messagereceiver @example.com Setting values: max. 49 characters	The setting value must match the e-mail address of the message receiver.	<input type="checkbox"/>	<input type="checkbox"/>
Number of messages for send	Number of messages to be transmitted at next send.	<input type="checkbox"/>	<input type="checkbox"/>

Send messages

Path: Home > 0.2.150 OZW772.xx > Settings > Message receiver > Message receiver 1 > Send messages...4

Data point	Explanation, example		
Monday...Sunday, Special day Default val: Monday, 00:00 On ... Special day, 00:00 On ... Setting val: Monday - Sunday, Special day 00:00 - 24:00 Off/on	Each message receiver is assigned a time switch to program max. 3 transmission times for each weekday, i.e. periods during which the web server can send messages. The default value sends messages throughout the entire period.		

Notes

- Check  to enable switching points.
- You can copy the switching times for a day of the week by clicking [ Copy ] from one day to a selection of other days
- Click [ Check ] to sort and check the data before saving.

Holidays/special days

Path: Home > 0.2.150 OZW772.xx > Settings > Message receiver > Message receiver 1...4

> Holidays/special days

No messages are sent during vacation/holidays. For special days, sending periods are defined via "Send messages".

Notes

- General: Messages outside sending periods are resent during the next send period.
- If a special day occurs during a holiday/vacation, the day is a special day.
- Holidays/special days can be set as recurring days each year.

Data point	Explanation, example		
Entry 1...16 Default val: --- Setting val: Beginning End Reason Annually	Each receiver is assigned a yearly calendar to enter holidays and special days. Data and time can be used to indicated beginning and end of period. Select "Annually" to repeat the periods each year.		

	Beginning	End	Reason	Annually
1	<input checked="" type="checkbox"/> 14.07.09 00:00	29.07.09 23:59	Holidays	<input type="checkbox"/>
2	<input checked="" type="checkbox"/> 24.12.** 00:00	02.01.** 23:59	Holidays	<input checked="" type="checkbox"/>
3	<input checked="" type="checkbox"/> 01.08.** 00:00	01.08.** 23:59	Special day	<input checked="" type="checkbox"/>
4	<input type="checkbox"/> 01.01.00 00:00	01.01.00 23:59	Holidays	<input type="checkbox"/>
5	<input type="checkbox"/> 01.01.00 00:00	01.01.00 23:59	Holidays	<input type="checkbox"/>
6	<input type="checkbox"/> 01.01.00 00:00	01.01.00 23:59	Holidays	<input type="checkbox"/>
7	<input type="checkbox"/> 01.01.00 00:00	01.01.00 23:59	Holidays	<input type="checkbox"/>
8	<input type="checkbox"/> 01.01.00 00:00	01.01.00 23:59	Holidays	<input type="checkbox"/>
9	<input type="checkbox"/> 01.01.00 00:00	01.01.00 23:59	Holidays	<input type="checkbox"/>
10	<input type="checkbox"/> 01.01.00 00:00	01.01.00 23:59	Holidays	<input type="checkbox"/>
11	<input type="checkbox"/> 01.01.00 00:00	01.01.00 23:59	Holidays	<input type="checkbox"/>
12	<input type="checkbox"/> 01.01.00 00:00	01.01.00 23:59	Holidays	<input type="checkbox"/>
13	<input type="checkbox"/> 01.01.00 00:00	01.01.00 23:59	Holidays	<input type="checkbox"/>
14	<input type="checkbox"/> 01.01.00 00:00	01.01.00 23:59	Holidays	<input type="checkbox"/>
15	<input type="checkbox"/> 01.01.00 00:00	01.01.00 23:59	Holidays	<input type="checkbox"/>
16	<input type="checkbox"/> 01.01.00 00:00	01.01.00 23:59	Holidays	<input type="checkbox"/>

Notes

- Check  to select active entries.
- Select "Annually"  to set repetitive switching points.
- Click [ Check ] to sort and check the data before saving.

System report

Path: Home > 0.2.150 OZW772.xx > Settings > System report

Note

- Enter these settings if the web server is to regularly send an e-mail for a fault.

Data point	Explanation, example		
Signal time Default val: 06:00 hh:mm Setting val: 00:00...23:59	The setting value corresponds to the time of day when a system report is sent (once every 24 hours).		
Message cycle Default val: 1 d (day) Setting val: 0...255 d	The setting value corresponds to the interval (in days) at which a system report is sent. The first system report is delivered after completion of the first message cycle and then as per the message cycle. The system report is disabled when the message cycle = 0.		
Priority Default val: Urgent Setting val: Urgent / Not urgent	Filter when sending the system reports. The setting "Urgent" sends the system report to all active message receivers. For setting "Not urgent" the system report is only sent to message receivers with a fault priority of "All".		

Next report Default val: 0 d (day) Setting val: 0...255 d	Waiting period until the initial system report is sent after commissioning (or re-commissioning) of the web server. The value can be exceeded when the starting point is to be modified.	<input checked="" type="checkbox"/>	—
---	--	-------------------------------------	---

## Consumption data

Web server provides consumption data functionality in the form of consumption data files. See Section 5 for additional information.

## Plant information

Path: Home > 0.2.150 OZW772.xx > Settings > Consumption data > Plant information

## Note





The settings set user defined data fields, section display and one centralized due date for the consumption data file.

Data point	Explanation, example		
Plant name Default val: (blank) Setting val: max. 20 characters	Web server or plant name.	<input checked="" type="checkbox"/>	—
Header Default val: (blank) Setting val: max. 49 characters	Header for consumption data file.	<input checked="" type="checkbox"/>	—
Information line 1...10 Default val: (blank) Setting val: max. 49 characters	The information lines are saved to the consumption file. They are freely applicable, e.g. to identify the send by post or internet address for the plant.	<input checked="" type="checkbox"/>	—
Footer Default val: (blank) Setting val: max. 49 characters	Footer consumption data file.	<input checked="" type="checkbox"/>	—
Delete meter replacem section Default val: No Setting val: No, Yes	Delete meter replacement section for consumption data file.	<input checked="" type="checkbox"/>	—
Due day date Default val: 31. December setting val: Jan 1...Dec. 31.	Centralized due day applicable to all WRI982 pulse inputs and for all M-bus meters. A due day on the M-bus meter that differs from this due day is ignored. The last or first day of the month is typically entered. The due day value is only transmitted on the third day of the month to the web server.	<input checked="" type="checkbox"/>	—
Send due day date Default val: Off Setting val: Off, On	Enable send of centralized due day.	<input checked="" type="checkbox"/>	—

Receiver Path: Home > 0.2.150 OZW772.xx > Settings > Consumption data > Receiver > E-mail receiver 1...2

- Notes 
- The settings configure sending the consumption data file per e-mail.
  - The e-mail signature (sender name, address, etc.) is set under "Settings > Communication > E-mail".
  - The settings are independent of the settings for the message receiver (Section Message receiver 1...4).

Data point	Explanation, example		
E-mail address Default val: mailReceiver@example.com Setting val: max. 49 characters	The setting must match the consumption data receiver's e-mail address.	<input checked="" type="checkbox"/>	<input type="checkbox"/>
Transmit interval Default val: Never Setting val: Never, daily, weekly, monthly	The send interval sets how often consumption data is sent to the e-mail receiver. The setting "Never" corresponds to "turned off".	<input checked="" type="checkbox"/>	<input type="checkbox"/>
File format Default val: .xml Setting val: (empty), .xml, .csv	The file format sets the format of the e-mail attached for consumption data. Two files are attached if both formats are selected. No file is added is the setting is empty.	<input checked="" type="checkbox"/>	<input type="checkbox"/>
Test receiver Default val: --- Setting val: ---, Trigger	"Test receiver" tests the connected to the selected receiver.	<input checked="" type="checkbox"/>	<input type="checkbox"/>



- Notes 
- On send interval:
- It is generally sent as soon as the data collection is completed for the web server.
  - Daily means between 5 and 10 am.
  - Weekly means Sundays (between 5 and 10 am).
  - Monthly refers to the third day of the month (between 5 am and 10 pm).

In the case of "Annual allocation", "monthly" can be selected: The 11 additional e-mails with attached consumption data files are available for backup purposes or to provide precise billing by the month in the event of a change of renters.

**Faults** Enter these settings if the web server is to send an e-mail for a fault.

Local Path: Home > 0.2.150 OZW772.xx > Settings > Faults > Local

Note  "Local" faults refer to web server faults.





Data point	Explanation, example		
Message triggering Default val: Coming Setting val: Coming, Coming and going	Coming: a message is triggered when a fault is received (start of fault). Coming and going: A corresponding message is triggered at start and end of fault. A web server fault displays the LED  .	<input checked="" type="checkbox"/>	<input type="checkbox"/>

System

Path: Home > 0.2.150 OZW772.xx > Settings > Faults > System





Note

 "System" faults refer to faults to the KNX device received via the KNX bus.

Data point	Explanation, example		
<b>Message triggering</b> Default val: Coming Setting val: Coming, Coming and going	Coming: a message is triggered when a fault is received (start of fault). Coming and going: A corresponding message is triggered at start and end of fault.  This "Message triggering" applies to device faults on the KNX network (system) including on the web server device list. LED  indicates a KNX device fault.		

Texts

Path: Home > 0.2.150 OZW772.xx > Settings > Texts

Data point	Explanation, example		
<b>Plant name</b> Default val: OZW772.01 OZW772.04 OZW772.16 OZW772.250 Setting val: max. 20 characters	User definable text for the plant displayed by web server and transmitted in the message.  Update note on menu texts => Update or regenerate web server device web page.		

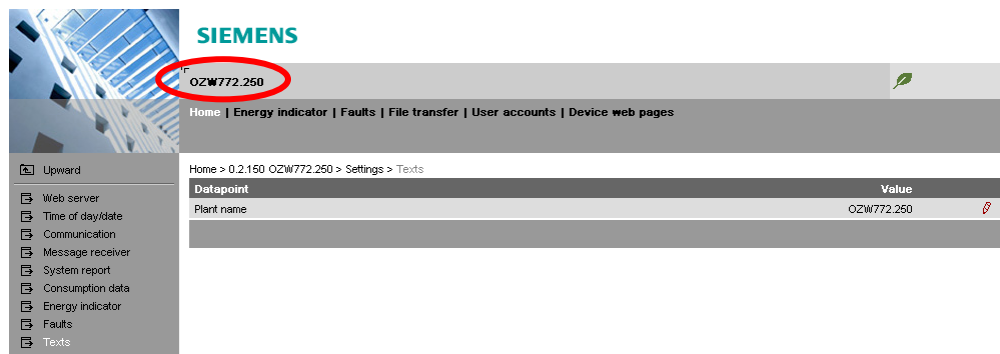

## 2.6 Commission network components

### Commission network components

The web server can be operated from a PC with web browser on a local area network (LAN) or via the Internet.

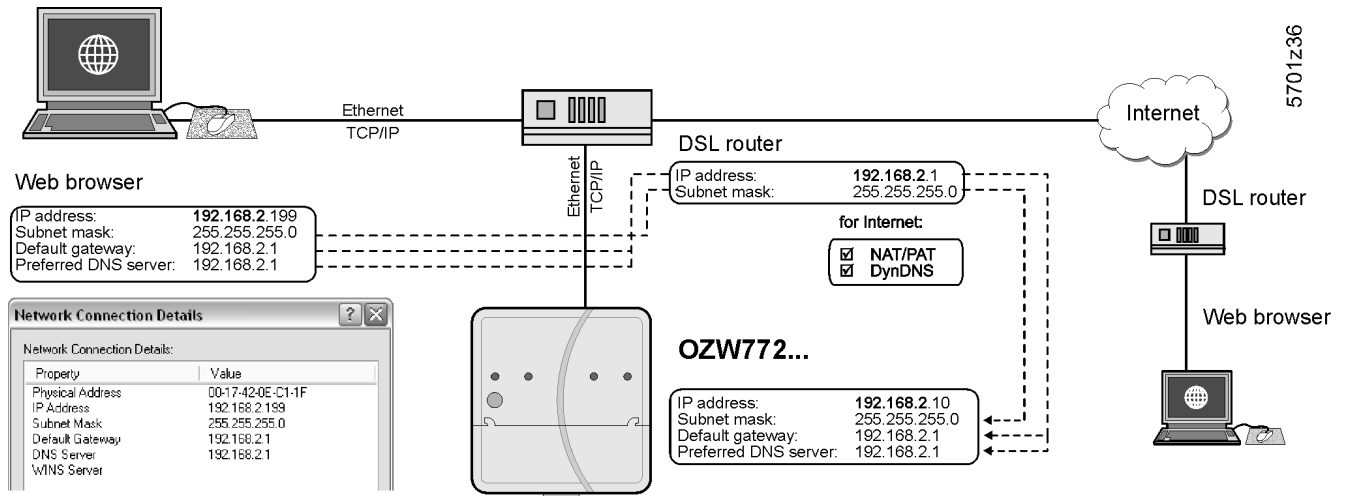

The illustration shows a typical application with operation via Internet and home network. Use can use "Network connection" to issue IP address, subnet mask, standard gateway and preferred DNS server if the PC is connected to the home network.

### 2.6.1 Operator station on a local area network (LAN)

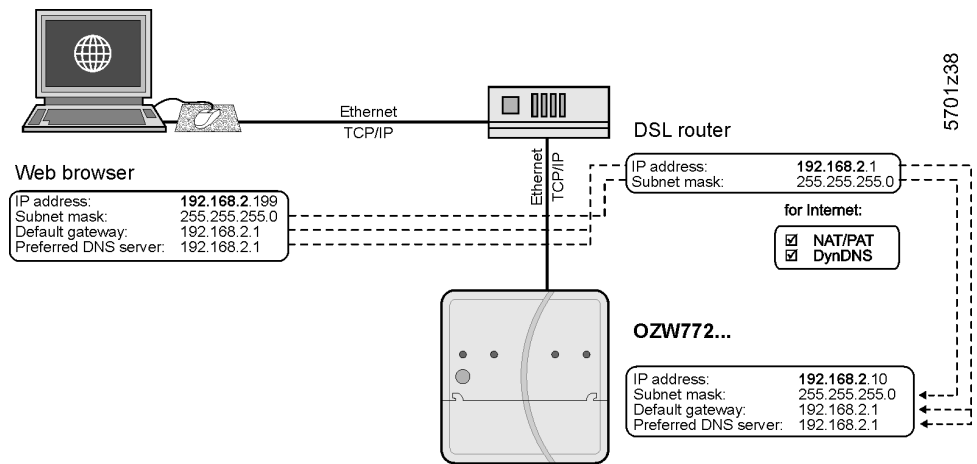

### Operator station

The operator station requires these settings, if the web server is operated from a PC with web browser on a local area network (LAN):

- IP address
- Subnet mask

### Note



Settings depend on network type and application. The different variants are described in Section 7.1.1.

## 2.6.2 Router

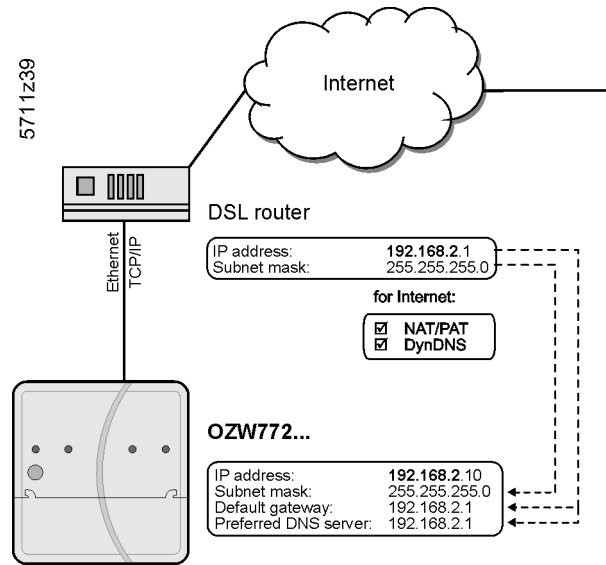

### Router

The router settings below are required, when:

- Accessing the web server from outside the local area network.
- A message is send via e-mail for a fault.

### Note

Remote access (e.g. DSL router with Internet connection) must be set up. A static IP address or DynDNS-capable controller with DynDNS account is prerequisite for operation via Internet.

Settings:

- NAT/PAT: Translate private parties on public IP addresses and ports.
- DynDNS: The dynamic IP address for the connection must be published if no fixed public IP address is available.
- Firewall: Access to the plant must be granted.

OZW used the following fixed ports:

- http (recommended on private networks only) 80
- https (recommended on public network 443
- ETS Tool 3671
- ACS Tool 50005
- ACS Offline Trend and FTP 21

Settings depend on network type and application. The different variants are described in Section 7.1.2.





## 2.7 Functional check

<b>Test condition</b>	Connections must be tested if all settings were made to the web server as well as to KNX devices.
LAN	A PC on the local network is used to test operations via LAN. The log in dialog box must appear after entering the local IP address for the web server (see Section 2.2.2).
Internet	We recommend using mobile participants with Internet access (Smart phone, mobile phone) to test operation over the Internet. The log in dialog box must appear after entering the public IP address or plant domain.

**Test message receiver** Path: Home > 0.2.150 OZW772.xx > Settings > Message receiver

- Notes**  • Do the test if the web server is to send a message or system report via e-mail for a fault.  
 • The test is also conducted if message suppression is switched on.

Data point	Explanation, example		
Test message receiver Default val: --- Setting val: Message receiver 1..4	Select a message receiver to test the connection to the receiver.	<input checked="" type="radio"/>	—
System report sent Display val: ---, Yes, No	The display changes from "---" after a few seconds to: "Yes": Message sent successfully "No": Message receiver not reached	<input type="radio"/>	—
Cause Display val: ---, Network cable, DNS setting, Address mail server, Port number mail server, E-mail address receiver, Authentication mail server See the following table.	"Cause" displays the results of "System report sent". For "Yes" the cause is "---". For "No" the cause is displayed. The first cause is displayed for multiple faults.	<input type="radio"/>	—
Message inhibition Display values: Yes, No	Shows the message suppression switch setting <b>(8)</b> (see Section 1.2).	<input type="radio"/>	—

**Cause: Cause of error and problem solution**

A specific cause can originate in different sources. The problem must be solved accordingly.

Cause	Cause of error	Solution
---	No error	---
Network cable	No network cable or no active network connected.	Connect cable or active network. LEDs must be lit at Ethernet connection.
DNS setting	DNS server could not be reached or no guaranteed network connection.	Check Setting DNS server, Default gateway, or network connection.
Address mail server	Address mail server not discovered by DNS server.	Check Address mail server, Default gateway, or network connection.

Table continued on next page

Cause	Cause of error	Solution
Port number mail server	Mail server refuses connection or does not answer.	Check Port number mail server. A company proxy server may block Internet connection.
E-mail address receiver	Invalid E-mail address.	Check E-mail address.
Authentication mail server	Mail server refuses connection. Inconsistent Mail server response. "Authentication mail server" contains different errors. Encrypted mail server (i.e. with TLS = Transport Layer Security) may not be supported.	Check "Authentication mail server = Yes" and user name and Password. An invalid "E-mail address sender" can also result in this error.

### Test e-mail receiver consumption data

Pfad: Home > 0.2.150 OZW772.xx > Settings > Consumption data > Receiver

Note



Do the test if the web server sends consumption data via e-mail.

Data point	Explanation, example		
Test receiver Default val: --- Setting val: ---, Trigger	"Test receiver" tests the connected to the selected receiver.	<input checked="" type="radio"/>	<input type="radio"/>
Consumption data sent Display val: ---, Yes, No	The display changes after a few seconds from "---" to Yes: Message sent successfully. No: Message receiver not reached.	<input type="radio"/>	<input type="radio"/>
Cause Display val: ---, Network cable, DNS setting, Address mail server, Port number mail server, E-mail address receiver, Authentication mail server.	"Cause" displays the results of "Test receiver". For "Yes" the cause is "---" For "No" the cause is displayed. The first fault is displayed for multiple faults.	<input type="radio"/>	<input type="radio"/>

## 2.8 Additional settings

### Hide devices

You can determine whether a device in the device list can be operated under "Home".

Procedure:

1. Select "Device web pages"
2. Select  the device you want to hide.
3. Click [ Hide ]

Device name	Device address	Device type	Serial no	State	Generated on
<input checked="" type="checkbox"/> OZW772.01	0.2.150	OZW772.01	00FD00FF020D	Generated	23.11.2009 09:44
<input type="checkbox"/> Device	0.2.246	RMU710B-1	00FD0001E8A4	Generated	25.11.2009 16:51

Add Delete Generate Hide

### Note





-  Click [ Generate ] again to show the device. This may have an impact on the display of any existing meters in the consumption data file (For details see Section 5.2, Sections replace meter and section Start value web server).

### Delete history

Path: Home > 0.2.150 OZW772.xx > Settings > Faults

### Note

-  We recommend deleting the history after you have completed commissioning.

Data point	Explanation, example		
Delete history Default val: No Setting val: Yes	Delete history of all events and messages.  Setting value "Yes" is a temporary state, i.e. the setting value automatically returns to "No" after ca. 2 seconds.		

## 2.9 Final steps

### 2.9.1 Check faults

#### Fault indication

The fault indicator displays the plant state.

#### Notes

 No faults may be pending after commissioning. Additional information on faults is available in Section 3.3.

#### No fault

The fault indicator remains green as long as no fault is pending.

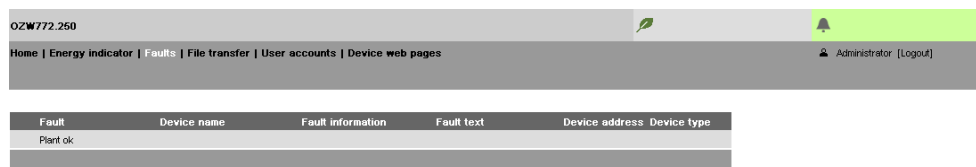

#### Fault

The fault indicator changes to red for faults. The most severe plant faults are displayed.

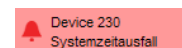

### 2.9.2 Final steps on web server







#### Final steps

The final function checks are conducted on the web server, the cover is mounted and the LEDs checked.

#### Note

 On display and operating elements, see Section 1.2.

Procedure:

1. Unplug USB cable.
2. Switch off message inhibition and address mode.
  - Switch 8 must be set to "Off" 
  - Address mode LED  must be off.
3. Mount terminal cover.
4. Press Remote  button for more than 6 seconds.
  - The web server sends a system report to the defined message receivers.
  - Fault LED  displays (flashing) error in establishing communications.
5. LED On  must be steady green.
6. Fault LED  must be off.



## 2.10 Supply state

---

### Restore default state

The web server can be reset to factory default settings. This is probably a good idea when using the web server for another plant.

Procedure:

1. Simultaneously press "Long" (> 6 seconds) on the "Remote" ✓ button and "Prog"   
The LED "On"  turns off. The web server restarts.
2. Wait until the web server is operational (LED "Run"  is green).

### Note



When restoring default state:

- All settings are reset to default state.
- Plant diagrams are deleted.
- The device list is deleted.
- Uploaded files are deleted.
- Unsent messages are deleted.
- History data is **not** deleted:  
It must be deleted manually (see Section 2.8).

### Note



The KNX device addresses and Ethernet IP address are also reset to default state.

## 2.11 Software updates

---

We differentiate between the following:

- System definition updates to integrate device descriptions of new devices in the web server.
- Firmware updates to update the web server to the latest firmware version. Firmware updates may also contain new device descriptions (system definitions).

### System data update

The web server supports a number of Synco devices and differentiates them via device descriptions. A text catalog with various languages contains all web server texts and device descriptions.

### Note



A system definition update is a simply operational step via web browser. See Section 3.4 for information on uploading system definitions.

### Firmware update

Local operations on web server required to update firmware. Procedures are communicated for any firmware update accordingly.

### Logo update

The logos can be customized.

# 3 Operate using a web browser

This section describes how to operate the web server and connected devices.

## 3.1 Overview

### Overview

The plant is operated via PC, smart phone or mobile phone with compatible web browsers via USB interface, LAN/Ethernet or Internet.

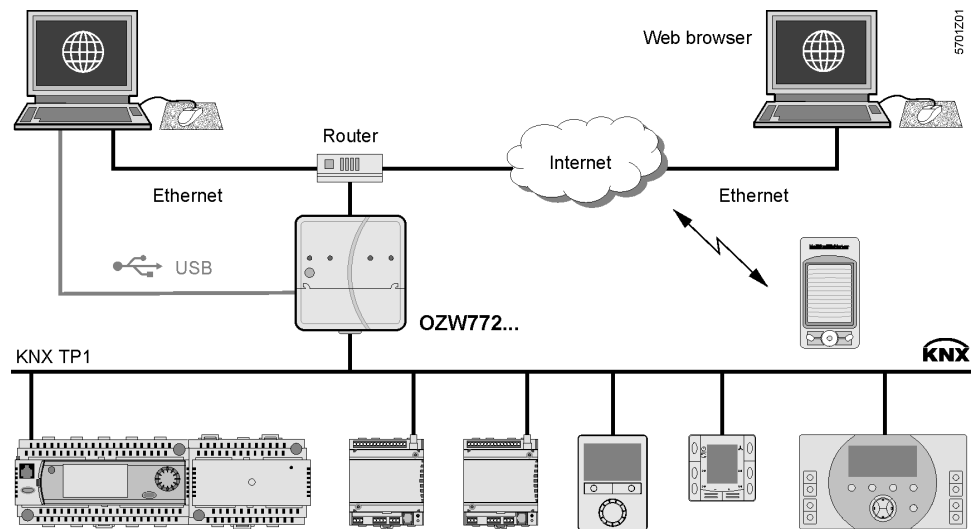

### Connection

Enter the IP address for the interface (USB, Ethernet) or the plant's domain name in the browser's address line.

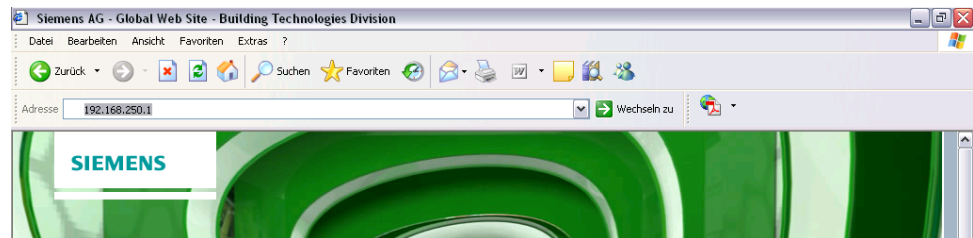

### Login

The login follows:

- User name
- Password

### Automatic log in

You can automate the process by adding the login information to the browser's address line.

Format: <IP address>/main.app?user=<User name>&pwd=<myPassword>

Example: [10.169.9.121/main.app?user=Administrator&pwd=myPassword](http://10.169.9.121/main.app?user=Administrator&pwd=myPassword)

### Logout

After closing the Browser a logout of web session is done after 15 Minutes.

"Deep link"

You can create and save a deep link to go to a sub-page without navigating. The easiest way to do this is to copy the URL for the desired subpage and replace the browser's session ID with user name and password.

Example

Original URL:

**http://192.168.250.1/main.app?SessionId=f9d53187-2868-4a6b-8b20-9eca4e859a4d&section=popcard&id=637&idtype=4**

Available as "Deep Link":

http://192.168.250.1/main.app?**user=Administrator&pwd=myPassword&section=popcard&id=637&idtype=4**

The current, valid login information must be included for syntax "user=<user name>&pwd=<myPassword>".

## 3.2 Operate the plant

### Operate the plant

Device ready to operate are display via "Home".

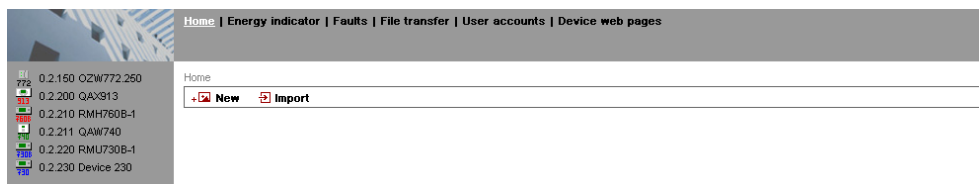

### 3.2.1 Operate Synco device

#### Operate Synco devices

Select the device in the left part of the menu to operate KNX devices. Web server displays the top level of the menu tree. From here, you can go to all operating pages and data points.

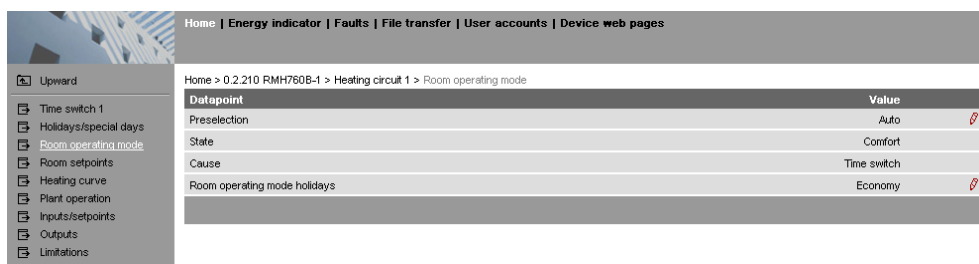

Operation of devices integrated via KNX S-Mode with ETS (Light, blinds, meters, etc.), is described in Section 9.2 "Operation KNX S-mode".

### 3.2.2 Operate web server

#### Operate web server

Click the left menu pane to select web server operation. Web server displays the top level of the menu tree. From here, you can go to all operating pages and data points.

KNX pages defined with ETS are also displayed here.

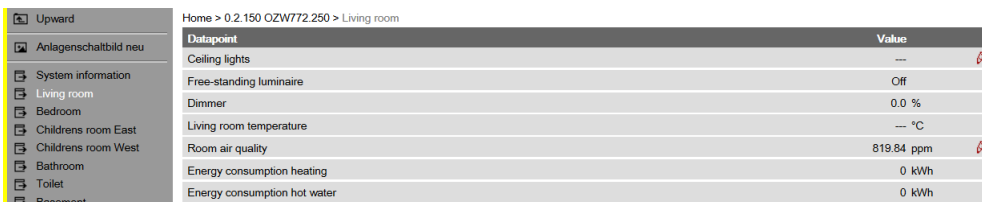



## Switch views

Only the following parts of the user interface are displayed to operate the web server from a smaller screen or to hide navigation:

- Plant state
- Plant name
- Display

The double arrow in the upper left-hand corner switches the view.

Full screen

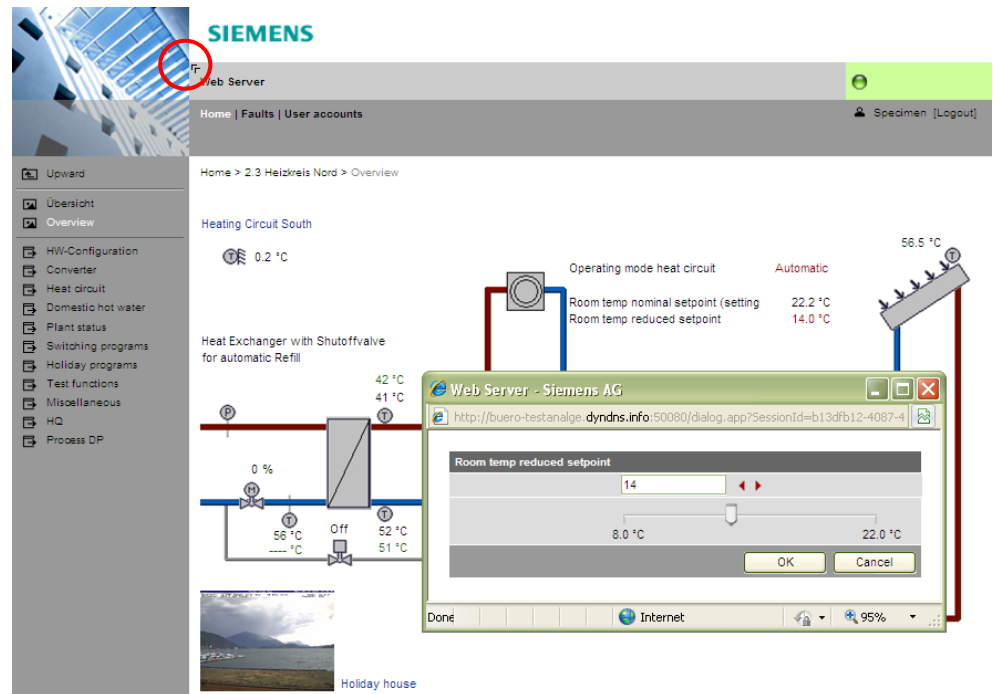

Partial screen

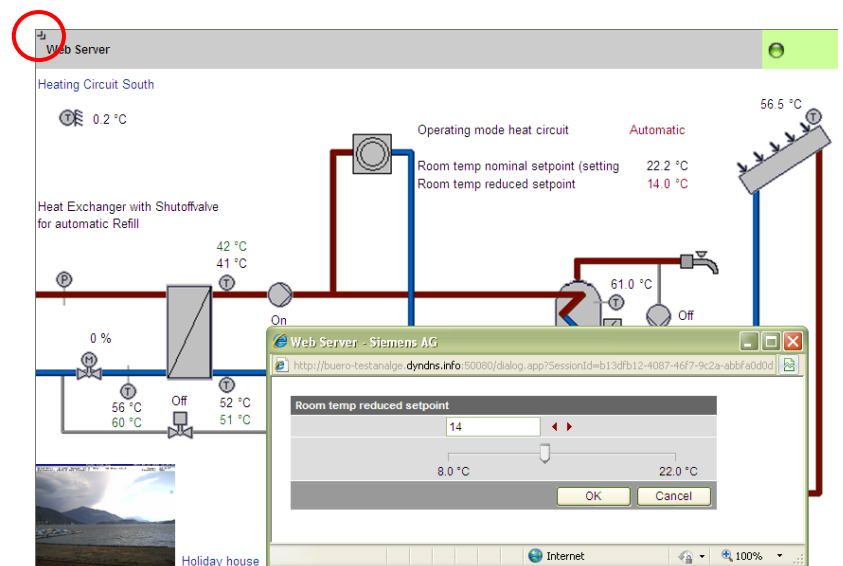

Note



In partial view, navigation to other plant web pages must be implemented using user-defined links. You can return to the full view at any time for navigation.

### 3.2.3 Web server diagnostics



#### Diagnostics

The following information is required to identify product version and settings. Information on faults is available in Section 3.3.2.

#### Web server

Device information on the web server helps identify the web server.



Path: Home > 0.2.150 OZW772.xx > Device information > Web server.

Data point	Explanation, example		
Plant name	Web server or plant name.	<input type="radio"/>	<input type="radio"/>
Web server type	Web server product number (ASN).	<input type="radio"/>	<input type="radio"/>
Fabrication number	Device number from production	<input type="radio"/>	<input type="radio"/>
Software version	Web server software version.	<input type="radio"/>	<input type="radio"/>
Build	Revision status for the software.	<input type="radio"/>	<input type="radio"/>
Hardware version	Web server hardware version.	<input type="radio"/>	<input type="radio"/>
Message inhibition	Displays position of switch 8 "Message inhibition"	<input type="radio"/>	<input type="radio"/>

#### KNX

The following information displays the current settings and states on the KNX bus.



Path: Home > 0.2.150 OZW772.xx > Device information > KNX.

Data point	Explanation, example		
Area	First KNX network level. The line coupler assigns the area. The factory setting for the web server is set to area 0.	<input type="radio"/>	<input type="radio"/>
Line	Second KNX network level. The line coupler assigns the line. The factory setting for the web server is set to line 2.	<input type="radio"/>	<input type="radio"/>
Device address	The factory setting for the web server is set to device address 150.	<input type="radio"/>	<input type="radio"/>
Clock time mode KNX	"Master" or "Autonomous": Time is mapped from web server quartz. "Slave": the web server gets the time from the master clock.	<input type="radio"/>	<input type="radio"/>
Clock slave remote adj KNX	"Clock slave remote adj KNX" = "Yes" allows the web server to change the clock master time on the KNX network. "Yes" makes sense for "Time synchronization" = "Slave on bus".	<input type="radio"/>	<input type="radio"/>
Number of devices max	Maximum possible number of devices monitored by web server on the Synco bus.	<input type="radio"/>	<input type="radio"/>
Number of devices current	Actual number of devices monitored by web server on the Synco bus.	<input type="radio"/>	<input type="radio"/>
Last change	Time of last change to device list.	<input type="radio"/>	<input type="radio"/>

## Ethernet

You can consult the following information as needed to analyze problems on the Ethernet. It displays the current settings for the subnet.

Path: Home > 0.2.150 OZW772.xx > Device information > Ethernet.

Data point	Explanation, example		
IP address	Web server IP address. The factory IP address for the web server on the Ethernet is: <a href="#">192.168.2.10</a>	<input type="radio"/>	<input type="radio"/>
Subnet mask	The subnet mask defines the size of the subnet. A value of 255 masks the partial network; a value of 0 masks the device portion of the IP addresses on the subnet. Devices must have the same partial network to communicate directly. The web server has a default subnet mask <a href="#">255.255.255.0</a>	<input type="radio"/>	<input type="radio"/>
Default gateway	The standard gateway connects the subnet for the web server to additional networks, e.g. the Internet. The router typically is the default gateway.	<input type="radio"/>	<input type="radio"/>
Preferred DNS server	Preferred DNS server required to send e-mails. The router is typically the DNS server as well for the web server.	<input type="radio"/>	<input type="radio"/>
Alternate DNS server	An alternative DNS server is only defined for redundant systems and is typically empty.	<input type="radio"/>	<input type="radio"/>
Physical address	The physical address (MAC address) is a unique identification for the Ethernet interface.	<input type="radio"/>	<input type="radio"/>

## 3.3 Faults

### 3.3.1 Overview

#### Fault overview

The "Faults" function displays the most severe fault on a Synco device in the device list. It is available to all user levels. The following information helps identify the fault:

- Fault
- Device name
- Fault information (date, time, fault code).
- Fault text
- Device address
- Device type

Fault	Device name	Fault information	Fault text	Device address	Device type
 Fault 1	Device	30.11.2009; 13:27; 3920	Frost	0.2.246	RMU710B-1

#### Notes



- An overview of web server faults is available in Section 10.2.1.
- Faults for Synco devices are listed in the documentation for the corresponding devices.
- Click  to go to the corresponding device's web operation.



### 3.3.2 Device faults

You can display detailed information on all faults via the "Home" menu.

#### Local faults

Displays all faults for the OZW772.

Path: Home > 0.2.150 OZW772.xx > Faults current > Local



Data point	Explanation, example		
Fault 1..10	Displays for each fault: <ul style="list-style-type: none"> <li>• Fault information (date, time, fault code).</li> <li>• Fault text</li> </ul>	<input type="radio"/>	<input type="radio"/>
Acknowledge faults Default val: No Setting val: Yes / No.	The setting value "Yes" acknowledges web server faults (same effect as "Remote" ✓). Setting value "Yes" is a temporary state, i.e. the setting value automatically goes to "No" after ca. 2 seconds.	<input checked="" type="radio"/>	<input checked="" type="radio"/>

Datapoint	Value
Fault 1	
Fault information	07.01.2005; 15:47; 5000
Fault text	No bus power supply
Fault 2	
Acknowledge faults	No 

## System faults

The most severe faults are displayed for each device on the KNX bus.

Path: Home > 0.2.150 OZW772.xx > Faults current > System > Fault 1...n

Data point	Explanation, example		
Fault 1..n	Displayed under "Fault 1..n": Device name, Fault information, Fault text, Area, Line, Device address, Device type	<input type="radio"/>	<input type="radio"/>

Note

 Faults for Synco devices are listed in the documentation for the corresponding devices.

## 3.4 File transfer

"File transfer":

- Downloads consumption data
- Download message history as Excel or text file
- Upload documents to the web server
- Upload logos
- Upload system definitions

### Create and manage trend functions

Creating and managing trend functions is described in Section 8 "Trend functions".

### Download consumption data

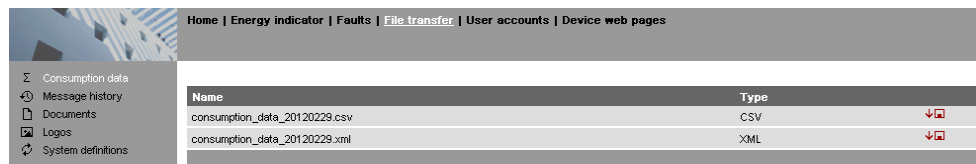

The screenshot shows a web interface with a breadcrumb trail: Home | Energy indicator | Faults | File transfer | User accounts | Device web pages. On the left, there is a navigation menu with options: Consumption data, Message history, Documents, Logos, and System definitions. The main content area displays a table with two columns: 'Name' and 'Type'. The table contains two rows of data, each with a download icon to its right.

Name	Type
consumption_data_20120229.csv	CSV
consumption_data_20120229.xml	XML

### Note

 The file can also be sent by e-mail, in addition to the download of consumption data described here.

Proceed as follows:

1. Select File transfer in primary navigation.
2. Click  depending on the desired output format for CSV or XML. The file download dialog box is displayed.
3. Open the file with the application or save it to any location.

### Notes

-  • The consumption data file is mapped at the moment it is opened.
- The CSV is suitable for processing using any program that work with comma separated data.
- The XML format is suitable for processing with MX Excel or Excel-compatible programs.

The design of the allocation file is explained in Section 5.

### Download message history

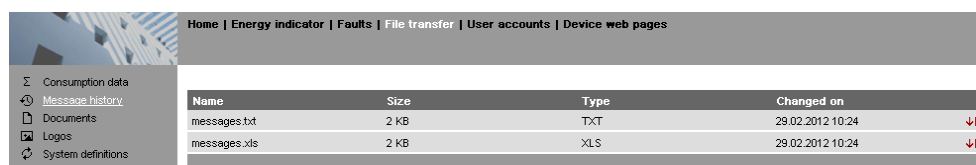

The screenshot shows a web interface with a breadcrumb trail: Home | Energy indicator | Faults | File transfer | User accounts | Device web pages. On the left, there is a navigation menu with options: Consumption data, Message history, Documents, Logos, and System definitions. The main content area displays a table with four columns: 'Name', 'Size', 'Type', and 'Changed on'. The table contains two rows of data, each with a download icon to its right.

Name	Size	Type	Changed on
messages.txt	2 KB	TXT	29.02.2012 10:24
messages.xls	2 KB	XLS	29.02.2012 10:24

Procedure:

1. Select "Message history" from secondary navigation.
2. Click  for the desired document. TXT for text or ASCII format and XLS for Excel format. The "File download" dialog box opens.

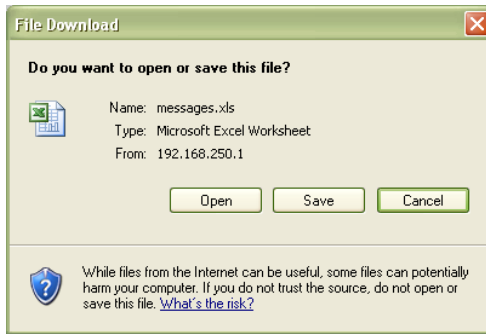

3. Open the file with the application or save it to any location.

## Notes



- Message history export is available to administrator and service user levels.
- The message history remains intact when resetting the web server to default.

## History data

The message history includes the last 500 events on faults, fault messages, and system reports. It contains the following information:

- Plant information:
  - Plant name
  - Phone number plant (Unused)
- Information per entry:
  - Event
  - Plant section (Device name (KNX bus address))
  - Date of occurrence
  - Time of occurrence
  - Fault code+text
  - Transmission date
  - Transmission time
  - Message receiver
  - Cause

Plant name	OZW772.01							
Phone number plant								
Event	Plant section	Date of occurrence	Time of occurrence	Fault code+text	Transmission date	Transmission time	Message receiver	Cause
Fault going	OZW772.01 (0.2.150)	'2009.06.24	'15:42:26	5003: Invalid time of day				
Message not OK	OZW772.01 (0.2.150)	'2009.06.24	'15:42:26	5023: M'rec 1 not reached	'2009.06.24	'15:42:38	1: myservice@siemens.com	Fault receiver
Message not OK	OZW772.01 (0.2.150)	'2009.06.24	'15:42:26	5023: M'rec 1 not reached	'2009.06.24	'15:42:43	1: myservice@siemens.com	Fault receiver
Fault going	OZW772.01 (0.2.150)	'2009.06.24	'15:46:29	5023: M'rec 1 not reached				
Fault coming	OZW772.01 (0.2.150)	'2009.06.24	'16:20:30	5001: System time failure				
Fault coming	Appartment Unit (0.2.100)	'2009.06.24	'16:57:29	5031: Radio comm error				
Fault coming	Appartment Unit (0.2.100)	'2009.06.24	'17:27:10	5031: Radio comm error				
Fault going	Appartment Unit (0.2.100)	'2009.06.24	'17:35:57	0: No fault				
Fault going	OZW772.01 (0.2.150)	'2009.06.24	'17:47:25	5001: System time failure				
Message not OK	OZW772.01 (0.2.150)	'2009.06.26	'16:10:54	OK	'2009.06.26	'16:11:09	1: myservice@siemens.com	Fault receiver
Fault coming	OZW772.01 (0.2.150)	'2009.06.26	'16:15:42	5000: No bus power supply				
Fault going	OZW772.01 (0.2.150)	'2009.06.26	'16:16:52	5000: No bus power supply				

## Upload documents

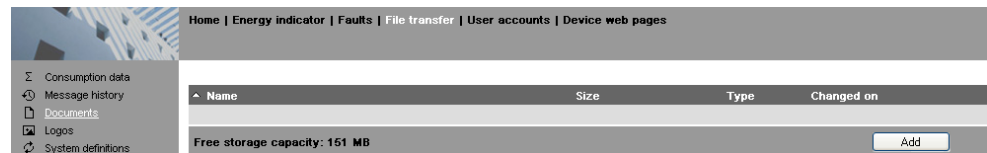

Procedure:

1. Click [ Add ] and select [ Find ]



2. Select desired file.
3. Click [ Upload ] to finish.

## Notes



- Make sure there is enough memory for uploading.
- The Administrator and Service levels allow for uploading documents.

## Upload logos

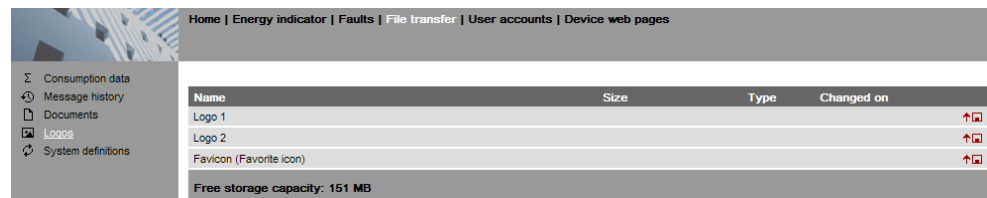

Procedure:

1. Select l from secondary navigation.
2. Save existing logo(s) as needed (see below).
3. Click



4. Select the desired file.  
Adhere to maximum dimensions (see Notes).
5. Click [ Upload ]
6. Re-load page content from web server (Internet Explorer, Firefox: Ctrl+F5; i.e. no older data is displayed from the browser cache)

Save logos:

1. Click "Logo 1" or "Logo 2". The browser window opens with the logo.
2. Right-click the log and save to the desired location via "Save Image As".

## Notes



- Log file transfer is available to administrator and service user levels.
- Allowed file formats: PNG, GIF, JPG, BMP.
- The left logo (Logo 1) has max. 625 x 54 pixels.
- The right logo (Logo 2) has max. 200 x 54 pixels.
- The original logos are restored when resetting the web server to default.
- The area belonging to the logo is highlighted in color when the cursor moves within the display area above the logo line.



## Upload system definitions

Name	Current version	Minimum version	Changed on
System definitions	2.1.0	2.1.1	23.02.2012 10:58

Free storage capacity: 151 MB Update

Procedure:

1. Select System definitions from secondary navigation.
2. Click [ Update ]

Add

Browse...

Upload Cancel

3. Select the desired file.
4. Click [ Upload ] to finish.
5. Restart web server with power-down, power-up.
6. You must recreate the devices following a system definition upload.

Notes



- System definition file transfer is available to administrator and service user levels.
- Uploading and installing make take more than 5 minutes.

System definitions

System definitions comprise:

- Device descriptions.
- Text catalogs in each user language.
- Units catalog.

The device web pages use the uploaded system definitions to properly display devices and menus.

You must generate all device web pages following successful uploading. This applies the new system definitions.

The system definitions must be compatible with the web server's software version. If incompatible, an associated message is displayed and the old system definitions remain as is.

**Note**



Make sure there is at least 60 MB free memory on the web server when uploading. If not, check the contents via File transfer > Documents.

## 3.5 Operation with ACS790

---

The following functions are available with ACS790:

- Commissioning with device search.
- Popcard.
- Plant diagrams:  
For standard applications for the Synco devices, web-capable plant diagrams may be exported from ACS790 and import them to the web server.
- Parameterization:  
Read and write parameter sets.  
(the parameter set of the OZW772 contains the device list of the OZW772, too)
- Commissioning protocol.
- Offline trend.

For more details, see data sheet N5649.

# 4 Visualize plants

## 4.1 Overview

---

Web server OZW772... visualizes technical equipment in buildings (HVAC, electrical, energy values) via plant web pages. The plant is operated and monitored via one or more generated plant web page(s).

**Download plant diagram** Web-capable plant diagrams can be downloaded from the HIT (HVAC Integrated Tool by Siemens) online platform for Synco 700 devices, RXB/RXL room controllers and RDG/RDF/RDU room thermostats standard applications.

**Create own plant web pages** You can freely design plant web pages.  
As a hybrid form, you can also modify and extend downloaded plant diagrams.

**Web page elements** Plant web pages are designed with the following web page elements:

- Background image
- Data point elements
- Text elements
- Link elements
- Partial pictures

Data point elements are used to operate and monitor read and write values for devices connected via KNX and the web server.

**Edit / view mode** Plant web pages are generated online in the web browser.  
The web page designer with administrator rights also switches the plant web pages to edit mode.  
Other users can query and operate the last saved visualization during the transition phase.  
Plant web pages return to view mode once the changes are saved. The new state is now available online at this point.

## 4.2 Example of a plant web page

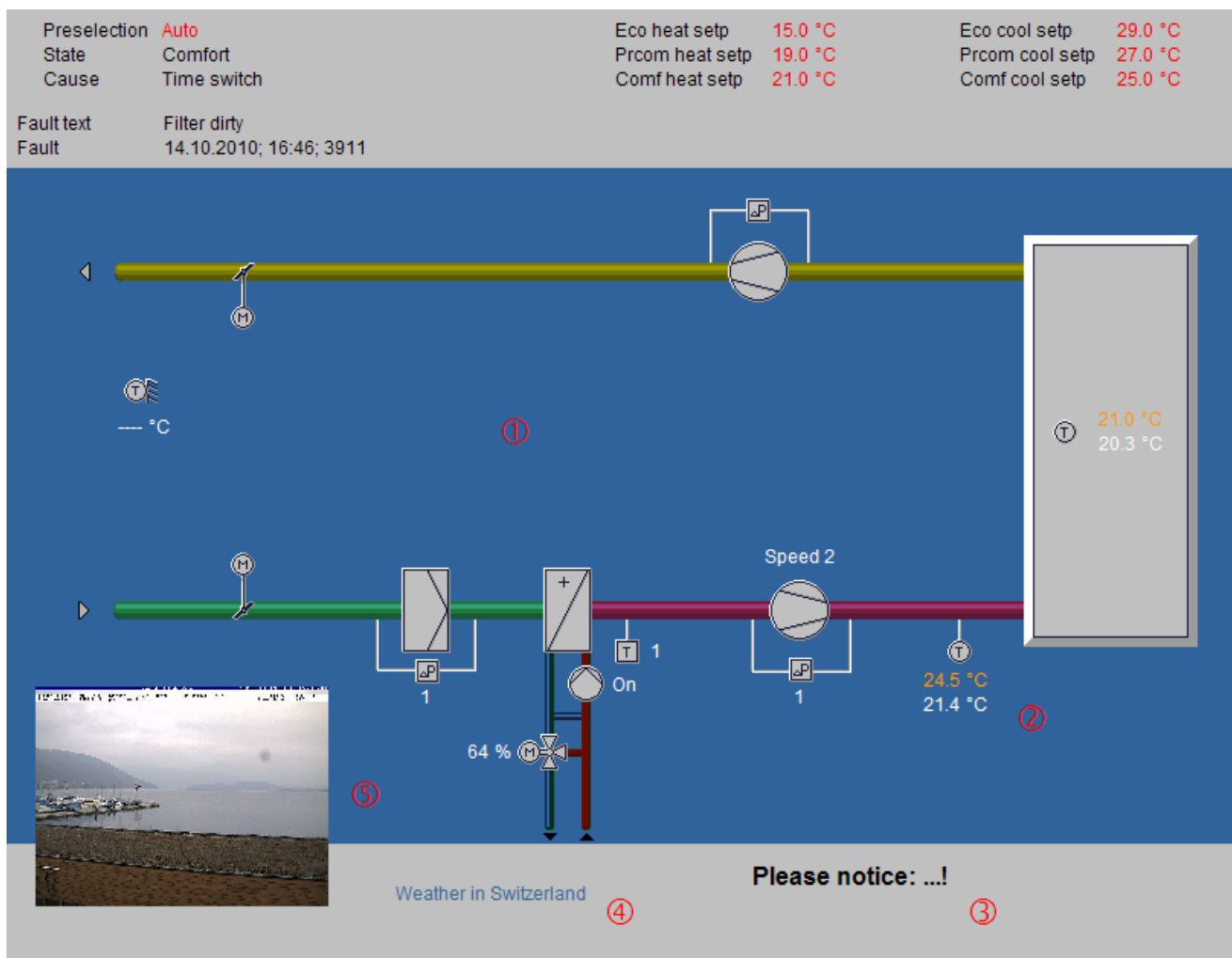

- ① **Background image** All surfaces, symbols and the diagram.
- ② **Data point element** Two data point elements: Present supply air setpoint (orange), supply air actual value (white).
- ③ **Text element** Explanation text.
- ④ **Link element** Link to Internet.
- ⑤ **Part. pic. element** Integrated web cam image.

The example above is an extension to a web-capable plant diagram downloaded from HIT.

The extension consists of additional, explanatory text (3), a link to the Internet (4) and an integrated web cam image (5), that is updated periodically (every minute).

As of OZW version 5.0, data points are also available on devices integrated via KNX S-Mode for display on the plant diagram (Light, blinds, energy volume meters, etc.). See Section 9 "KNX S-Mode".

## 4.3 Plant web page features

---

### Background image

A plant web page has an expandable area that can be used to place web page elements. The display area has a minimum size of 800px (width) and 580px (height).

The minimum display area is filled with a transparent background image if no background image is explicitly selected.

- The display area can be expanded to any size by adding a larger background image.
- The following types are accepted: png, jpg, gif and bmp; we do not recommend using bmp due to the file size.

### Position in secondary navigation

Multiple plant web pages are listed from top to bottom in the secondary navigation per their "Position". The plant web page is built and displayed at "Position"=1 when going to a home or device node. Use "Position > New > Properties" to set the "Position" in the secondary navigation or "Properties > Position" for existing plant web pages.

### Front side / Background

The following applies to levels within a plant web page:

- The background picture is located in the background.
- The group of partial pictures are in front.
- The group with all remaining elements are in front.
- More recently added elements are on top of previously added elements within the group of partial pictures and remaining elements.

Please note the following for the last statement:

- If **an** element is deleted as part of editing and another element added, the new element jumps to the level of the deleted one. This level is not always the top level.
- You must add a new element as part of **new** editing to ensure that the new elements are placed at the top (finish with OK and re-click edit).

### Show / Hide

Plant web pages are hidden for a hidden device with appended plant web pages. The associated plant web pages are displayed again if the device is re-generated and displayed (Important note in Section 2.8).

### Delete

Appended plant web pages are irretrievably deleted once a device is deleted. The same is true when you reset the web server.

### Changes to controller configuration

Any change to the controller configuration creates differences between the controller and the mapping on the web server. This impacts plant web pages as well where data point elements access the controller via the web server map. You must run "Generate" each time you change the controller configuration (see Section 2.4 for workflow).

### Key variables

Any number of plant web pages per web server are possible.

- The web server has 180 MB in memory.
- You should pay special attention to image file size to save memory; (current available memory is available at "File transfer > Documents").
- A maximum of 100 elements may be added on a plant web page from one web page element type (e.g. a maximum of 100 data point elements).

## 4.4 Toolbar

### Note

The menus described below are only displayed and operable on the "Administrator" user level.

### View mode, no web page available

The following toolbar is displayed at home and on the device nodes, if no plant web pages are generated:

Home > 0.2.150 OZW772.16



Menu	Description (in German)
New	Create new plant web page.
Import	Import archived plant web page. Plant web pages are archived and imported as .tar files.

### View mode, web page available

The toolbar is as follows for an existing plant web page:

Home > RMU710B\_A01\_ADA001BHQ



Menu	Description (in German)
Properties	Properties dialog for the plant web page. Enter the same as for "New". Furthermore, "Replace datapoint addresses" address identical data points on another device (KNX address).
New	Create another plant web page.
Import	Import archived plant web page.
Edit	Switch to edit.
Copy	Copy selected plant web page to another device node.
Export	Export selected plant web page as .tar archive.
Delete	Deleted selected plant web page.

### Edit

Click Edit to switch the plant web page to edit mode. The toolbar is as follows:

Home > RMU710B\_A01\_ADA001BHQ



Menu	Description (in German)
Datapoint	Embed data point element to web page. A data point element consists of two fields: – Data point value for a device connected via KNX or the web server. – Data point text.
Text	Add free text (single line) to plant web page. The text is entered in the field "Displayed name".
Link	Hyperlink to other plant web pages, to a document or an external web page.
Partial picture	Add additional picture to plant web page. "Link external" integrates periodically updated, external images (e.g. web cams).

### User levels

Only an administrator may generate and change visualization. User levels have the same rights for operation and monitoring.

## 4.5 Import web-capable plant diagrams

HIT has web-based plant diagrams for download and import to the web server for Synco 700 standard applications as well as the room controllers RXB and RXL.

### Prerequisites

- The drafter is logged on to the web server as an administrator.
- The web server is connected via KNX with one or more devices (Synco 700 devices, room controllers).
- A standard application is loaded on the device.
- The device web page is generated, see Section 2.4. The web server menu tree and data point information for the device and the loaded standard application are now available.

### Download plant diagram from HIT

Workflow in HIT online platform (Siemens HVAC Integrated Tool):

1. Run [www.siemens.com/hit](http://www.siemens.com/hit).
2. Select country.
3. Select "Applications" in HIT.

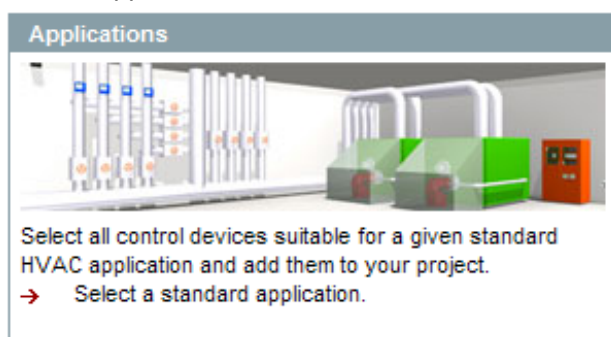

4. Select application (heating, ventilation/air conditioning, refrigeration, rooms).
5. Select a standard application for the Synco 700 series (e.g. ADA001 U1B HQ) or a room controller application (RXB, RXL) in the "Rooms" application.
6. Click document symbol in the "Doc" column.

Application no.	Doc
A00001 MS0 HQ	
A00001 S0B HQ	
ADA001 U1B DE	
<b>ADA001 U1B HQ</b>	
ADA002 U1B HQ	

The dialog "Application documents" is displayed.

7. Click the ZIP symbol on the line "Plant diagram for operator station (ACS and OZW)".

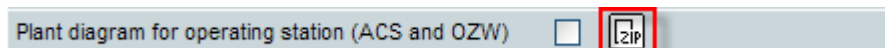

The file download dialog box is displayed.

8. Click Open.  
The ZIP program opens the ZIP archive.
9. Drag and drop the .tar file to the computer.
10. Close ZIP archive and HIT download dialog box.  
This saves the .tar file with the web-based plant diagram on the computer.

## Import plant diagram to web server

Workflow on web server:

1. Start at the home node in secondary navigation, select the Synco controller.
2. Click Import.  
The import dialog ("file name (\*.tar)") is displayed.
3. "Search..." to go to the .tar file saved on the computer.
4. Click Open.
5. Click Upload.  
Import information is displayed while the file is being read; the property dialog box now opens.
6. Check "Replace datapoint addresses".
7. From the dropdown menu, select the KNX address for the controller connected via KNX and used to load the standard application.

Properties		
Displayed name	RMU710B_A01_ADA001BHQ	
Background picture	RMU710B_A01_ADA001_U1B_HQ.PNG	
Position	1	
Replace datapoint addresses		
0.2.253	<input checked="" type="checkbox"/>	0.2.250

8. Click [ OK ] to start.  
The plant diagram is finished.

## Result

The controller or plant can now be operated and monitored via the web-based plant diagram. The default display is as follows:

- Operating values (e.g. operating mode Auto, Comfort, PreComfort, etc.) is displayed in red. The cursor changes to a hand symbol when you move it over the display. Click to open the applicable settings dialog box.
- Set points are displayed in orange; actual values in white.

## Note

It may occur that individual data points for controllers cannot be mapped to the standardized plant diagram due to compatibility issues.

- The data point text "Data point not found" is displayed.
- Three question marks "???" are displayed as the data point value.

See Section 4.6 for any post editing.



## 4.6 Create own plant web pages

---

You can generate complete plant web pages yourself. As an option, you can change and extend any imported plant diagrams (see Section 4.5) as needed. This section presents the steps required to generate and design a customized plant web page.

### Prerequisites

- The drafter is logged on to the web server as an administrator.
- The web server is connected via KNX with one or more devices.
- The device web pages for the web server and devices are generated, see Section 2.4. The web server menu tree and data point information is now available.

### Create plant web page

The following describes how to create a plant web page and add a background image.

1. Go to home nodes or to a device node.
2. Click New.  
The properties dialog box is displayed.
3. In the Displayed name field, enter the name for the plant web page (is displayed later in the navigation area for the web server).
4. Click the red pencil in the Background picture field.  
The add dialog box is displayed.
5. Search to go to the desired background picture.
6. Click Open.
7. Click Upload.  
The file name for the selected picture is displayed in the background picture field.
8. Click OK.  
The plant web page is now saved with the background picture.

### Add data point element

The following describes how to add a data point element to a newly created plant web page.

1. Click Edit.  
The plant web page switches to edit.
2. Click Datapoint.  
The data point dialog box is displayed.
3. Click the red pencil in the Datapoint address field.  
The data point address dialog box is displayed.
4. Go to the data point via device, menu text(s).
5. Select Datapoint.  
The entire data point path is entered in the data point address field.
6. Set the X/Y position for the data point field in the display area.
7. Modify formats such as text field size for "Datapoint - value" and "Datapoint - text" as needed.
8. Click Apply to check the results of the change in formatting as a preview to the plant web page.
9. If satisfied, click OK to finish.
10. Click OK to change to view.  
The data point value was read and is displayed.

## Notes

- Double-click the data point element in edit to reopen the settings dialog box for an already created data point element. The data point element can also be deleted in the settings dialog box.  
This note applies as well to other web page elements.
- As an alternative to setting the X/Y position in the data point dialog box, you can also position data point elements using drag and drop in edit mode. The element can no longer be moved after switching to view mode. This note applies as well to other web page elements.
- The X/Y position in the data point dialog box is anchored to the text in the data point value field and its alignment. In conjunction with the alignment functions, the data point field moves to the right for left align and to the left for right align (see the following graphic).  
This note refers as well to text and link elements accordingly.

### Alignment

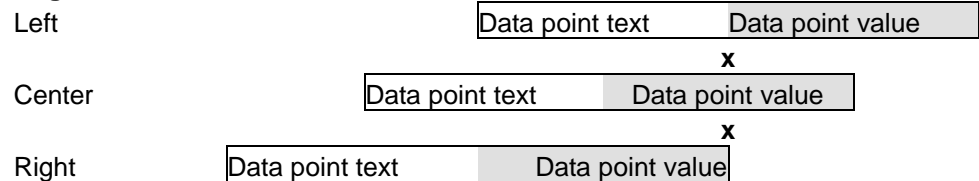

## Notes

- The "x" displays the changed position of the anchor.
- The alignment of all the data point texts is left aligned.

## Add text element

The following describes how to add informational text to a plant web page.

1. Click Edit.  
The plant web page switches to edit.
2. Click Text.  
The text dialog box is displayed.
3. Enter the desired text in the Displayed name field.
4. Set the X/Y position for the text field in the display area.
5. Format as needed.
6. Click Apply to check the results of formatting in a preview.
7. If satisfied, click OK to finish.
8. Click OK to change to view.

## Notes

Text elements are single lines.

Only a limited number of fonts are available for texts:

- Small 10pt
- Normal 12pt
- Large 16pt
- XL 24pt

## Add link element

The following describes how to add two lines to the plant web page:

- To another plant web page.
- To an external web page.

The link to a document is not displayed, but works accordingly.

### Link to another plant web page

1. Click Edit.  
The plant web page switches to edit.
2. Click Link.  
The link dialog box is displayed.
3. Enter the desired text for display in the Displayed name field.
4. Select Link to in the "Plant diagram" field.
5. Click the red pencil in the same field.  
The plant diagram dialog box is displayed with all plant diagrams available on the web server.
6. Select the desired plant diagram.  
Enter the path for the plant diagram in the "Link to" field.
7. Set the X/Y position for the link field in the display area.
8. Format the link as needed.
9. Click Apply to check the results of formatting in a preview.
10. If satisfied, click OK to finish.
11. Click OK to change to view.  
The link is enabled immediately in the view mode: Click to open the corresponding plant web page.

### Tip

We recommend adding a link on the target web page to return to the previous page.

### Notes

- Links are broken after importing a plant web page to another web server and must be restored per the instructions above.
- The links to other plant web pages are also broken after a firmware update for web pages exported in advance and then imported and must be restored per instructions above.

### Links to an external web page

1. Click Edit.  
The plant web page switches to edit.
2. Click Link.  
The link dialog box is displayed.
3. Enter the desired text for display in the Displayed name field.
4. Select external link in the Link to field.
5. Click the red pencil in the same field.  
The link external dialog box is displayed.
6. Enter the desired URL.
7. Check the correctness of the entry: The Internet page is opened.
8. Confirm with OK.
9. Enter the URL in the "Link to" field.
10. Format the link as needed.
11. Click Apply to check the results of formatting in a preview.
12. If satisfied, click OK to finish.
13. Click OK to change to view.  
The link is enabled immediately in the view mode: Click to open the corresponding web page.

## Add partial picture

The following describes how to add two partial pictures to the plant web page:

- A static picture downloaded to the web server.
- A link to an external picture on a server, e.g. continuously updated images from a webcam.

## Static partial picture

1. Click Edit.  
The plant web page switches to edit.
2. Click Partial picture.  
The partial picture dialog box is displayed.
3. Select "Picture source" in File field.
4. Click the red pencil in the same field.  
The add dialog box is displayed.
5. Click Search.
6. Go to desired image file.
7. Click Open.
8. Click Upload.  
Enter the file name for the selected image in the Field Source field.
9. Adapt Position and Scaling.
10. Click Apply to check the results of formatting in a preview.
11. If satisfied, click OK to finish.
12. Click OK to change to view.

## Dynamic partial picture

1. Click Edit.  
The plant web page switches to edit.
2. Click Partial picture.  
The partial picture dialog box is displayed.
3. Select "Picture source" in Link external field.
4. Opens the web cam image on the Internet.
5. Right-click webcam image.
6. Select properties for webcam image.
7. Highlight the address (URL) of the webcam image and copy to clip board.
8. Click the red pencil in the Source Picture field.  
The link external dialog box is displayed.
9. Add the URL for the webcam image.
10. Check the correctness of the entry: The webcam image is opened.
11. Click OK.
12. Modify Position and Scaling.
13. Click Apply to check the results of formatting in a preview.
14. If satisfied, click OK to finish.
15. Click OK to change to view.

## 5 Record consumption data

You can record consumption data for heating, hot water, chilled water, cooling electricity, natural gas or other media depending on the installed energy or volume meters. You can precisely track energy consumption by querying consumption data. Daily updated values, monthly values and for QAX9... annual due date values are available.

OZW772 as of V5.0

Energy and volume meters that use KNX data points are also supported as of integration of KNX S-Mode as of web server V5.0.

The meters can be connected directly or via KNX adapter to the KNX bus and transmit their data as per the configuration in ETS "Configuration in KNX S-Mode", see Section 9.1.

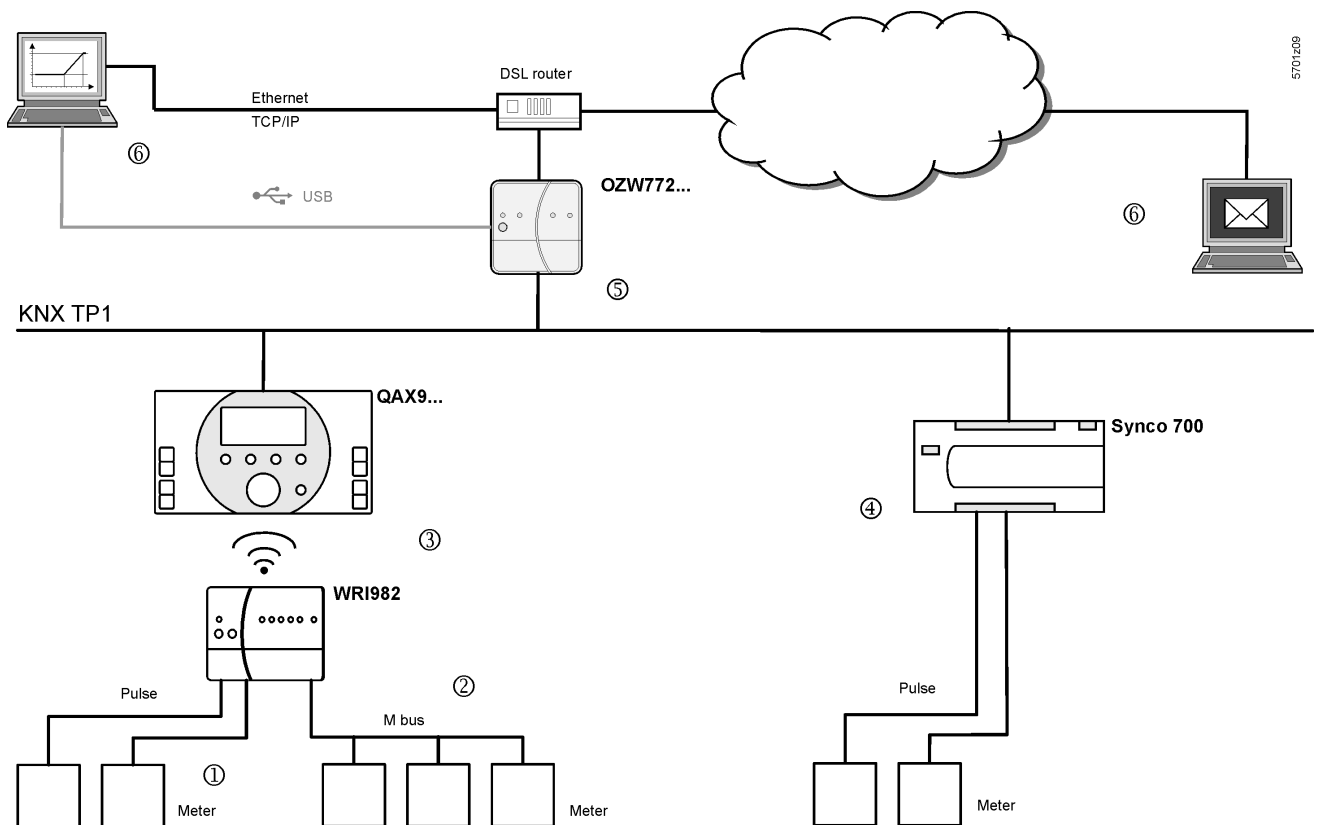

- ① The consumption data interface WRI982 continuously counts pending pulses.
- ② The WRI982 periodically queries consumption data on the M-bus meter.
- ③ The QAX9... periodically queries the consumption data interface WRI982.
- ④ The Synco 700 controller continuously counts pending pulses.
- ⑤ The OZW772... periodically queries consumption data.
- ⑥ You can view consumption data via web operation (local or remote) or have it send by e-mail.



- Compatible M-bus meters are listed in data sheet N2735 on the consumption data interface WRI982.
- The QAX9... documentation includes additional information on meter integration and consumption data acquisition up to QAX9...
- Information on pulse processing for Synco 700 controllers is available in the corresponding documentation on basic.
- Information on KNX S-Mode products is available in the manufacturer's product documentation.

## 5.1 Consumption data file

You can view the consumption data file via web operation (local or remote) (Section 3.4) or sent via e-mail (Section 5.3).

The consumption data file displays meters for those KNX devices with device pages generated on the web server.

Note



The device web pages must be re-generated after commissioning and changes to the plant (see Section 2.4).

Static metering information is available immediately after generation. The current values for operational meters are available in the consumption data file at the latest after 24 hours.

### 5.1.1 Main areas for consumption data file

my header						
<b>Plant information</b>						
<b>Plant name</b>	<b>Device address</b>	<b>Device type</b>	<b>Serial number</b>	<b>IP address</b>	<b>File created on</b>	
OZW772.04	0.2.150	OZW772.04	00FD00FEFF0C	192.168.251.1	10:29	04.01.2011
<b>Meter data</b>						
Device information				Meter information		
<b>Device name</b>	<b>Device address</b>	<b>Device type</b>	<b>Serial number</b>	<b>Meter name</b>	<b>Medium</b>	<b>Production r</b>
QAX913	0.2.200	QAX913-1	00FD0001889E	Electricity 1	Electricity	569
QAX913	0.2.200	QAX913-1	00FD0001889E	Heat/cooling energy 1	Heat (outlet)	569
QAX913	0.2.200	QAX913-1	00FD0001889E	Cold water 1	Cold water	5474166
QAX913	0.2.200	QAX913-1	00FD0001889E	Hot water 1	Hot water	5474167
Heizung	0.2.210	RMH760B-1	00FD00019940	meter 1		
<b>Meter replacement</b>						
Device information				Meter information		
<b>Device name</b>	<b>Device address</b>	<b>Device type</b>	<b>Serial number</b>	<b>Meter name</b>	<b>Medium</b>	<b>Production r</b>
my information line 1						
my information line 2						
my footer						

User defined texts

Header, Information line 1...10 and Footer are user defined settings that can be entered in the web operation for the web server (see Section 2.5.2).

Web server data

Plant information relies on the web server and is mapped "ad hoc" when querying and sending the consumption data file.

Meter data

Meter data is mapped in the web server based on information from Synco devices entered and generated under Device web pages.

## Meter exchange

The entire data set for the meter is moved when replacing a meter from the "Meter data" area to "Meter replacement".

In generation, the "Meter replacement" function ensures that last available values for any meter is retained even for billing purposes even after replacement.

## Notes



- The entire "Meter replace" area can be deleted (see Section 2.5.2).
- 2-year old data is deleted automatically.

## 5.1.2 Meter data in detail

1	A	B	C	D	E	F	G	H	I	J	K	L	M	N	O	P	Q	R	S	T			
1	my header																						
2																							
3	<b>Plant information</b>																						
4																							
5	<b>Plant name</b>	<b>Device addr.</b>	<b>Device type</b>	<b>Serial numbe</b>	<b>IP address</b>	<b>File created on</b>	<b>File version</b>																
6	OZW772.04	0.2.150	OZW772.04	00FD00FEFF0C	192.168.251.1	10.23	04.01.2011																
7																							
8	<b>Meter data</b>																						
9																							
10	<b>Device information</b>																						
11	<b>Device name</b>	<b>Device addr.</b>	<b>Device type</b>	<b>Serial numbe</b>	<b>Meter name</b>	<b>Medium</b>	<b>Production nu</b>	<b>Identification r</b>	<b>Unit</b>	<b>Current value</b>	<b>Time of day</b>	<b>Date</b>	<b>Operating ho</b>	<b>Meter state</b>	<b>Meter stat</b>	<b>Time of d. Date</b>	<b>Last due day</b>	<b>Value</b>	<b>Date</b>	<b>Last but one due day</b>	<b>Value</b>	<b>Date</b>	
12	QAX913	0.2.200	QAX913-1	00FD001889E	Electricity 1	Electricity	569	568	v/h	6543231	02.00	04.01.2011	924				6543231	31.12.2010	6543216	15.12.2010			
13	QAX913	0.2.200	QAX913-1	00FD001889E	Heat/cooling energy 1	Heat (outlet)	569	570	v/h	12369	02.00	04.01.2011	924				12369	31.12.2010	12353	15.12.2010			
14	QAX913	0.2.200	QAX913-1	00FD001889E	Cold water 1	Cold water	5474166	5474166	m3	0.2	23.53	03.01.2011	9508				0.2	31.12.2010	0.2	15.12.2010			
15	QAX913	0.2.200	QAX913-1	00FD001889E	Hot water 1	Hot water	5474167	5474167	m3	0.15	23.53	03.01.2011	9508				0.15	31.12.2010	0.15	15.12.2010			
16	Heizung	0.2.210	RM-H760B-1	00FD00019340	meter 1				k/vh	1257067	05.05	04.01.2011											
17																							
18	<b>Meter replacement</b>																						
19																							
20	<b>Device information</b>																						
21	<b>Device name</b>	<b>Device addr.</b>	<b>Device type</b>	<b>Serial numbe</b>	<b>Meter name</b>	<b>Medium</b>	<b>Production nu</b>	<b>Identification r</b>	<b>Unit</b>	<b>Current value</b>	<b>Time of day</b>	<b>Date</b>	<b>Operating ho</b>	<b>Meter state</b>	<b>Meter stat</b>	<b>Time of d. Date</b>	<b>Last due day</b>	<b>Value</b>	<b>Date</b>	<b>Last but one due day</b>	<b>Value</b>	<b>Date</b>	
22																							
23	my information line 1																						
24	my information line 2																						
25																							
26	my footer																						
--																							

U	V	W	X	Y	Z	AA	AB	AC	AD	AE	AF	AG	AH	AI	AJ	AK	AL	AM	AN	AO	AP	AQ	AR	AS	AT	AU
<b>Calendar monthly values</b>																			<b>Start value</b>							
<b>Value</b>	<b>Date</b>	<b>Value</b>	<b>Date</b>	<b>Value</b>	<b>Date</b>	<b>Value</b>	<b>Date</b>	<b>Value</b>	<b>Date</b>	<b>Value</b>	<b>Date</b>	<b>Value</b>	<b>Date</b>	<b>Value</b>	<b>Date</b>	<b>Value</b>	<b>Date</b>	<b>Value</b>	<b>Date</b>	<b>Value</b>	<b>Date</b>	<b>Value</b>	<b>Date</b>	<b>Value</b>	<b>Date</b>	
0	31.01.2010	0	28.02.2010	0	31.03.2010	0	30.04.2010	0	31.05.2010	0	30.06.2010	0	31.07.2010	0	31.08.2010	0.07	30.09.2010	0.18	31.10.2010	0.19	30.11.2010	0.2	31.12.2010	0.2	11.53	14.12.2010
0	31.01.2010	0	28.02.2010	0	31.03.2010	0	30.04.2010	0	31.05.2010	0	30.06.2010	0	31.07.2010	0	31.08.2010	0.06	30.09.2010	0.13	31.10.2010	0.14	30.11.2010	0.15	31.12.2010	0.15	15.53	14.12.2010

Value	Date	Value	Date	Value	Date	Value	Date	Value	Date	Value	Date	Value	Date	Value	Date	Value	Date	Value	Date	Value	Date	Value	Date	Value	Date		
6543210	30.11.2010	6543231	31.12.2010	6543216	10.00	14.12.2010	12353	10.00	14.12.2010	12369	10.00	14.12.2010	0.2	11.53	14.12.2010	0.15	15.53	14.12.2010	0.15	15.53	14.12.2010	0.15	15.53	14.12.2010	1257067	08.59	21.12.2010

**Key for data fields:**

A	Web server data (plant)	F1	Last due day
B	Device information (incl. meter name)	F2	Last but one due day
C	Meter information (excl. meter name)	G	Calendar monthly values
D	Current values	H	Start value web server
E	Meter state	T	Header
		U	Information lines
		V	Footer

## QAX / Synco 700 data

Data for device information, including meter name (data field B) are mapped to the web server based on information from the Synco devices immediately after generating.

## Note



Must be re-generated if settings are changed to integrated Synco devices.

## QAX / Synco 700 mapping

Meter information, not including meter name (data field C), current values (D), meter status (E), last due date (F1) and calendar monthly values (G) are collected at the QAX9... or on the Synco 700 controller (not E and not F1) and then retrieved by web server.

## Note



Data in the section on meter status (E) are specific to the manufacturer for M-bus meters.

Initialize QAX9...

The listed values are available for the first time on the QAX9...:

- For initial commissioning: After the connection test of WRI982 or automatically after 4 hours.
- For meter replacement: After two connection tests of WRI982 or automatically after 8 hours.

Web server constructs

- Web server copies data to "Last but one due date" (F2) from "Last due date" each time a **new** "Last due data" is read from QAX9....
- Web server maps the data in "Start value web server" (H) as soon as it receives the first measured value from each meter.

## 5.2 Time ratios

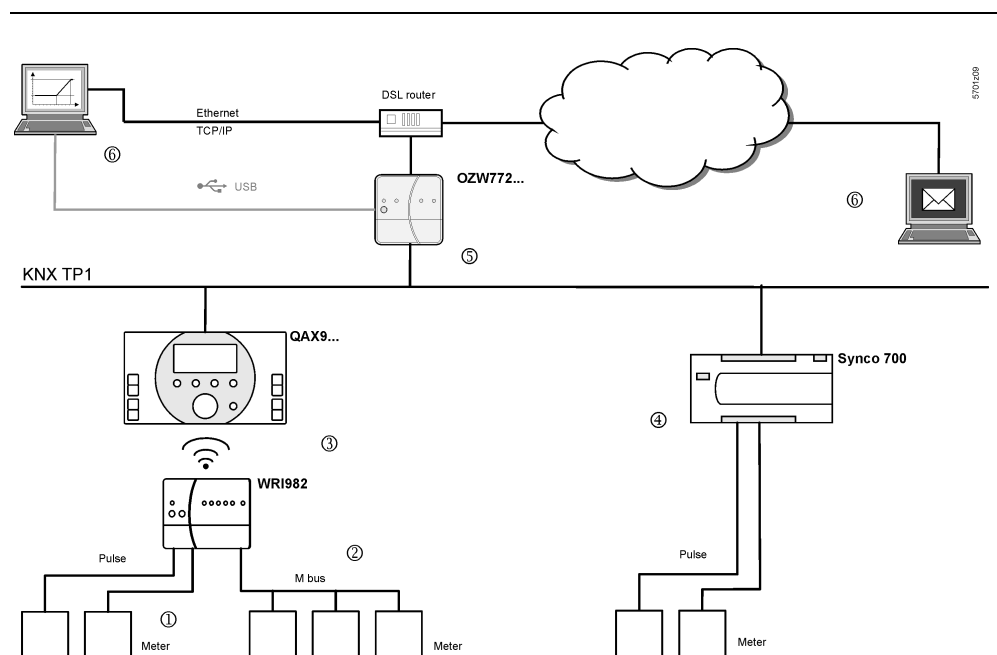

Current value

Meter → WRI982

- Consumption data from pulse meters is added up **once an hour** on WRI982.
- Consumption data from M-bus meters are read by WRI982 **every 4 hours**.

WRI982 → QAX9...

QAX9... reads the current values pending on WRI982 **every 4 hours**.

QAX9... → OZW772...

- Web server OZW772 reads the current consumption on the QAX9... **daily** between 5 and 10 am.
- Individual meter values are available immediately after reading.
- Reading is finished earlier accordingly on plants that do not fully use the maximum number of 512 meters.

Synco 700 → OZW772...

- The Synco 700 controller adds up the pulses every 5 minutes.
- Web server reads the current values **daily** between 5 and 10 am.
-



- S-Mode → OZW772...**
- The KNX S-Mode values are transmitted by meters with COV to the OZW772...
  - Current values, defined for a meter media, are taken over in the consumption data file **daily** between 5 and 10 am.
- OZW772... → Reading
- The user determines the read time for consumption data file via file transfer. With daily readings, the user can read the web server value up to 24 hours after the web server reading.
  - The consumption data file is sent by e-mail as soon as the consumption data is collected.
- Summary
- Via the chain (1) (3) (5) (6), the current values for WRI982 pulse meters are a maximum of 5 hours old plus read delay.
  - Via the chain (2) (3) (5) (6), the current values for M-bus meters are a maximum of 8 hours old plus read delay.
  - Via the chain (4) (5) (6), the current values for the pulse meters to Synco 700 controllers feature only the read delay.
- Current value time stamp
- The current value timestamp is written as follows to the consumption data file:
- For WRI982 pulse meters: Added up hourly by WRI982.
  - For M-bus meters **without** a manufacturer-specific timestamp: by QAX9..., at read time QAX9.../WRI982.
  - For M-bus meters with a manufacturer-specific timestamp: by the M-bus meter at the manufacturer-specific time.
  - For Synco 700 pulse inputs: By Synco 700 controller, added up every 5 minutes.

## Monthly values

- WRI982 → QAX9... Monthly values are transmitted every 24 hours.
- QAX9... → OZW772... The monthly values are transmitted on the third day of the month between 5 am and 10 pm.
- Note  Not all M-bus meters form their own monthly values. If not, the QAX9... assumes the task.
- Synco 700 → OZW772... The Synco 700 controller forms its own monthly value. The reading takes place on the third day of the month between 5 am and 10 pm.
- S-Mode → OZW772...** The OZW772... does not have an S-Mode input for monthly values and therefore does not provide any. The entry in the consumption data file remains blank.

## Due day

- Due day formation
- The due day values of meters connected to the QAX9... are formed on the centralized due day. The due day for QAX9... is active in the default state (Default setting of December 31), but can be edited on the QAX9... or via web server (see Section 2.5.2).
- Please note the following, however:
- A temporary due day value is formed during the commissioning of the QAX9...: This is the start value of the meter using the start value date.
  - The first due day value is formed using the due day date if the centralized due day is reached for the first time.

- Due days that differ from the centralized due day (by the corresponding M-bus meters) are blocked accordingly.
- A due day value is used for precision only if one M-bus meters supplies a due day value on the centralized due day.

#### Time ratios

WRI982 → QAX9... Due day values are transmitted every 4 hours.

QAX9... → OZW772... The due day values are transmitted on the third day of the month between 5 am and 10 pm.

Please note the following for the web server at the conclusion of the comments under "Due day formation":

- The temporary due day value and its dates is written to the due day field for in the consumption data file if the QAX9... has not yet achieved a due day by the first transmission to the web server.
- At the latest then, the first real due day value with due date is available on the QAX9... 12 months after commissioning and is written at the start of the next month (third day) to the field due day of the consumption data file.

#### Notes



- A due day value is still available on the web server on the third day of the month if the due day is set to the first day of a month.
- Synco 700 controllers do not support the due day function.
- The OZW772... do not have an S-Mode input for due date.

#### Replace meter

A change to the configuration of the QAX9.../ Synco 700 controller causes a meter replacement. The information is provided to the web server accordingly.

#### Notes



- A new generation of the device web pages after a device exchange of QAX9... or Synco 700 controller always results in a meter replacement even when the same meter is re-connected to the replacement device.
- Hiding a device in the device list also results in a meter replacement.

#### QAX9...

Changes to the following information are interpreted as a meter replacement:

- Meter medium
- Meter ID number

The following changes are also evaluated for pulse meters:

- Unit factor (e.g. from "10 Wh" to "100 Wh")
- Pulse value (counter or denominator)
- Start value

#### Synco 700 controller

Changes to the following information are interpreted as a meter replacement:

- Unit
- Format (number of decimal places)
- 

#### S-Mode meter

The following events are interpreted as meter changes:

- Change to data point type with ETS
- Change to meter media with ETS
- If the new value is less than the old value

## Time ratios

The following time ratios apply to meter replacement:

- It last up to 8 hours from the time the meter (as defined above) is replaced until the information is available on a consistent basis on the QAX9...
- The following midnight (12:00 am) OZW772... **automatically** re-generates all devices where it has detected a meter replacement.
- You must also wait 8 hours after meter replacement when generated manually.
- The following information is available immediately for Synco 700 controllers.
- After writing S-Mode data points with ETS, the device web page for OZW772... must be generated or updated.
- The OZW772... detects the meter replacement during the daily reading between 5 and 10 am.

## Web server start value

The web server maps the web server start value as soon as it receives the first meter value after generating the Synco device.

## Notes



- The web server start value is not the same as the start value for the meter available on the QAX9...
- An initial generation also occurs when the Synco device is hidden and then shown after using generate. The reason for the exception is that hiding Synco devices with meters is backed up using meter replacement. Otherwise, meters relevant to allocations can unintentionally disappear from the consumption data file.

## Exemption from liability

The Siemens system for transmitting acquired consumption data for meters uses the latest technology and security standards. The value as displayed on the meter applies for allocation purposes in the event of differences between the displayed value on the meter and the value as transmitted.

## 5.3 Send consumption data file

---

Settings are available under: Home > 0.2.150 OZW772.xx > Settings > Consumption data > Receiver > E-mail receiver 1...2

To set, see Section 2.5.2, consumption data/receiver.

Information on the e-mail outline is available in section 7.2.

Information on outline and content of the appended consumption data file is available in Section 5.1.

# 6 "Energy indicator" function

## 6.1 Introduction

### 6.1.1 Function description

#### "Energy indicator" function

The OZW772... web server from Version 4.0 supports the "Energy indicator" function.

The web server uses the "Energy indicator" function to read selected data point values from the bus devices and to compare the values to energy-related limit values, or so-called "Green limits".

The data points are also monitored for adherence to the "Green limits". As a result, the "Energy indicator" is displayed in the form of a tree leaf.

#### Monitored data points and their "Green limits"

The monitored data points and their "Green limits" depend on the device type. The following applies e.g. to a controller:

Monitored data points	"Green limits" (technical energy limit values)
Comfort heating setpoint	>22 °C
Economy heating setpoint	>16 °C
Comfort cooling setpoint	<23 °C
Economy cooling setpoint	<34 °C
Readjustment room unit	± 1.0 K ( ± readjustment has 2 "Green limits")
Preselection (operating modes)	Auto, Economy, Protection → "Green leaf" (continuous Comfort, Precomfort → "Orange leaf")

#### Notes

The "Green limits" are used only together with the "Energy indicator" function. They do **not** represent process or safety limit values which trigger e.g. fault messages or turn off the plant in the event of limit violations.

Users also are allowed to change data point values (setpoints). E-mail messages from the system then remind the user that a value or values were changed.

#### Tree leaf as "Energy indicator"

Green leaf 

"Green leaf" → Green tree leaf, leaf pointing up.

- The "Green leaf" symbol indicates that a data point value has not exceeded its "Green limit", i.e. the value is within a "green" range in terms of energy consumption.

Orange leaf 

"Orange leaf" → Orange tree leaf, leaf pointing down.

- The "Orange leaf" symbol indicates that a data point value has exceeded its "Green limit", i.e. the value is outside a "green" range in terms of energy consumption.

Grey leaf 

"Gray leaf" → Gray tree leaf, horizontal leaf.

- The "Grey leaf" symbol indicates that a data point value is not current, e.g. transmission of a data point value is incomplete, or there is no data communication with the bus.

No tree leaf

- The data point is not monitored via the "Energy indicator" function.

Standard EN 15232

The "Energy indicator" function is based on standard EN 15232 "Energy efficiency in buildings".

**Example: Web page  
"Energy indicator"**

Web page with "Energy indicator" function; example with data points from "Room 1" and open dialog box to set data point value "Comfort heating setpoint" and its "Green limit" (for "Room 1").

The screenshot shows the Siemens OZW772.250 web interface. The main content area displays a table of energy indicators for Room 1. An 'Edit' dialog box is open, allowing the user to adjust the 'Comfort heating setpoint' value to 21.0 and the 'Green limit(s)' to 22.0.

Energy indicator	Datapoint	Value	Green limit(s)
<input checked="" type="checkbox"/>	Preselection	Auto	Auto, Economy, Protection
<input checked="" type="checkbox"/>	Economy cooling setpoint	35.0 °C	34 °C
<input checked="" type="checkbox"/>	Precomfort cooling setpoint	28.0 °C	27 °C
<input checked="" type="checkbox"/>	Comfort cooling setpoint	24.0 °C	23 °C
<input checked="" type="checkbox"/>	Comfort heating setpoint	21.0 °C	22 °C
<input checked="" type="checkbox"/>	Precomfort heating setpoint	20.0 °C	21 °C
<input checked="" type="checkbox"/>	Economy heating setpoint	15.0 °C	16 °C
<input checked="" type="checkbox"/>	Readjustment room unit	0.0 K	1 K

**6.1.2 KNX bus topology**

The OZW772.01 web server can monitor 1 bus device via the "Energy indicator" function. The OZW772.04 web server can monitor up to 4, OZW772.16 up to 16, and OZW772.250 up to 250 bus devices via the "Energy indicator" function.

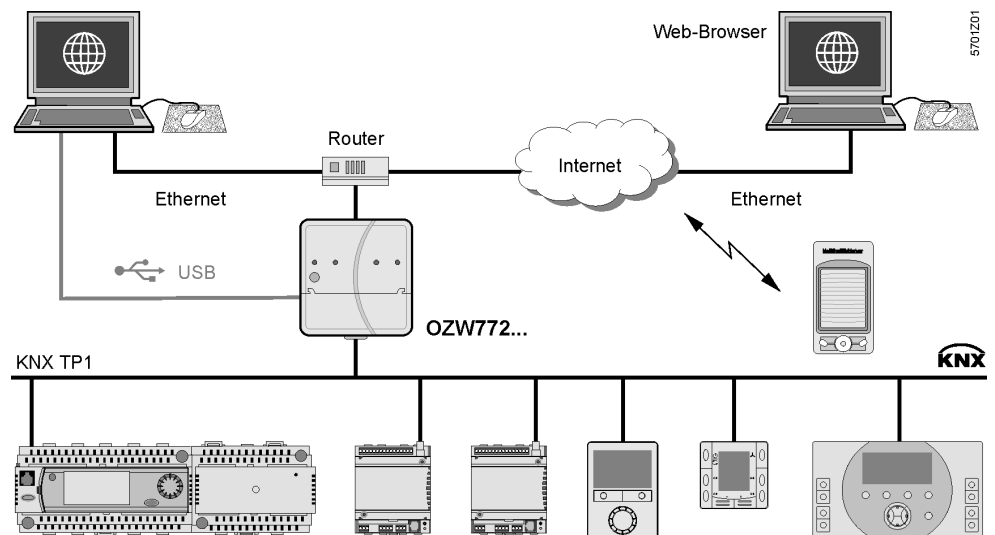

**Note**

A maximum processing time of ca. 8 hours results for a max. quantity of 2500 "Energy indicator" data points.

### 6.1.3 Synco product range

The following KNX devices from the Synco range can be connected to the OZW772... web server.

Synco range	Synco devices	Data sheet no.	
Synco 700	Universal controller	RMU7x0, RMU7x0B	N3144, N3150
	Heating controller	RMH760, RMH760B	N3131, N3133
	Boiler sequence controller	RMK770	N3132
	Central control unit	RMB795, RMB795B	N3121, N3122
	Switching & monitoring unit	RMS705, RMS705B	N3123, N3124
	Room unit	QAW740	N1633
Synco RXB/RXL	Room controller	RXB21.1, RXB22.1	N3873
	Room controller	RXL21.1, RXL22.1	N3877
	Room controller	RXB24.1	N3874
	Room controller	RXL24.1	N3878
	Room controller	RXB39.1/FC-13	N3875
	Room controller	RXL39.1/FC-13	N3876
Synco RDG/RDF/RDU	Room thermostat for fan coils	RDG100KN	N3191
	Room thermostat for VAV	RDG400KN	N3192
	Room thermostat for fan coils	RDF301	N3171
	Room thermostat for fan coils and lighting	RDF301.50	N3171
	Room thermostat for fan-coil	RDF600KN	N3171
	Touchscreen thermostat for fan-coil	RDF800KN	N3174
Synco living	Room thermostat for VAV	RDU341	N3172
	Central apartment unit	QAX903	N2741
	Central apartment unit	QAX910	N2707
Central apartment unit	QAX913	N2740	

**Important note** The "Energy indicator" function is supported in all Synco devices (see table above) excepting:  
 Synco 700: RMU7x0, RMH760, RMK770 V1, RMS705  
 Synco living: QAX910 V1 und V2

**Device description** If the "Device description" of a device contains "Energy indicator" data points and "Green limits", the device can be operated on the "Energy indicator" function. "Energy indicator" data points and "Green limits" have predefined, device-specific default values. The default values can be changed with a few notable exceptions. Neither number nor selection of the "Energy indicator" data points and "Green limits" that exist in the "Device description" can be changed.

## 6.1.4 Navigation and device web pages

### Navigation

Go to the "Energy indicator" function as follows:

- Via primary navigation, main function "Energy indicator".
- Click the "Plant state Energy indicator" pane (top right field pane tree leaf in the screenshot below).

### Primary navigation

On the web page, you can select the "Energy indicator" function from the primary navigation next to "Home".

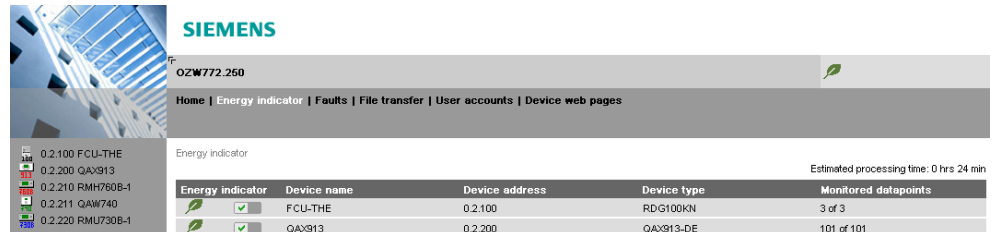

The screenshot shows the Siemens web interface for plant OZW772.250. The primary navigation bar includes 'Home', 'Energy indicator', 'Faults', 'File transfer', 'User accounts', and 'Device web pages'. The 'Energy indicator' function is selected. Below the navigation bar, there is a table of devices:

Energy indicator	Device name	Device address	Device type	Monitored datapoints
	FCU-THE	0.2.100	RD-G100KN	3 of 3
	QA-X913	0.2.200	QA-X913-DE	101 of 101

### Secondary navigation

In secondary navigation, both partial plants and/or devices are displayed sorted by device address in ascending order.

### Device web pages status "Generated"

Status "Generated" in column "Status" in "Device web pages" is a precondition for displaying the devices using the "Energy indicator" function (see Section 2.4).

Path: Home > ... > Device web pages

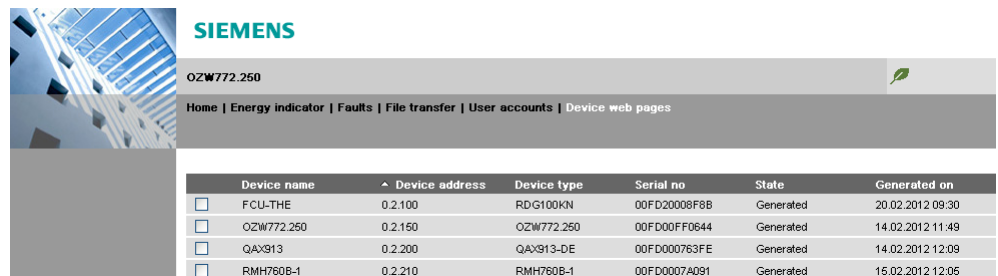

The screenshot shows the Siemens web interface for plant OZW772.250. The secondary navigation bar includes 'Home', 'Energy indicator', 'Faults', 'File transfer', 'User accounts', and 'Device web pages'. The 'Device web pages' pane is selected. Below the navigation bar, there is a table of devices:

Device name	Device address	Device type	Serial no	State	Generated on
<input type="checkbox"/> FCU-THE	0.2.100	RD-G100KN	00FD20008F8B	Generated	20.02.2012 09:30
<input type="checkbox"/> OZW772.250	0.2.150	OZW772.250	00FD00FF0644	Generated	14.02.2012 11:49
<input type="checkbox"/> QA-X913	0.2.200	QA-X913-DE	00FD000763FE	Generated	14.02.2012 12:09
<input type="checkbox"/> RMH760B-1	0.2.210	RMH760B-1	00FD0007A091	Generated	15.02.2012 12:05

### Note

The "Device web pages" (see screenshot) pane can be opened with "Service" and "Administrator" access rights.

## 6.2 "Energy indicator" function levels

### Level designations

The contents of the "Energy indicator" function are distributed across 2 or 3 levels depending on the functionality of the respective device.

- Simple devices have 2 levels:
  - "Plant"
  - "Data points"
- Complex devices have 3 levels:
  - "Plant"
  - "Partial plants"
  - "Data points"

### 6.2.1 "Plant" level

#### Enter the "Plant" level

Enter the "Plant" level as follows:

- Click the "Energy indicator" function (primary navigation) or
- Click the "Plant state Energy indicator" pane.

The "Plant" level shows all devices of a plant subject to the "Energy indicator" function.

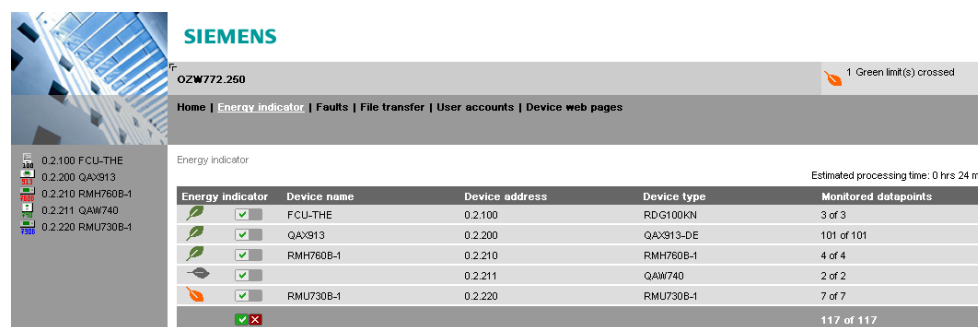

The screenshot shows the Siemens Energy indicator web interface. The top navigation bar includes "Home | Energy indicator | Faults | File transfer | User accounts | Device web pages". The main content area displays a table of devices with columns for "Energy indicator", "Device name", "Device address", "Device type", and "Monitored datapoints". A summary row at the bottom shows "117 of 117" monitored datapoints.

Energy indicator	Device name	Device address	Device type	Monitored datapoints
	FCU-THE	0.2.100	RD-G100KN	3 of 3
	QA913	0.2.200	QA913-DE	101 of 101
	RMH760B-1	0.2.210	RMH760B-1	4 of 4
	QAW740	0.2.211	QAW740	2 of 2
	RMU730B-1	0.2.220	RMU730B-1	7 of 7
				117 of 117

"Energy indicator" for a plant

The "Energy indicator" of the plant is displayed as a **summary display** in the "Plant state Energy indicator" pane. See Section 6.2.6 for information on the summary display.

"Energy indicator" for devices

The "Energy indicator" for devices is displayed at the "Plant" level in the "Energy indicator" column for each device.

Next lower level

Clicking the name of a device in secondary navigation or in the "Device name" column opens the next lower level for that device.

#### Table columns

Energy indicator

"Energy indicator" (tree leaf) for each actively monitored device.

This column also contains:

- Checkboxes to activate/deactivate monitoring of the "Energy indicator" data points for the selected device.
- Summary checkbox (green/red) to activate/deactivate monitoring for all data points of the plant.  
The summary checkbox is available only for access level "Administrator"; see Section 6.3.4.  
When a checkbox is cleared (deactivated), message "Monitoring off, green limits reset to default values! Really to be continued?" is displayed; see Section 6.3.4.



Device name, device type	The device name is displayed if defined (prior to creating the "Device list"), otherwise the device type.  The devices are sorted by device address in ascending order.
Device address	Network address (area.line.device address)
Device type	Device type (technical device designation)
Monitored data points	Indication of the number of <b>actively</b> monitored data points (x) for possible number of data points to be monitored (y) for each device; see Section 6.2.4.
Note	Clicking the column title <ul style="list-style-type: none"> <li>• Device name</li> <li>• Device address</li> <li>• Device type</li> </ul> sorts the column contents in the table in ascending or descending order.

## 6.2.2 "Partial plants" level

### "Partial plants" level

The "Partial plants" level shows the partial plants of functionally complex devices (see partial plants below for QAX913 central apartment unit).

Energy indicator	Partial plant name	Monitored datapoints
	Apartment operating mode	1 of 1
	Room 1	8 of 8
	Room 2	8 of 8
	Room 3	8 of 8
	Room 4	8 of 8
	Room 5	8 of 8
	Room 6	8 of 8
	Room 7	8 of 8
	Room 8	8 of 8
	Room 9	8 of 8
	Room 10	8 of 8
	Room 11	8 of 8
	Room 12	8 of 8
	DHW	4 of 4

Next lower level	Clicking the name of a partial plant in secondary navigation or in the "Partial plant name" column opens the next lower level for that partial plant.
Next higher level	Clicking  (in secondary navigation) opens the next higher level.
<b>Table columns</b>	
Energy indicator	"Energy indicator" (tree leaf) for each actively monitored partial plant. This column also contains the checkboxes to activate/deactivate "Energy indicator" monitoring of the data points for the selected partial plant (deactivate without confirmation message).
Partial plant name	Name of the partial plant (taken over by device).
Monitored data points	Indication of the number of <b>actively</b> monitored data points (x) for possible number of data points to be monitored (y) for each partial plant; see Section 6.2.4.

Notes

When level "Partial plants" is selected, they are sorted by "Device description". Users cannot change the sort order.

In functionally complex devices with many data points, they are assigned to the partial plants. The data points of the partial plants (per partial plant) are displayed at the "Data point" level; see below.

The "Partial plants" level is not available in functionally simple devices with few data points.

### 6.2.3 "Data points" level

#### "Data points" level

The "Data points" level shows the data points to be monitored (see the data points for partial plant "Room 1" below).

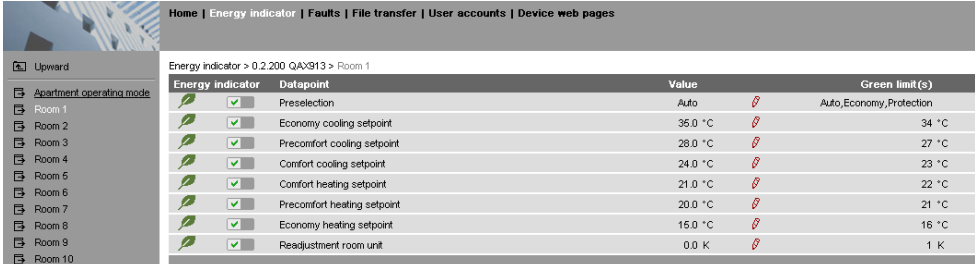

The screenshot shows a web interface with a navigation menu on the left and a main content area. The main content area displays a table of data points for 'Room 1'. The table has columns for 'Energy indicator', 'Datapoint', 'Value', and 'Green limit(s)'. The 'Energy indicator' column contains tree leaf icons and checkboxes. The 'Value' column contains numerical values with units. The 'Green limit(s)' column contains text values.

Energy indicator	Datapoint	Value	Green limit(s)
<input checked="" type="checkbox"/>	Preselection	Auto	Auto, Economy, Protection
<input checked="" type="checkbox"/>	Economy cooling setpoint	35.0 °C	34 °C
<input checked="" type="checkbox"/>	Precomfort cooling setpoint	28.0 °C	27 °C
<input checked="" type="checkbox"/>	Comfort cooling setpoint	24.0 °C	23 °C
<input checked="" type="checkbox"/>	Comfort heating setpoint	21.0 °C	22 °C
<input checked="" type="checkbox"/>	Precomfort heating setpoint	20.0 °C	21 °C
<input checked="" type="checkbox"/>	Economy heating setpoint	15.0 °C	16 °C
<input checked="" type="checkbox"/>	Readjustment room unit	0.0 K	1 K

Next higher level

Clicking (in secondary navigation) opens the next higher level.

#### Table columns

Energy indicator

"Energy indicator" (tree leaf) for each actively monitored data point.

This column also contains the checkboxes to activate/deactivate "Energy indicator" monitoring of the selected data point (deactivate without confirmation message).

Data point

Name of the data point.

Value

Value of the data point (dependent on data point type with unit, e.g. °C).

Symbol (red pen)

Clicking the red pen symbol opens the dialog box for the selected data point; see Section 6.4.

Green limit(s)

Value of the set "Green limit" (dependent on data point type and unit).

Enumeration values for "Green leaf" are displayed for "Green limits" with enumeration values such as Auto, Comfort, Economy.

Invisible values are replaced by dots "..." if not all enumeration values can be displayed. The dialog box (click red pen symbol ) shows all enumeration values.

Note

When level "Data points" is selected, they are sorted by "Device Description". Users cannot change the sort order.







## 6.2.4 Number of "Monitored data points"

### Column "Monitored data points"

The "Monitored data points" column shows the number of **actively** monitored data points (x) compared to the number of data points (y) that could be monitored.













"Plant" level

"x of y" is displayed for each device and partial plant in the corresponding row. The sum of all devices and partial plants is displayed in the bottom row.

Energy indicator	Device name	Device address	Device type	Monitored datapoints
 <input checked="" type="checkbox"/>	FCU-THE	0.2.100	RDG100KN	2 of 3
 <input checked="" type="checkbox"/>	QAX913	0.2.200	QAX913-DE	93 of 101
 <input checked="" type="checkbox"/>	RMH760B-1	0.2.210	RMH760B-1	4 of 4
 <input checked="" type="checkbox"/>		0.2.211	QAW740	1 of 2
 <input checked="" type="checkbox"/>	RMU730B-1	0.2.220	RMU730B-1	7 of 7
 <input checked="" type="checkbox"/>				<b>107 of 117</b>

"Partial plants" level

"x of y" is displayed for each partial plant in the corresponding row and the sum of all partial plants is displayed in the bottom row.

Energy indicator	Partial plant name	Monitored datapoints
 <input checked="" type="checkbox"/>	Apartment operating mode	1 of 1
 <input checked="" type="checkbox"/>	Room 1	8 of 8
 <input checked="" type="checkbox"/>	<b>Room 2</b>	<b>0 of 8</b>
 <input checked="" type="checkbox"/>	Room 3	8 of 8
 <input checked="" type="checkbox"/>	Room 4	8 of 8
 <input checked="" type="checkbox"/>	Room 5	8 of 8
 <input checked="" type="checkbox"/>	Room 6	8 of 8
 <input checked="" type="checkbox"/>	Room 7	8 of 8
 <input checked="" type="checkbox"/>	Room 8	8 of 8
 <input checked="" type="checkbox"/>	Room 9	8 of 8
 <input checked="" type="checkbox"/>	Room 10	8 of 8
 <input checked="" type="checkbox"/>	Room 11	8 of 8
 <input checked="" type="checkbox"/>	Room 12	8 of 8
 <input checked="" type="checkbox"/>	DHW	4 of 4
		<b>93 of 101</b>

Note

Level "Data points" does not have indication "x of y".

## 6.2.5 "Energy indicator" visibility

### Configuration of visibility

Visibility of the "Energy indicator" symbol is configured at the "Administrator" access level and "Service" in the web server.

Path: OZW772.xx > Settings > Energy indicator > Energy indicator on the web (very bottom of web page)

The screenshot shows the configuration page for the 'Energy indicator' in a web server. The page has a breadcrumb trail: Home > Energy indicator | Faults | File transfer | User accounts | Device web pages. A left sidebar contains a tree view with items like 'Web server', 'Time of day/date', 'Communication', 'Message receiver', 'System report', 'Consumption data', 'Energy indicator', 'Faults', and 'Texts'. The main content area is a table with columns 'Datapoint' and 'Value'. The table lists various settings for two email receivers. An 'Edit' dialog box is open over the 'Energy indicator on the web' row, showing two radio buttons: 'Not visible' (unselected) and 'Visible' (selected). The dialog has 'OK' and 'Cancel' buttons. The table row for 'Energy indicator on the web' shows the value 'Visible'.

Datapoint	Value
E-mail receiver 1	
E-mail address	mailrecipient@example.com
Transmit time 1	00:00 h:m
Release transmit time 1	Off
Transmit time 2	00:00 h:m
Release transmit time 2	Off
Test receiver	—
Energy indicator sent	—
Cause	—
E-mail receiver 2	
E-mail address	mailrecipient@example.com
Transmit time 1	00:00 h:m
Release transmit time 1	Off
Transmit time 2	00:00 h:m
Release transmit time 2	Off
Test receiver	—
Energy indicator sent	—
Cause	—
Visibility	—
Energy indicator on the web	Visible

### Notes

"Energy indicator" remains active even if "Energy indicator on the web = Not visible" is selected.

Configuration "Energy indicator on the web" (Visible/Not visible) also applies to user groups "Service" and "End user".

## 6.2.6 Summary display "Energy indicator" for a plant

### Summary display

The "Energy indicator" of the plant OR-links the "Energy indicators" of all devices across all levels. It is displayed as a summary:

- LED ① on the web server (see figure in Section 1.2).
- Web page "Plant" in the "Plant state Energy indicator" pane.

### LED ① on web server

The following colors of LED ① on the web server front mean:

- LED is lit green "Energy indicator" of the plant = "Green leaf".
- LED is lit orange "Energy indicator" of the plant = "Orange leaf".

### Summary display "Plant" web page

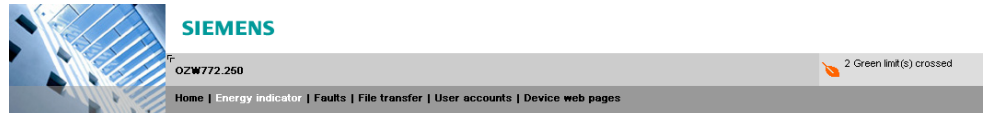

- "Green leaf"  
All actively monitored data points of the plant are within limits, i.e. no "Green limits" are violated.
- "Orange leaf"  
At least one monitored data point is outside its "Green limit".  
The number of data points outside their "Green limit" is displayed in addition to the tree leaf.

The summary display "Orange leaf" with "2 Green limit(s) crossed" is displayed (in the previous example) because two "Green limits" were exceeded in "Controller 1" (see next screenshot).

Energy indicator	Datapoint	Value	Green limit(s)
	<input checked="" type="checkbox"/> Economy cooling setpoint	33.9 °C	34 °C
	<input checked="" type="checkbox"/> Precomfort cooling setpoint	28.0 °C	27 °C
	<input checked="" type="checkbox"/> Comfort cooling setpoint	24.0 °C	23 °C
	<input checked="" type="checkbox"/> Comfort heating setpoint	21.0 °C	22 °C
	<input checked="" type="checkbox"/> Precomfort heating setpoint	19.0 °C	21 °C
	<input checked="" type="checkbox"/> Economy heating setpoint	16.1 °C	16 °C

## 6.3 "Energy indicator" commissioning function

### 6.3.1 Commissioning notes

#### Prerequisites

Prerequisites for commissioning the "Energy indicator" function:

- Login with "Administrator" access right.
- Generating the devices in the web server. This generates the "Energy indicator" data points for each device.
- Devices on the Device web pages must have status "Generated".

#### Device web pages

Home | Energy indicator | Faults | File transfer | User accounts | Device web pages

Device name	Device address	Device type	Serial no	State	Generated on
<input type="checkbox"/> OZW772.250	0.2.150	OZW772.250	00FD00FF0644	Generated	23.02.2012 10:59
<input type="checkbox"/> QAX913	0.2.200	QAX913-DE	00FD000763FE	Generated	23.02.2012 11:56
<input type="checkbox"/> RMH760B-1	0.2.210	RMH760B-1	00FD0007A091	Generated	23.02.2012 12:00
<input type="checkbox"/>	0.2.211	QAW740	00FD00076B24	Generated	23.02.2012 12:04
<input type="checkbox"/> RMU730B-1	0.2.220	RMU730B-1	00FD0007980B	Generated	23.02.2012 12:08
<input type="checkbox"/> Device 230	0.2.230	RMU730-1	00FD00001DF7	Generated	23.02.2012 12:09

Add Delete Generate Hide

### 6.3.2 Start "Energy indicator" function

#### Start "Energy indicator" function

The "Energy indicator" function in the OZW772... web server is started automatically if the above prerequisites are fulfilled.

#### Notes

The devices must contain at least one "Energy indicator" data point to be displayed as part of the "Energy indicator" function.

The "Energy indicator" database only exists on the web server. And the web server itself has no data points subject to the "Energy indicator" function.

#### Temporary status

"---" is temporarily displayed for a data point's status in the "Value" column until the data point value is read and processed via the bus.

Energy indicator	Datapoint	Value	Green limit(s)
	<input checked="" type="checkbox"/> Preselection	Auto	Auto, Economy, Protection
	<input checked="" type="checkbox"/> Economy cooling setpoint	34.0 °C	34 °C
	<input checked="" type="checkbox"/> Precomfort cooling setpoint	28.0 °C	27 °C
	Comfort cooling setpoint	---	---
	Comfort heating setpoint	---	---
	Precomfort heating setpoint	---	---
	Economy heating setpoint	---	---
	Readjustment room unit	---	---

#### Updates on the web page

A maximum of 4 "Energy indicators" per second are updated on a web page. The actual number depends on effective bus load. In the event of concurrent user access, bandwidth is distributed across all users.

#### Note

Device data point values are not transmitted if there is no bus supply or if the KNX bus is interrupted.

No comparison to "Green limits" then takes place and column "Value" contains "---" while column "Energy indicator" displays a "Grey leaf".

### 6.3.3 Estimated processing time







After starting the "Energy indicator" function, the "Plant" web page contains the following:

- Summary display "Energy indicator"; see Section 6.2.6.
- Number of monitored data points; see Section 6.2.4.
- "Estimated processing time"; see below.

#### Estimated processing time

The "Estimated processing time" is displayed in hours and minutes.

Energy indicator Estimated processing time: 0 hrs 24 min

Energy indicator	Device name	Device address	Device type	Monitored datapoints
 <input checked="" type="checkbox"/>	FCU-THE	0.2.100	RDG100KN	3 of 3
 <input checked="" type="checkbox"/>	QAX913	0.2.200	QAX913-DE	101 of 101
 <input checked="" type="checkbox"/>	RMH760B-1	0.2.210	RMH760B-1	4 of 4
 <input checked="" type="checkbox"/>		0.2.211	QAW740	1 of 2
 <input checked="" type="checkbox"/>	RMU730B-1	0.2.220	RMU730B-1	7 of 7
				116 of 117

#### Processing time at base load

When monitoring is active, the web server first reads each data point from the bus devices and then compares the values to its "Green limit".

Processing time at base load per data point is 12 seconds (longer if the bus carries a heavy load).

#### Updated display for "Energy indicator"

The web server can process up to 2500 "Energy indicator" data points. Thus, updating the "Energy indicator" (leaf color) display may take hours. Therefore:

- "Green leaf" (start-up mode)  
The "Green leaf" display does not necessarily reflect the current plant state prior to completion of the "Estimated processing time".
- The updated display of "Energy indicator" can be postponed by max. the "Estimated processing time".

#### Note

Note the restriction from the "updated "Energy indicator" display" also when navigating to other web pages.

### 6.3.4 Deactivating "Data point monitoring"

#### Deactivation

Monitoring "Energy indicator" data points is activated automatically following device list creation.

Thus, data point monitoring can only be deactivated as a first step.

- Deactivation for "Data point monitoring" requires "Administrator" access rights.

The checkbox in the "Energy indicator" column allows for deactivating monitoring of one or multiple data points e.g. for operational reasons.



- Data point monitoring active (default following commissioning)
- Data point monitoring deactivated

"Plant" level  
 Selecting the checkbox deactivates the data points for the selected device (can be reactivated).  
 Selecting the summary checkbox (green/red, bottom row) deactivates the data points for the plant (can be reactivated)).

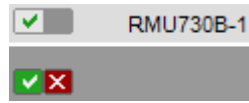

Note  
 A **confirmation message** is displayed when data point monitoring for a device or plant is deactivated; see below.

"Partial plants" level  
 Selecting the checkbox deactivates the data points for the selected partial plant (can be reactivated)).  
**No confirmation message** is displayed when data point monitoring for a partial plant is deactivated.

"Data points" level  
 Selecting the checkbox deactivates the selected data point (can be reactivated)).  
**No confirmation message** is displayed prior to deactivating monitoring.

**Confirmation message for "Monitoring off"**  
 A confirmation message is displayed when data point monitoring for a device or plant is deactivated:

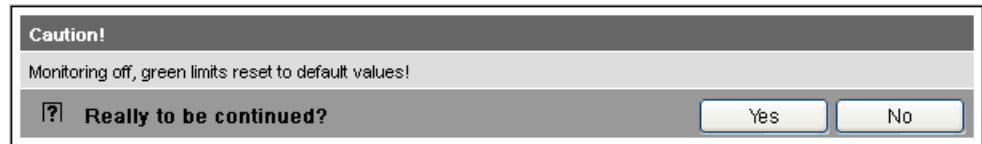

Green limits to default values!  
 Clicking [ Yes ] for message "Really to be continued?" to deactivate monitoring also resets "Green limits" (changed by the user) to their default values. Therefore: "Monitoring off" deactivates monitoring while, at the same time, setting the "Green limits" to the default values of device list creation.

Note  
 Contrary to the "Green limits", deactivation does **not** reset changed data point values to default values. Therefore:  
 Following "Monitoring off" and reactivation, "Energy indicator" data points may no longer be within the green limits, as the "Green limits" reset to default values have different dependencies.



### 6.3.5 Activating "Data point monitoring"

#### Activation

Monitoring "Energy indicator" data points is activated automatically following device list creation.

Data point monitoring can thus be activated only following deactivation; see Section 6.3.4.

- Activation for "Data point monitoring" requires "Administrator" access rights.

The checkbox in the "Energy indicator" column allows for activating monitoring of one or multiple data points e.g. following temporary deactivation.

- Data point monitoring deactivated (by user)
- Data point monitoring activated

#### "Plant" level

Selecting the checkbox activates the data points for the selected device.

Selecting the summary checkbox (green/red, bottom row) activates the data points for the plant.



#### "Partial plants" level

Selecting the checkbox activates the data points for the selected partial plant.

#### Example

Monitoring is deactivated for partial plant "Room 2". As a result, all data points are deactivated.

Partial plant "Room 2" is deactivated.

Energy indicator	Partial plant name
 <input checked="" type="checkbox"/>	Apartment operating mode
 <input checked="" type="checkbox"/>	Room 1
<input type="checkbox"/>	Room 2

"Monitored data points" 0 of 8.

Monitored datapoints
1 of 1
8 of 8
<b>0 of 8</b>



ftg

Selecting the checkbox for partial plant "Room 2" activates it. As a result, all data points at the "Data points" level are also activated.









Data points "Room 2" are deactivated.

Energy indicator	Datapoint
<input type="checkbox"/>	Preselection
<input type="checkbox"/>	Economy cooling setpoint
<input type="checkbox"/>	Precomfort cooling setpoint
<input type="checkbox"/>	Comfort cooling setpoint
<input type="checkbox"/>	Comfort heating setpoint
<input type="checkbox"/>	Precomfort heating setpoint
<input type="checkbox"/>	Economy heating setpoint
<input type="checkbox"/>	Readjustment room unit

Partial plant "Room 2" is reactivated.

Energy indicator	Partial plant name
 <input checked="" type="checkbox"/>	Apartment operating mode
 <input checked="" type="checkbox"/>	Room 1
 <input checked="" type="checkbox"/>	Room 2

All data points of "Room 2" are reactivated.

Energy indicator	Datapoint
 <input checked="" type="checkbox"/>	Preselection
 <input checked="" type="checkbox"/>	Economy cooling setpoint
 <input checked="" type="checkbox"/>	Precomfort cooling setpoint
 <input checked="" type="checkbox"/>	Comfort cooling setpoint
 <input checked="" type="checkbox"/>	Comfort heating setpoint
 <input checked="" type="checkbox"/>	Precomfort heating setpoint
 <input checked="" type="checkbox"/>	Economy heating setpoint
 <input checked="" type="checkbox"/>	Readjustment room unit

"Data points" level

Selecting the checkbox activates the selected data point.

Example

Starting point: All data points of partial plant "Room 2" are deactivated.  
Activating just one data point (of partial plant "Room 2") also activates the partial plant.

A data point of partial plant "Room 2" is activated.

Energy indicator	Datapoint
<input type="checkbox"/>	Preselection
<input type="checkbox"/>	Economy cooling setpoint
<input checked="" type="checkbox"/>	<b>Precomfort cooling setpoint</b>
<input type="checkbox"/>	Comfort cooling setpoint
<input type="checkbox"/>	Comfort heating setpoint
<input type="checkbox"/>	Precomfort heating setpoint
<input type="checkbox"/>	Economy heating setpoint
<input type="checkbox"/>	Readjustment room unit

Partial plant "Room 2" is automatically activated.

Energy indicator	Partial plant name
<input checked="" type="checkbox"/>	Apartment operating mode
<input checked="" type="checkbox"/>	Room 1
<input checked="" type="checkbox"/>	<b>Room 2</b>
<input checked="" type="checkbox"/>	Room 3
<input checked="" type="checkbox"/>	Room 4
<input checked="" type="checkbox"/>	Room 5
<input checked="" type="checkbox"/>	Room 6
<input checked="" type="checkbox"/>	Room 7

Note

Note that "Monitoring activated" at the "Partial plants" level does not mean that **all** subordinate data points are activated and monitored also. This also applies to "Monitoring activated" at the "Plant level".

## 6.4 Dialog boxes, data points, and "Green limits"

### 6.4.1 General dialog boxes

#### Open a dialog box

Clicking the red pen  symbol opens the dialog box for the selected data point. This allows you to either change the data point value and/or the "Green limit".

Example: Dialog box  
Comfort heating setpoint

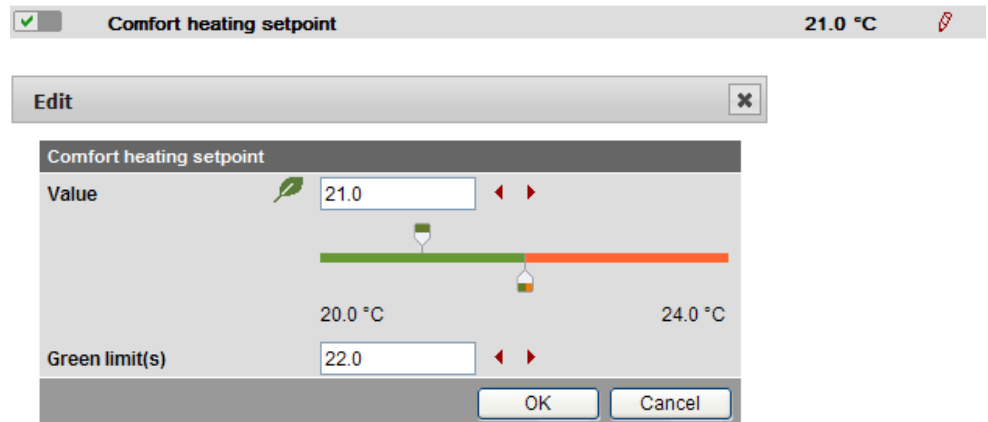

#### Contents



The dialog box contains the following information (example: Comfort heating setpoint):

- Name (data point) Comfort heating setpoint
- Value (data point) 21.0
- "Energy indicator" as:
  - "Green leaf" Green tree leaf
  - "Orange leaf" Orange tree leaf
- "Green limit(s)" 22.0
- Setting range 20.0 °C to 24.0 °C for data point and "Green limit(s)"

#### Value

Data point value

The set data point value is displayed in the field above the setting range. There are 3 ways to change the data point value:

- Change the data point value in the entry field.
- Move the data point slider to the right or left.
- Arrows   to adjust the value step by step.

The data point slider is green for as long as the data point value is within the green setting range (up to and including "Green limit"). If the data point value is moved to the orange range, the slider turns orange.



#### Setting range

Bars

The setting range for the data point value and its "Green limit" corresponds to the green/orange bar limited by value indications to the right and left of the bar.

#### Green limit(s)

Each data point monitored with the "Energy indicator" function has its own "Green limit". There are 3 ways to change the "Green limit":

- Change the value for the "Green limit(s)" in the entry field.
- Move the "Green limit(s)" slider to the right or left.
- Arrows   to adjust the value step by step.

The "Green limit" slider is always "green/orange". If the slider is moved to the setting range limit value, the bar color disappears in the direction of the movement.

Notes

The default values defined for data point and "Green limit(s)" in the "Device description" are displayed in the corresponding entry field.

After values are changed (by the user), default values can be regenerated only by deactivating "Data point monitoring" (with summary checkbox).

## 6.4.2 Dialog boxes with numeric data points

In numeric data points such as Comfort heating setpoint and Comfort cooling setpoint, the "Green limits" may depend on neighboring values. Therefore:

To achieve the desired setting range, the data points (heating and cooling setpoints) and their "Green limits" must be set in relation to the neighboring value.

Note

Dependency of neighboring values always depends on the data point values (setpoints), not the "Green limits".

### Comfort heating setpoint

Comfort heating setpoint

Value  21.0

19.0 °C 24.0 °C

Green limit(s) 22.0

OK Cancel

Note

Set the heating setpoint by 1 K lower (or max. the same) as the "Green limit" to display the "Energy indicator" = "Green leaf".

### Comfort cooling setpoint

Comfort cooling setpoint

Value  24.0

21.0 °C 28.0 °C

Green limit(s) 23.0

OK Cancel

Note

Set the cooling setpoint by 1 K higher (or max. the same) as the "Green limit" to display the "Energy indicator" = "Green leaf".

**Readjustment room unit**

In the "Readjustment room unit" dialog box, the adjustable data point value corresponds to the adjustment range, symmetrical to the zero-point axis. This requires 2 "Green limits".

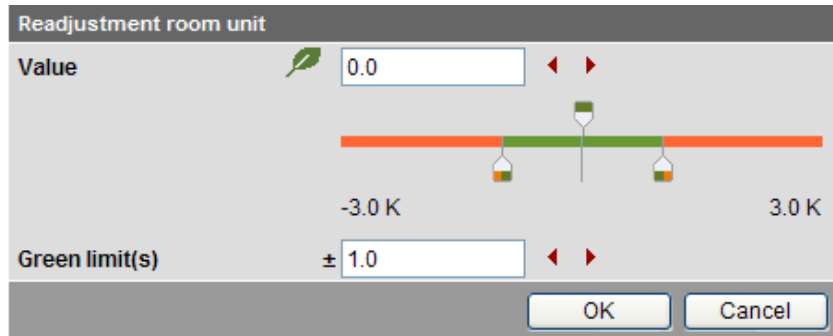

**6.4.3 Dialog boxes with enumeration data points**

A dialog box with enumeration values, at least one "Green limit" for a value to be monitored needs to be set.

**Preselection operating mode**

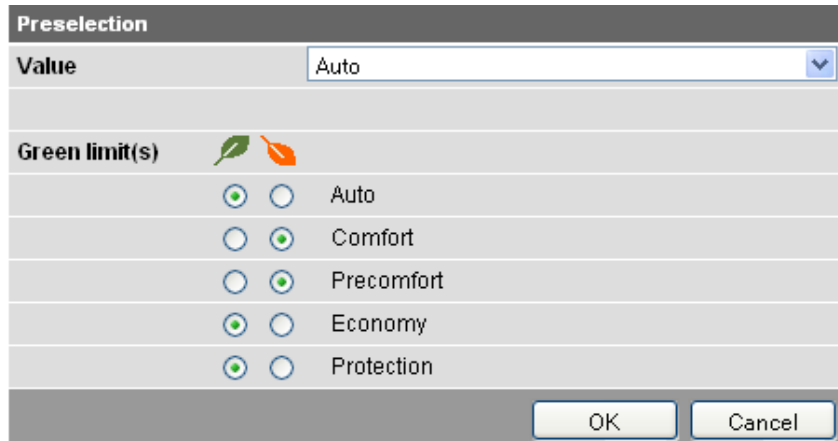

**Note**

The enumeration values are predefined as per the data point type. The "Green limit(s)" are set by clicking the selection boxes.

## 6.4.4 Dialog boxes with variable unit data points

Synco 700 universal devices can be used either to control temperature, humidity, or other physical variables. The setpoint is thus set with the corresponding variable, e.g. in [°C], [% r.h.] or [Pa] .

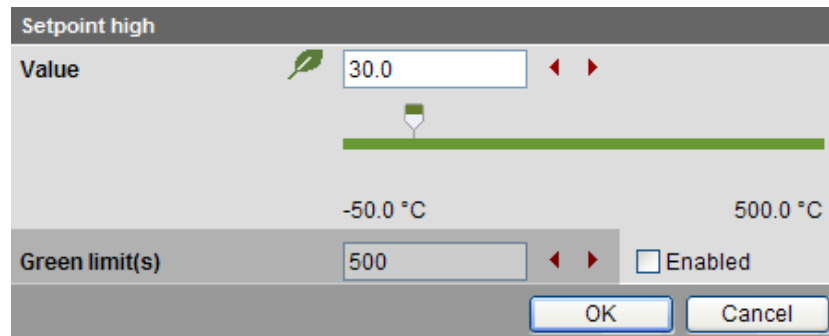

The screenshot shows a dialog box titled "Setpoint high". It features a "Value" field with a green leaf icon and a text input containing "30.0", flanked by red left and right arrow buttons. Below this is a horizontal slider bar with a green track and a white handle. The slider's range is from -50.0 °C to 500.0 °C. At the bottom, there is a "Green limit(s)" field with a text input containing "500", also flanked by red arrow buttons. To the right of this field is a checkbox labeled "Enabled", which is currently unchecked. At the very bottom are "OK" and "Cancel" buttons.

Dialog boxes with variable unit data points contain a disabled checkbox  to set the "Green limit". The entry field and the arrows  are grayed and the "Green limit" slider is hidden. The entire setting range bar is green.

The checkbox  can be enabled with "Administrator" access rights. The "Green limit" can be set and the "Value" (data point value) is compared to the "Green limit".

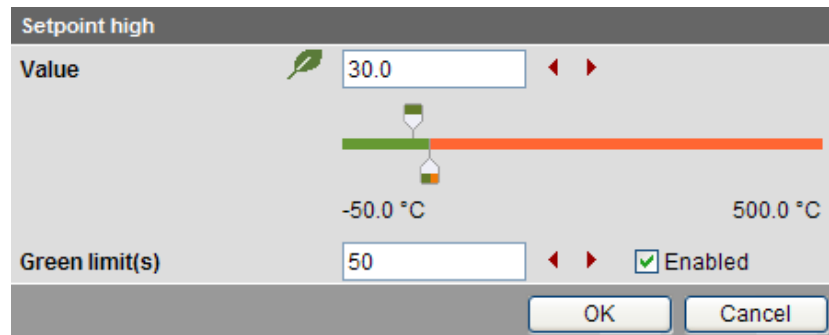

This screenshot is similar to the one above, but the "Green limit(s)" field now contains "50" and the "Enabled" checkbox is checked. The slider bar now has an orange track, and the white handle is positioned at the "50" mark. The "Value" field still contains "30.0". The "OK" and "Cancel" buttons are at the bottom.

## 6.4.5 Dialog boxes for data points with manually set value

The device presets the value during normal operation. You can manually set the value as an exception.

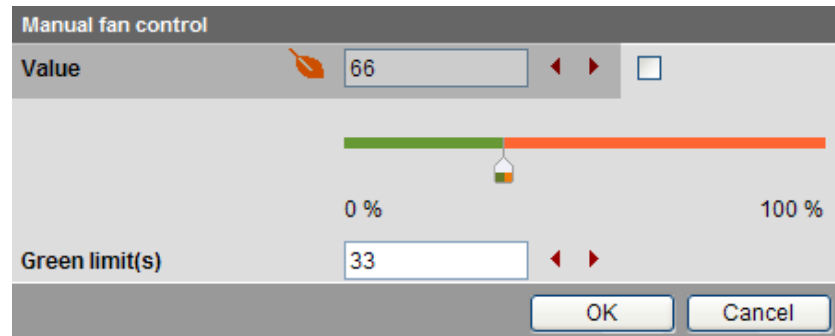

Dialog boxes for data points with a manually set value contain a checkbox. The value cannot be entered manually if the checkbox is cleared . The entry field and the arrows ◀ ▶ are grayed and the "Value" slider is hidden.

The value can be set if the checkbox is selected . The value is then also compared to the "Green limit".

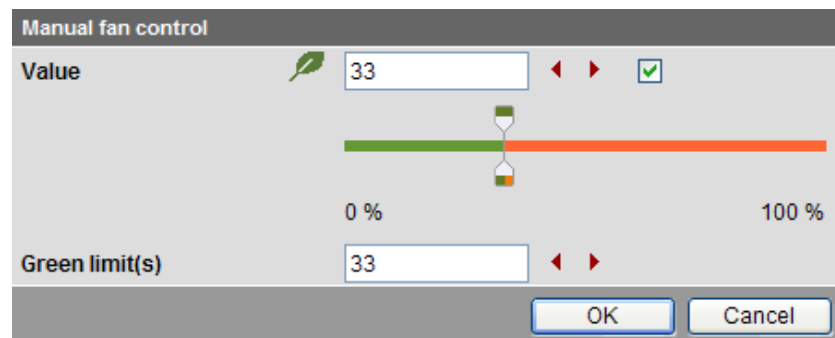

## 6.4.6 User groups "Service" and "End user"

The dialog boxes for the "Energy indicator" data points can be opened also in the "Service" and "End user" user groups.

However, contrary to the "Administrator" user groups, only data point values can be set, not "Green limits".

The entry fields for the "Green limits" are grayed, i.e. they are unavailable for editing. Other than that, the dialog boxes are the same as for the "Administrator" user group.

### Comfort heating setpoint

**Comfort heating setpoint**

Value  21.0 ◀ ▶

20.0 °C 24.0 °C

Green limit(s) 22.0 ◀ ▶

OK Cancel

### Readjustment room unit

**Readjustment room unit**

Value  0.0 ◀ ▶

-3.0 K 3.0 K

Green limit(s) ± 1.0 ◀ ▶

OK Cancel



### Preselection operating mode

Contrary to the "Administrator" user group, the dialog box "Preselection" contains grayed enumeration values (operating modes).

User groups "Service" and "End user" thus can only read, but not change the set "Green limits".

**Preselection**

Value Auto ▾

Green limit(s)  

Auto

Comfort

Precomfort

Economy

Protection

OK Cancel



## 6.5 E-mail with "Energy indicator" for the plant

### 6.5.1 E-mail receiver configuration

Either **no** E-mail (no transmit time = Default) or one or two e-mails (Transmit time 1 and/or Transmit time 2) can be sent with the plant's "Energy indicator".

#### E-mail receiver configuration

E-mail receivers 1 and 2 can be configured with "Administrator" and "Service" access rights on the web server.

Path: OZW772.xx > Settings > Energy indicator

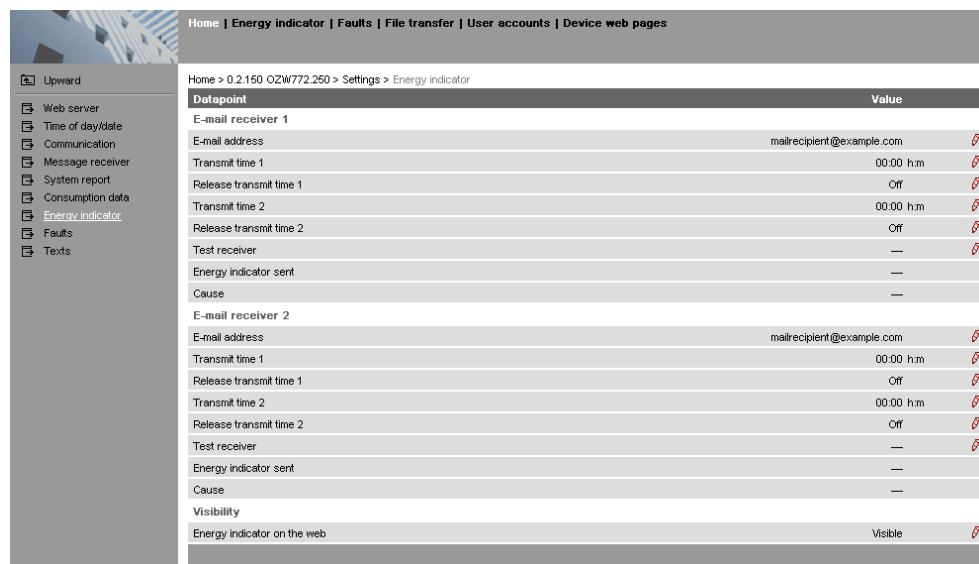

The screenshot shows a web interface for configuring the 'Energy indicator'. The breadcrumb path is 'Home > 0.2.150 OZW772.250 > Settings > Energy indicator'. A left sidebar contains a tree view with 'Energy indicator' selected. The main content area displays a table with two sections for 'E-mail receiver 1' and 'E-mail receiver 2'. Each section has fields for 'E-mail address', 'Transmit time 1', 'Release transmit time 1', 'Transmit time 2', and 'Release transmit time 2'. There are also 'Test receiver', 'Energy indicator sent', and 'Cause' fields. A 'Visibility' section at the bottom shows 'Energy indicator on the web' set to 'Visible'.

Datapoint	Value
E-mail receiver 1	
E-mail address	mailrecipient@example.com
Transmit time 1	00:00 h:m
Release transmit time 1	Off
Transmit time 2	00:00 h:m
Release transmit time 2	Off
Test receiver	—
Energy indicator sent	—
Cause	—
E-mail receiver 2	
E-mail address	mailrecipient@example.com
Transmit time 1	00:00 h:m
Release transmit time 1	Off
Transmit time 2	00:00 h:m
Release transmit time 2	Off
Test receiver	—
Energy indicator sent	—
Cause	—
Visibility	
Energy indicator on the web	Visible

#### Notes

E-mail receivers 1 and 2 are configured individually (separate settings).

If Transmit time 1 and/or 2 are configured, the "Energy indicator" of the plant is sent as an e-mail **only** if at least one monitored data point exceeds its "Green limit".

Configuration of e-mail receivers 1 and 2 for the "Energy indicator" of the plant is not related to the e-mail receivers of fault messages (device failure etc.) and ECA (Energy Cost Allocation).

#### Test receiver

One e-mail each can be sent for test purposes to E-mail receiver 1 and 2.

- The test is triggered manually via data point "Test receiver = Trigger".
- Reception is confirmed in data point "Energy indicator transmitted = Yes".
- Data point "Reason" contains feedback on whether the e-mail was sent or which setting must be checked in the event of an error.

"Energy indicator transmitted" and "Reason"

The values of the data points "Energy indicator transmitted" and "Reason" are displayed after testing until:

- Another test is triggered manually.
- The next transmitted e-mail is transmitted as per Transmit time 1 and/or 2.
- The device supply is switched on and off.

Data point	Function
Test receiver	[ ---, trigger]
"Energy indicator transmitted"	[ ---, Yes, No]
Reason	[ ---, DNS setting, mail server address, mail server port number, e-mail address Receiver, mail server authentication, network cable]

Note

Manual triggering for test purposes does not trigger a fault message.

### Fault message e-mail

If an e-mail with "Energy indicator" of the plant is not transmitted without error, a fault message is triggered for the corresponding e-mail Receiver.

Reset fault message

The fault message is reset if:

- The next transmitted e-mail is transmitted as per Transmit time 1 and/or 2.
- Manually triggered "Test receiver" is successful.

Note

The diagnostic options are identical to those of other e-mail Receivers.

## 6.5.2 Mail inbox

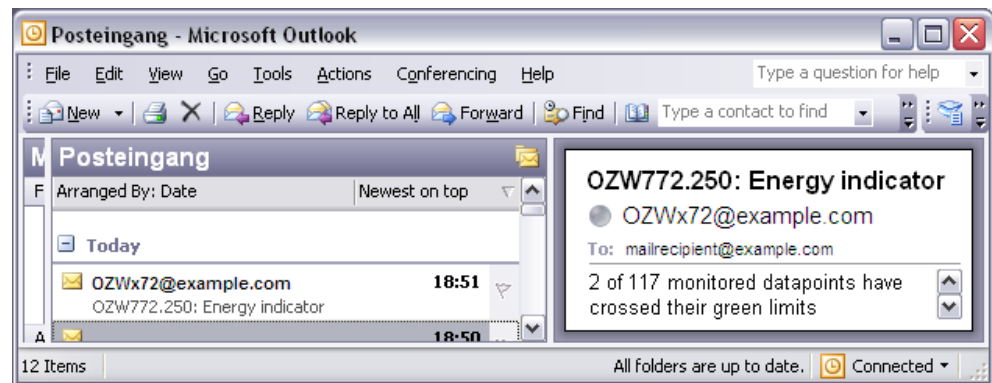

### 6.5.3 E-mail contents

#### E-mail Energy indicator contents

The contents of the e-mails comprises (see screenshot below):

- E-mail format Text only (see message field below).
- E-mail sender As per the settings (e.g. ozw772@siemens.com).
- E-mail Receiver As per the settings (e.g. [first name.lastname@example.com](#)).

#### Reference field

The Reference field comprises the following information:

- Plant name: OZW type or user-defined name (see examples).
- Energy indicator Fixed text (e.g. "Energy indicator" translated into the language selected in the web server).

#### Examples

OZW772.250: Energy indicator

Lindenmatt 1: Energy indicator

#### Message field

The actual message is written in the language selected in the web server.

#### Example

2 of 117 monitored data points have crossed their Green limits.

10 lines follow this text where each line may contain a free text regardless of the language selected in the web server. (Signature line 1...10, with max. 49 characters per line).

#### E-mail "Energy indicator"



## 6.6 Exceptions

### Regenerate bus devices

The following applies to the "Energy indicator" function when regenerating bus devices:

- Existing data points and their "Green limits" as well as the set status for "Data point monitoring activated/deactivate" remain as is.
- Data points no longer available and their "Green limits" are deleted from the "Energy indicator" database.
- New data points and their "Green limits" are taken over into the "Energy indicator" database and data point monitoring is activated.

### Bus devices

#### Hide

Hiding bus devices is the same as deactivating monitoring. Thus, "Energy indicators" are not calculated and displayed.

Home | Energy indicator | Faults | File transfer | User accounts | Device web pages

Device name	Device address	Device type	Serial no	State	Generated on
<input type="checkbox"/> OZW772.250	0.2.150	OZW772.250	00FD00FF0644	Generated	08.03.2012 07:55
<input type="checkbox"/> QAX913	0.2.200	QAX913-DE	00FD000763FE	Generated	08.03.2012 08:03
<input type="checkbox"/> RMH760B-1	0.2.210	RMH760B-1	00FD0007A091	Generated	08.03.2012 08:08
<input type="checkbox"/> RMU730B-1	0.2.220	RMU730B-1	00FD0007980B	Generated	08.03.2012 08:06
<input type="checkbox"/>				<input type="button" value="Add"/> <input type="button" value="Delete"/> <input type="button" value="Generate"/> <input type="button" value="Hide"/>	

#### Generate again

Bus devices are shown again via "Generate".

#### Change configuration

Complete changes to the configuration via "Generate".

#### Replace

Complete bus device replacements via "Generate".

#### Delete

When deleting bus devices from the device list, the "Energy indicator" data is deleted also.

### Special cases

#### Bus device failure

In the event of bus device failure, e.g. no communication via KNX bus, the "Grey leaf" is displayed. The "Estimated processing time" does not change.

#### Missing bus supply

If there is no bus supply, the data point values of the bus devices cannot be read and a "Grey leaf" is displayed. The "Estimated processing time" does not change.

#### System data update

Complete system data updates for all bus devices via "Generate". "Generate" does not lead to data loss.

#### Firmware update

In the event of a firmware update, the entire configuration is lost, i.e. parameter set and data for the "Energy indicator" function.

Read and write of the parameter set via ACS790 allow for retaining the configuration of the OZW772 (device list and "Device Descriptions").

Changed data of the "Energy indicator" function are lost. The "Energy indicator" function starts with the data point values and "Green limits" similar to creating a device list in the web server.

# 7 Communications

## 7.1 Remote operation

The web server can be operated from a PC with web browser on a local area network (LAN) or via the Internet. The following settings also apply to access via Smartphone and other apps via Web API.

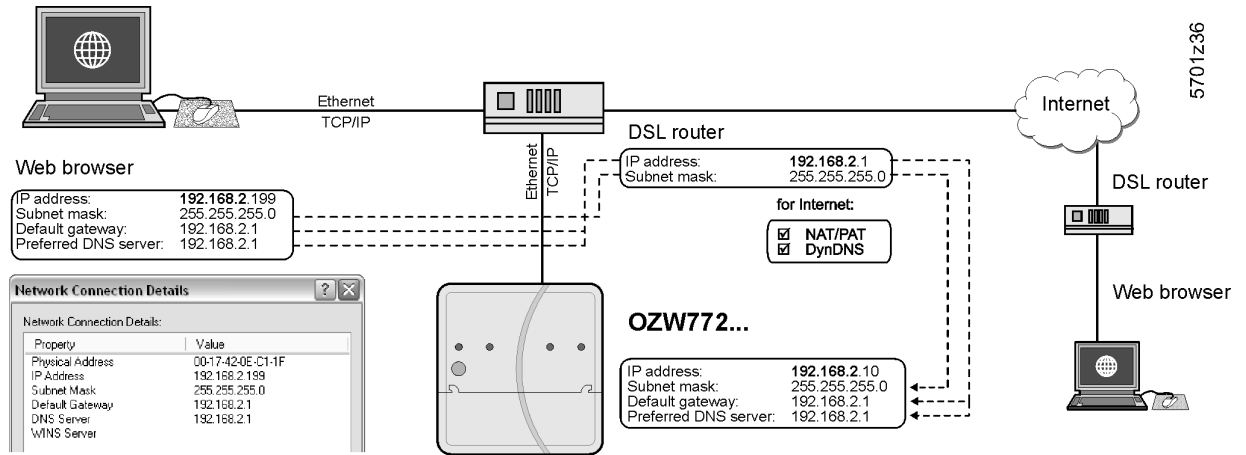

### 7.1.1 Local area network (LAN)

The PC and web server must be on the same IP subnet to communicate. You must first determine the subnet as well as the IP addresses.

#### Local area network with router

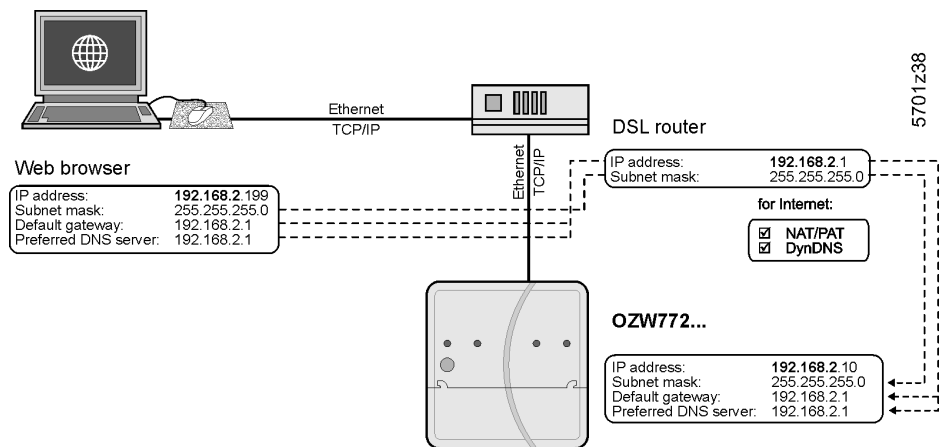

A router normally serves as the DHCP server if installed on a local area network (e.g. DSL router for Internet access). As such, it automatically assigns IP addresses to all participants that are DHCP clients.

If a PC is connected to the router via Ethernet, an IP address, subnet mask, standard gateway and DNS server are assigned automatically.

When delivered, the web server already contains an enabled DHCP client; as a result, users do not need to enter Ethernet settings.

The connection is checked every 3 minutes. It is recommended to assign the IP address of the web server in the router according to its MAC address.

If the router with DHCP server is not available, the web server uses the default IP address [192.168.2.10](http://192.168.2.10).

For manual settings, use the PC to determine the required data.

Procedure:

1. Select *Start > Control Panel > Network connections > Local Area Connection*.
2. Select "Support" tab.

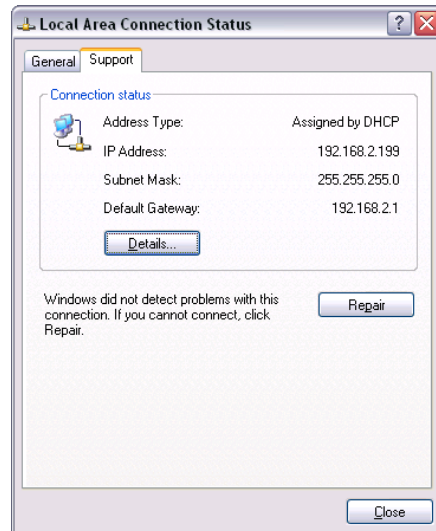

3. Click [ Details... ]

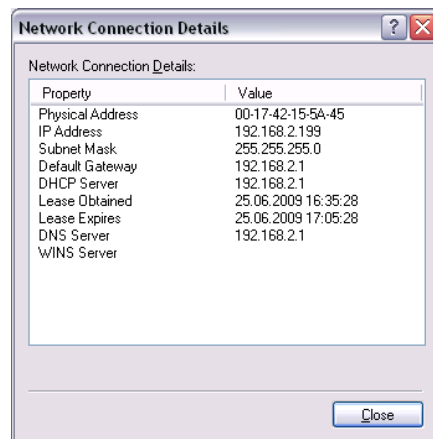

In the example, the PC is assigned the IP address [192.168.2.199](#) and subnet mask [255.255.255.0](#). The default gateway and DNS server have IP address [192.168.2.1](#).

You can use the data to set the web server:

- IP address: an unused address on the subnet. For example [192.168.2.10](#) is still available, if the PC uses [192.168.2.199](#) and the router uses [192.168.2.1](#).
- Subnet mask: [255.255.255.0](#)
- Default gateway: [192.168.2.1](#)
- Preferred DNS server: [192.168.2.1](#)
- Alternate DNS server (empty).

Notes



- In the example, the subnet has an address of [192.168.2.x](#). Devices must have the same subnet address to communicate directly (i.e. without a router).
- The web server is delivered as preconfigured DHCP client with automatic reception of the network configuration. The web server's IP address can be set manually as an option.
- We recommend using IP addresses from the private range in the home network (see Section 10.3.1).

## Local area network without router

IP addresses and subnet masks must be entered manually if a local area network is installed with PC and web server, but without a router.

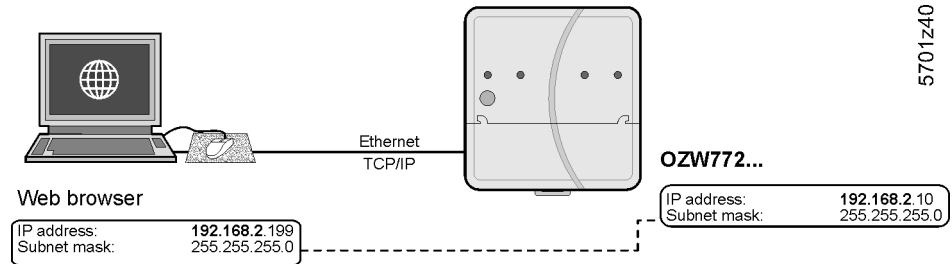

On the PC, set as follows:

1. Select *Start > Control Panel > Network connections > Local Area Connection*.
2. Select the "General" tab.



3. Click [ Properties ]

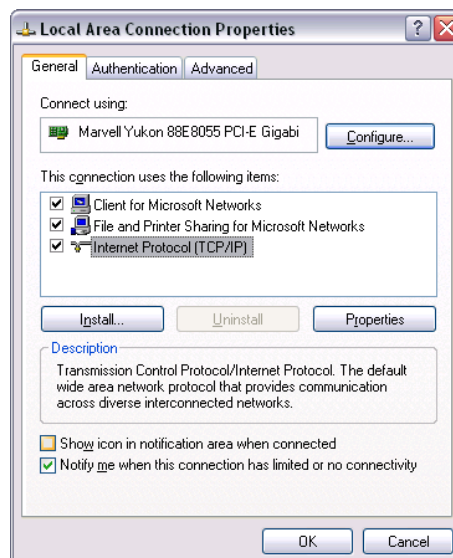

4. Select "Internet Protocol (TCP/IP)".
5. Click [ Properties ]
6. Select "Use the following IP address".

Continued on next page.

7. Enter the IP address and subnet mask.

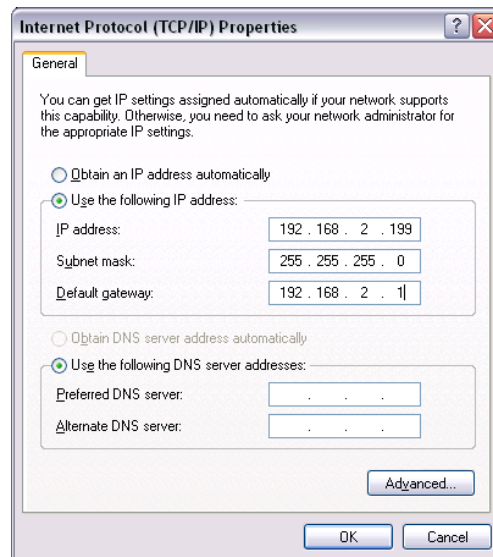

8. Click [ OK ]

In the example, the PC is assigned IP address [192.168.2.199](#) and subnet mask [255.255.255.0](#).

You can now set the web server:

- IP address: An unused address in subnet, e.g. [192.168.2.10](#)
- Subnet mask: [255.255.255.0](#)
- Default gateway (empty).
- Preferred DNS server (empty).
- Alternate DNS server (empty).

## Notes



- In the example, the subnet has an address of [192.168.2.x](#). Devices must have the same subnet address to communicate directly (i.e. without a router).
- Settings for the standard gateway and DNS servers are irrelevant in a local area network without a router.
- We recommend using IP addresses from the private range in the home network (see Section 10.3.1).



## 7.1.2 Remote operation via the Internet

### Internet connection

An appropriate connection is required (e.g. DSL router) for remote operation via Internet. Setting up Internet access is not described here. The web server is not suitable for connecting directly to the Internet, since it does not have a firewall. This is normally a component of the DSL router.

### Notes



- The examples here were created using the Siemens Gigaset SX763 router (see Section 10.3.5). Workflow, terms and functionality may differ when using other products.



- The router must support NAT/PAT, DynDNS and DHCP.
- The web server supports HTTPS (Hyper Text Transfer Protocol Secure) as an option. Web operating pages are transmitted secured and encrypted.

### Local area network (LAN)

IP address, subnet mask and DHCP are set up under Local Network in addition to other settings:

- The IP address router is fixed.
- The subnet mask defines the size of the subnet.
- The router assigns the DHCP clients (e.g. the PC on the local area network) an IP address from a selecting setting range ("First issued IP address" through "Last issued IP address") if set as DHCP server.
- The "Standard gateway" is typically the router's IP address as well.
- The "Lease time" defines how long a client maintains the IP address received from the DHCP server (the DHCP server regularly renews the client IP addresses).

### Gigaset SX763 WLAN dsl

The screenshot shows the 'Local Network' configuration page in the Gigaset SX763 web interface. The page is titled 'Local Network' and has a navigation menu on the left with options: Internet, Local Network (selected), Wireless Network, Telephony, USB, and Administration. The main content area contains the following settings:

- IP address: 192 . 168 . 2 . 1
- Subnet mask: 255 . 255 . 255 . 0
- DHCP Server:  On  Off
- Lease time: 30 minutes
- First issued IP address: 192 . 168 . 2 . 100
- Last issued IP address: 192 . 168 . 2 . 199
- Default gateway: 192 . 168 . 2 . 1
- Preferred DNS server: [ ] . [ ] . [ ] . [ ]
- Alternate DNS server: [ ] . [ ] . [ ] . [ ]
- Domain name: dummy.porta.siemens.net
- Clients table with columns for MAC address and IP address, and an 'Add' button.

Buttons for 'OK' and 'Cancel' are at the bottom of the form.

SIEMENS

In the example, the router has a set IP address of [192.168.2.1](#) and receives subnet mask [255.255.255.0](#). As a DHCP server, it renews the IP addresses of the DHCP clients every 30 (in the above example) minutes. DHCP clients are assigned addresses from a range of [192.168.2.100](#) through [192.168.2.199](#). The router is the gateway between LAN and Internet.

## Firewall

We recommend enabling the firewall to protect the local area network:

- Firewall: On

## Gigaset SX763 WLAN dsl

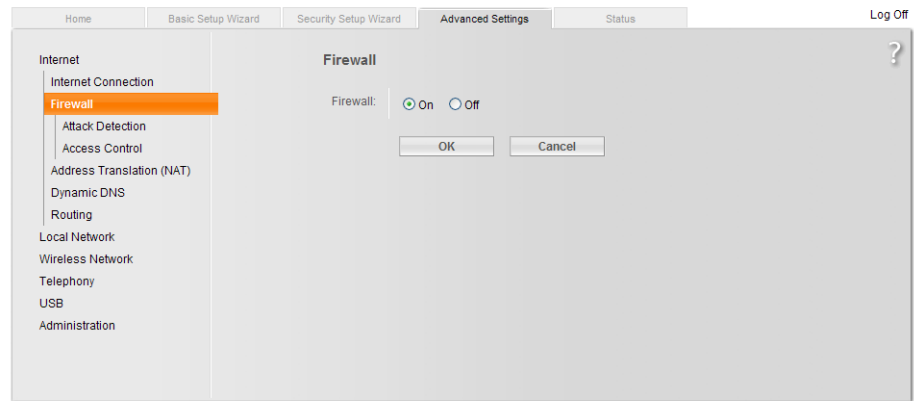

SIEMENS

## Address translation (NAT)

Activate NAT to ensure that the web server can be reached via the Internet:

- NAT: On

## Gigaset SX763 WLAN dsl

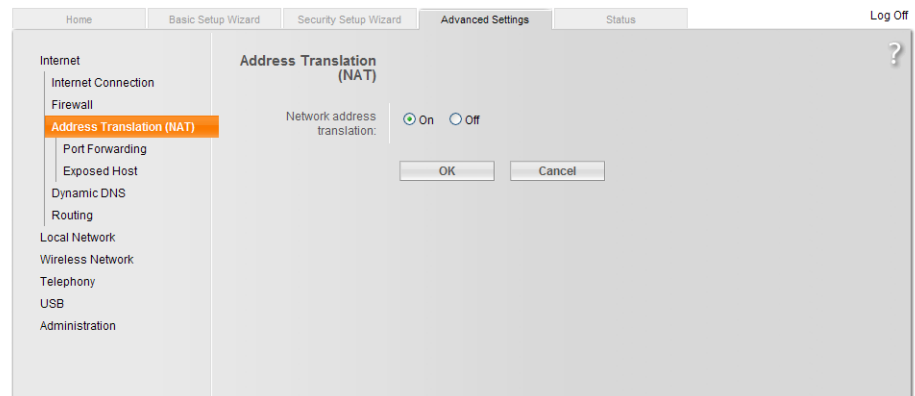

SIEMENS

## Port forwarding (PAT)

- Port Forwarding is used to determine which local IP addresses/ports the router translates to which public IP addresses/ports.
- Web operating pages are preset on the web server via Port 80 (HTTP) or port 443 (HTTPS). As a result, queries from the Internet must be translated using the public IP address/port to the private IP address/port 80 or 443 for the web server.
- If the connection of the software ETS Tool is via the Internet, Port 3671 (reserved for ETS) must be translated by public as well as private IP addresses.
- When using PC software ACS790 for remote operation, you must also change Port 21 (FTP) and Port 50005 (ACS private) from the public to a private IP address.

## Notes



- The port IP address is appended to the web browser address line: <IP address>:<Port>, e.g. [122.104.2.10:8080](http://122.104.2.10:8080).
- The web browser always uses port 80 unless another port is entered. As a result, the information in the address line for the web browser is always: <IP address>:80 and <IP address>, or [122.104.2.10:80](http://122.104.2.10:80) and [122.104.2.10](http://122.104.2.10).
- Ports not equal to 80 are considered more robust against hackers.
- We recommend using Port Forwarding from the private range for ports (see Section 10.3.1).

## Gigaset SX763 WLAN dsl

Protocol	Public port	Local port	Local IP address	Comment	Enabled
TCP	80	80	192 . 168 . 2 . 10	OZW772 HTTP	<input checked="" type="checkbox"/>
TCP	21	21	192 . 168 . 2 . 10	OZW772 FTP	<input checked="" type="checkbox"/>
TCP			192 . . . .		<input checked="" type="checkbox"/>
Predefined applications:	FTP	192 . . . .		FTP	<input checked="" type="checkbox"/>

SIEMENS

In the example, queries from the Internet to a public IP address (Internet connection)/port 80 are forwarded to local IP address [192.168.2.10](http://192.168.2.10) (web server)/Port 80. Port 21 is also enabled for file transfer.

## DynDNS

The web server can communicate directly with the fixed IP address or domain if a fixed IP address or domain (e.g. [www.myname.com](http://www.myname.com)) is available for the Internet connection.

## Dynamic IP address

For dynamic IP addresses, the Internet provides free-of-charge DynDNS services that connect user-defined domain names to dynamic IP addresses. The router must support DynDNS to use this function.

## Registration

To use the DynDNS service, a new account must be set up at the respective provider.

## Report dynamic address

The router must inform the service of changes to the dynamic IP address for the web server to communicate via the DynDNS service setup. Set up the router DynDNS as follows:

- Dynamic DNS: On
- Service provider: Service provider.
- Domain name Domain = Host name (own name).
- User name: User name for the DynDNS account (e.g. MyUserAccount).
- Password: Password for DynDNS account.

## Gigaset SX763 WLAN dsl

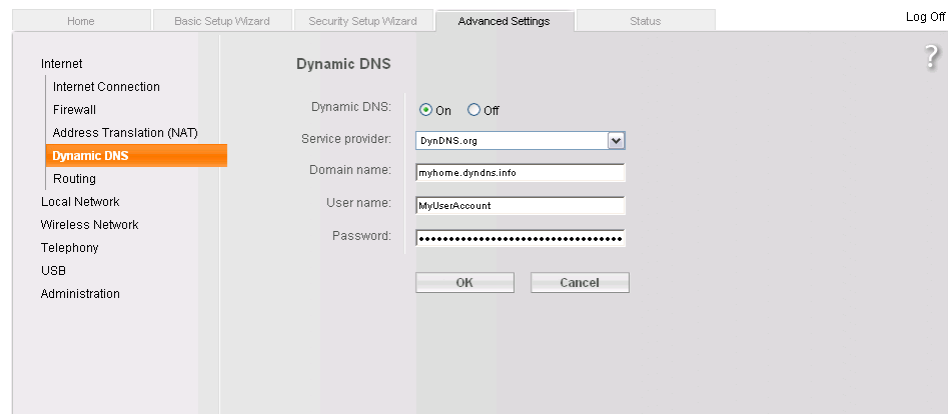

SIEMENS

## Encrypted connection (HTTPS)

HTTPS encryption via port 443 is also supported. The required certificate is not accredited. The self-signed certificate from Siemens is valid for 20 years and is installed on the web server. The certificate must be installed on the web browser for encrypted communications.

## Note



One own certificate must be installed for each web server.

## Principal workflow

The web browser security warning is displayed the first time you connect via the **https** address. The page continues to load contrary to the web browser recommendation.

The certificate must now be installed: A context-sensitive installation routine is available depending on web browser used.

## Note



The warning "Certificate error" remains for individual web browsers even after the certificate is successfully installed. Transmission is nevertheless secure.

## 7.2 Messages via e-mail

### E-mail

SMTP is used to send fault messages, system reports and consumption data via e-mail. The mail server (SMTP server, outgoing mail server) must be known to the web server to send e-mails to the Receivers (see Section 2.5.2, E-mail).

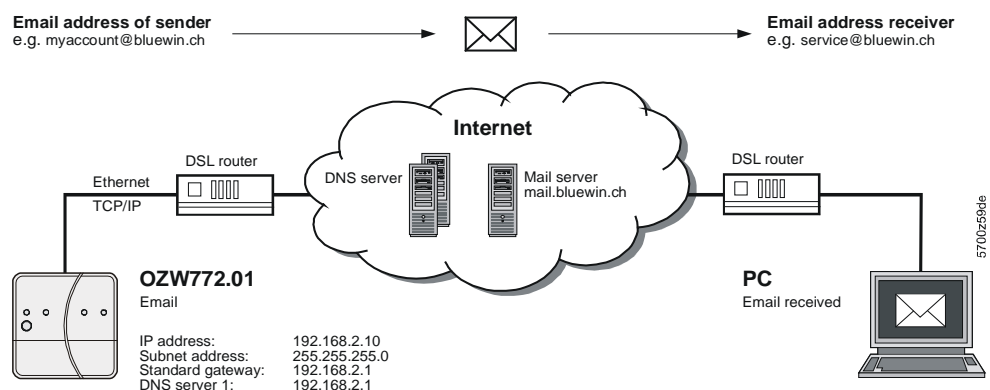

Prerequisites for sending e-mails via Internet:

- An e-mail account is available and set up (see Section 10.3.2, Free e-mail account providers ).
- Internet access is set up for the web server (see Section 7.1.2).
- The settings for "E-mail", "Message receiver 1...4", "System report" or "Consumption data > Receiver" are made (see Section 2.5.2).

Example of an e-mail  
(fault message)

```
Von: myhome@bluewin.ch Gesendet: Mi 05.01.2011 16:12
An: service@siemens.com
Cc:
Betreff: OZW772.16: Message central comm unit

Device: OZW772.16 (0.2.150)

Message: >1 clock time mast

Fault number: 5002

Fault priority: Not urgent

Time of occurrence: 05.01.2011; 16:12

Signatur 1
```

Example of an e-mail  
(consumption data)

```
Von: myhome@bluewin.ch Gesendet: Di 04.01.2011 11:48
An: service@siemens.com
Cc:
Betreff: OZW772.16: Consumption data
Anlagen: OZW772.16_20110104.xml (17 KB)

Signatur 1
```

E-mail outline depends on message type and content.  
In the listing below:

- User settings are in bold.
- The path for user settings starts each time with:  
Home > 0.2.252 OZW772.16 > Settings > ...
- Set components of the e-mail are in italics.

## Web server fault

Example of an e-mail	Data point, information
<i>From:</i> <b>myhome@bluewin.ch</b>	...> Communication > E-mail: <b>E-mail address sender</b>
<i>To:</i> <b>service@siemens.com</b>	...> Message receiver > Message receiver 1...4: <b>E-mail address</b>
<i>Subject:</i> <b>OZW772.16: Message central unit</b>	...> Texts: <b>Name:</b> Message type
<i>Device:</i> <b>OZW772.16</b> (0.2.252) Message: No bus power supply <i>Fault number:</i> 5000 Fault priority: Urgent Occurred at: 07-Oct-2010 at 3:15 pm	...> Texts: <b>Name</b> (Device address) Fault text Fault code Fault priority Occurred at
<b>myhome.dyndns.info</b>	...> Communication > E-mail: <b>Signature line 1...10</b>

## Fault Synco device

Example of an e-mail	Data point, information
<i>From:</i> <b>myhome@bluewin.ch</b>	...> Communication > E-mail: <b>E-mail address sender</b>
<i>To:</i> <b>service@siemens.com</b>	...> Message receiver > Message receiver 1...4: <b>E-mail address</b>
<i>Subject:</i> <b>OZW772.16: Message central unit</b>	...> Texts: <b>Name:</b> Message type
<i>Device:</i> QAX913 (0.2.250) Message: No bus power supply <i>Fault number:</i> 5002 <i>Fault priority:</i> Not urgent Occurred at: 07-Oct-2010 at 3:23 pm	Name Synco device (device address) Fault text Fault code Fault priority Occurred at
<b>myhome.dyndns.info</b>	...> Communication > E-mail: <b>Signature line 1...10</b>

Fault eliminated

Example of an e-mail	Data point, information
<i>From:</i> <b>myhome@bluewin.ch</b>	...> Communication > E-mail: <b>E-mail address sender</b>
<i>To:</i> <b>service@siemens.com</b>	...> Message receiver > Message receiver 1...4: <b>E-mail address</b>
<i>Subject:</i> <b>OZW772.16: Message central unit</b>	...> Texts: <b>Plant name:</b> Message type
<i>Device:</i> <b>OZW772.16</b> (0.2.252) or QAX913 (0.2.250) <i>Message:</i> No fault <i>Fault number:</i> 00 <i>Fault priority:</i> Not urgent Occurred at: 07-Oct-2010 at 3:23 pm	...> Texts: <b>Plant name</b> (device address) or Name Synco device (device address) Fault text Fault code Fault priority Occurred at
<b>myhome.dyndns.info</b>	...> Communication > E-mail: <b>Signature line 1...10</b>

System report with fault

Example of an e-mail	Data point, information
<i>From:</i> <b>myhome@bluewin.ch</b>	...> Communication > E-mail: <b>E-mail address sender</b>
<i>To:</i> <b>service@siemens.com</b>	...> Message receiver > Message receiver 1...4: <b>E-mail address</b>
<i>Subject:</i> <b>OZW772.16: System report central unit</b>	> Texts: <b>Plant name:</b> Message type
<i>Status:</i> N. OK <i>Fault 1:</i>  <i>Device:</i> QAX913 (0.2.250) <i>Message:</i> *No bus power supply, 5002 Occurred at: 07-Oct-2010 at 3:42 pm	Status Fault 1:  Name Synco device (device address)  Fault text, fault code Occurred at
<b>myhome.dyndns.info</b>	...> Communication > E-mail: <b>Signature line 1...10</b>

System report  
without fault

Example of an e-mail	Data point, information
<i>From:</i> <b>myhome@bluewin.ch</b>	...> Communication > E-mail: <b>E-mail address sender</b>
<i>To:</i> <b>service@siemens.com</b>	...> Message receiver > Message receiver 1...4: <b>E-mail address</b>
<i>Subject:</i> <b>OZW772.16: System report central unit</b>	...> Texts: <b>Plant name:</b> Message type
<i>Status:</i> OK	Status
<b>myhome.dyndns.info</b>	...> Communication > E-mail: <b>Signature line 1...10</b>

Consumption data

Example of an e-mail	Data point, information
<i>From:</i> <b>myhome@bluewin.ch</b>	...> Communication > E-mail: <b>E-mail address sender</b>
<i>To:</i> <b>service@siemens.com</b>	...> Consumption data > Message receiver > E-mail receiver 1...2 > <b>E-mail address</b>
<i>Subject:</i> <b>OZW772.16: Consumption data</b>	...> Texts: <b>Plant name:</b> Message type
<i>Plants:</i>	.xml or .csv file
<b>myhome.dyndns.info</b>	...> Communication > E-mail: <b>Signature line 1...10</b>



## MS Outlook

You can provide the required information as follows for an e-mail account under MS Outlook:

1. Start Outlook.
2. Go to Tools / E-mail accounts...
3.  View or change existing e-mail accounts.
4. Click [ Next > ]
5. Select the desired account.
6. Click [ Change ]

The e-mail account dialog box is displayed with the data on the e-mail account.

The screenshot shows the 'E-mail Accounts' dialog box with the following fields and options:

- User Information:** Your Name: myname; E-mail Address: myaccount@bluewin.ch
- Server Information:** Incoming mail server (POP3): pop.bluewin.ch; Outgoing mail server (SMTP): mail.bluewin.ch
- Logon Information:** User Name: myaccount@bluewin.ch; Password: \*\*\*\*\*;  Remember password
- Test Settings:**  Log on using Secure Password Authentication (SPA); Test Account Settings ...; More Settings ...

Navigation buttons at the bottom: < Back, Next >, Cancel.

7. Click [ More settings... ]  
If required, authentication is displayed here.

The screenshot shows the 'Internet E-mail Settings' dialog box, 'Outgoing Server' tab. The following options are visible:

- My outgoing server (SMTP) requires authentication
- Use same settings as my incoming mail server
- Log on using:  
User Name: [ ]  
Password: [ ]  
 Remember password
- Log on using Secure Password Authentication (SPA)
- Log on to incoming mail server before sending mail

Buttons at the bottom: OK, Cancel.

8. Click [ Cancel ] to exit the account settings.

## Notes



- A list of providers that send e-mails at no charge is available in Section 10.3.2.
- The web server supports HTTPS (Hyper Text Transfer Protocol Secure). E-mails are transmitted unsecured and unencrypted.
- Web server supports SSL (Secure Sockets Layer, network protocol for the secure transfer of data) and TLS (Transport Layer Security, encryption protocol for data transmissions over the Internet; a further development of SSL).
  - "Authentication mail server = Yes" checks unsecured, unencrypted information in the data items "User name" and "Password" from the mail server for each e-mail transmission.
- The mail server can also be installed on the local area network.

# 8 Trend functions

## 8.1 Overview

The Web-Server OZW772... can create trends for any data points. The trend can be labeled with its own name and the sampling rate set. The maximum period of trending is derived from the number of data points selected and the sampling rate. A web browser is used to set the trend. As an alternative, you can also set trends via the ACS Tool.

### Select trend function

1. Select the web server.  
The **Home** page is displayed.

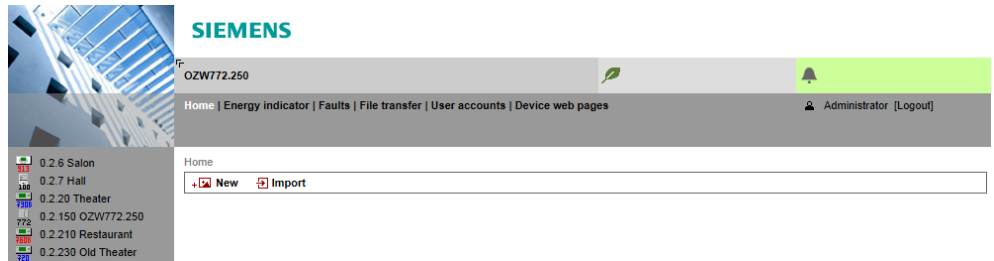

2. Under primary navigation, select **File transfer** menu.

Home | Energy indicator | Faults | **File transfer** | User accounts | Device web pages

In secondary navigation on the left side of the window, the overview page **Trend** for the web server is automatically selected.

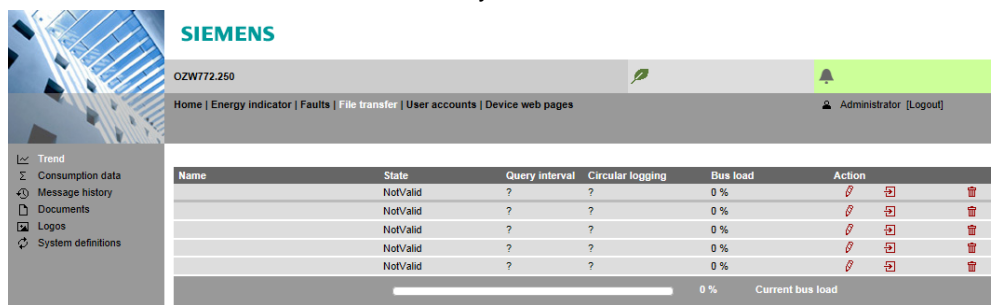

Trend overview appears as follows if not trend has been defined:

Name	State	Query interval	Circular logging	Bus load	Action
	NotValid	?	?	0 %	[Edit] [Delete]
	NotValid	?	?	0 %	[Edit] [Delete]
	NotValid	?	?	0 %	[Edit] [Delete]
	NotValid	?	?	0 %	[Edit] [Delete]
	NotValid	?	?	0 %	[Edit] [Delete]

0 % Current bus load

Trend overview appears as follows if trends have already been defined:

Name	State	Query interval	Circular logging	Bus load	Action
outside temperature	Running	15m	730 Days	0 %	[Edit]
room temperature	Finished	15m	730 Days	0 %	[Edit] [Delete]
	NotValid	?	?	0 %	[Edit] [Delete]
	NotValid	?	?	0 %	[Edit] [Delete]
	NotValid	?	?	0 %	[Edit] [Delete]

0 % Current bus load

An active trend is highlighted in green.

## Trend information



The following information is displayed for a maximum of 5 trends:

- Name
- Status
- Query interval
- Circular logging (length of the history window)
- Bus load per trend

The sum of the bus load for all active trends is displayed below the table using the "Bus load" bar.

## Buttons

The red symbols in the trend overview are buttons with the following functions:

	Create or edit trend		Import trend definitions
	Start trend recording		Export trend definitions
	Stop trend recording		Delete trend data and trend definitions
	Download trend data		

## Trend states

A trend channel can have the following states:

**Invalid:** Trend is state **invalid** as long as no data points are defined in trend, e.g. in delivery state or after deleting a trend definition.

**Process completed:** The trend is in state "Process completed" as soon as data points are defined that the trend is stopped or not yet started".

**Running:** The trend is in state "In progress" if trend recording is started.

## 8.2 Define trend

### 8.2.1 Define trend via web

You define trends on the trend overview page.

1. Click the red pencil  to create or edit a trend. The **Edit** window opens.

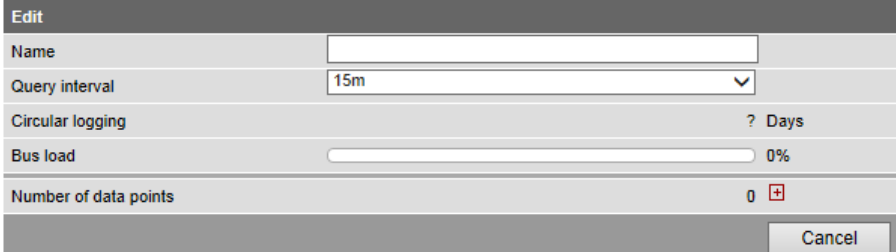

2. Enter trend name.

- Select query interval (1 s, 2 s, 5 s, 10 s, 15 s, 30 s, 1 m, 2 m, 5 m, 10 m, 15 m, 30 m, 1 h, 2 h, 3 h, 6 h, 12 h, 24 h).

- Click **+** to add a data point. The **Data point address** is displayed with available devices.

As of OZW version 5.0, data points integrated in the system via KNX S-Mode (e.g. lighting, blinds, energy and volume measured values) are available to the trend function.

5. To record outside temperature in this example, , the data point "Actual value outside temp" is used under "0.2.230 Old Theater>Inputs" .

**Datapoint address**

Home > 0.2.230 Old Theater > Inputs

Upward

N.X1

N.X2

N.X3

N.X4

N.X5

N.X6

N.X7

N.X8

[Room temperature 1] bus

[Room temperature 2] bus

Actual value room temp

Actual value outside temp

Outside temperature simulation

Cancel

6. The trend settings and the resulting, maximum trend length and bus load is displayed in the window. "Edit" displayed.  
Click  to add up to a maximum of 100 data points.  
To conclude, confirm settings with **OK**.

**Edit**

Name

Query interval

Circular logging 728 Days

Bus load

Number of data points 1

Home > 0.2.230 Old Theater > Inputs: Actual value outside temp

OK Cancel

The trend is created and automatically started.

Name	State	Query interval	Circular logging	Bus load	Action
outside temperature	Running	1m	728 Days	2 %	<input checked="" type="checkbox"/>

## 8.2.2 Restriction to bus load

Bus load by the trend function is restricted to 1 data point per second (corresponding to 100 %). The sum of the loads of all 5 trend channels cannot exceed this value.

No new trends can be started once the value is reached.

In the example below, the query interval of the outside temperature of 1 second already results in a bus load of 100 %. As a consequence, an additional query of the room temperature at 50 % load can no longer be started.

Name	State	Query interval	Circular logging	Bus load	Action
outside temperature	Running	1s	12 Days	100 %	
room temperature	Finished	2s	3 Days	50 %	
	NotValid	?	?	0 %	
	NotValid	?	?	0 %	
	NotValid	?	?	0 %	

100 % Current bus load

Any attempt to start this trend results in a warning.



## 8.2.3 Reset trend definition

Trends can be reset to the default settings.

The default settings for the values are as follows:

- Interval = 15 Min
- Number of data points = 0
- Status = Invalid
- History window = ? days
- Bus load = 0 %
- Trend name = ""

### Note

Any associated trend data is deleted when the trend definition is reset.

### Procedure

1. Click the red waste can symbol   
The confirmation window **Delete** of the trend data opens.

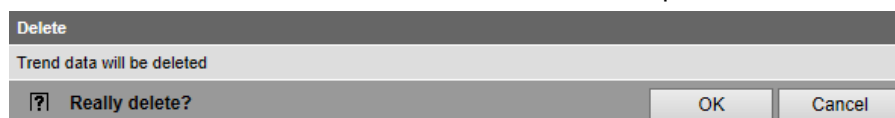



2. Confirm delete of trend data with **OK**.  
The trend settings and data is deleted.

## 8.2.4 Add trend data points





### Add data points

Additional data points are added to an existing trend as follows:















1. Click the red pencil symbol  to open an existing trend. The **Edit** window opens.

Edit	
Name	Trend 1
Query interval	15m
Circular logging	730 Days
Bus load	0%
Number of data points	1 
	Home > 0.2.230 Old Theater > Inputs: Actual value outside temp 
<input type="button" value="OK"/> <input type="button" value="Cancel"/>	

2. Use the plus symbol  to add an additional data point address as data point to the trend. The selected data points are listed in the data point list.

Edit	
Name	Trend 1
Query interval	15m
Circular logging	730 Days
Bus load	0%
Number of data points	2 
	Home > 0.2.230 Old Theater > Inputs: Actual value outside temp 
	Home > 0.2.230 Old Theater > Inputs: Actual value room temp 
<input type="button" value="OK"/> <input type="button" value="Cancel"/>	

3. You can add a maximum of 100 data points to the trend using the plus symbol . Bus load and trend period is adapted to the number of data points accordingly.

Edit	
Name	Trend 1
Query interval	15m
Circular logging	642 Days
Bus load	1%
Number of data points	7 
	Home > 0.2.230 Old Theater > Inputs: Actual value outside temp 
	Home > 0.2.230 Old Theater > Inputs: Actual value room temp 
	Home > 0.2.230 Old Theater > Room operating mode: State 
	Home > 0.2.20 Theater > Settings > Controller 1 > Room setpoints: Comfort cooling setpoint 
	Home > 0.2.20 Theater > Settings > Controller 1 > Room setpoints: Comfort heating setpoint 
	Home > 0.2.20 Theater > Settings > Aggregates > Heat recovery equipment: Positioning signal min 
	Home > 0.2.7 Hall > Inputs: Input X1 
<input type="button" value="OK"/> <input type="button" value="Cancel"/>	

## Notes

The data points within a trend are all queried at the same interval.  
The entire path for a data point is always displayed simply identifying the source of the data point.

## Sort data points

Data points can be moved within the list.  
Simply left-click the sort symbol  for the data point and keep it pressed until the data point is moved to the new position.

## Delete data points from the list

A single left-click of the waste can symbol  deletes the data point from the data point list without additional confirmation.

## 8.2.5 Manage trend RAM

---

A fixed RAM (flash) size is assigned to each trend channel. Trend channel 1 has more RAM and is particularly well suited for long-term trending with a number of data points, or a high query interval.

- Trend channel 1: 14 MB
- Trend channel 2...5: 2 MB

The read data is written first to RAM while trending. It is transmitted to Flash memory every 60 minutes. A maximum of one hour of trend data is lost in the event of a power outage.



## 8.3 Send trend data by e-mail

Trend data can be sent as an appendix to an email.

Settings to sent trend data by e-mail occur in the following area:

1. In primary navigation, click **Home**.
2. In secondary navigation, click **0.x.y OZW...**
3. Click **Settings**.
4. Click **Trend**.

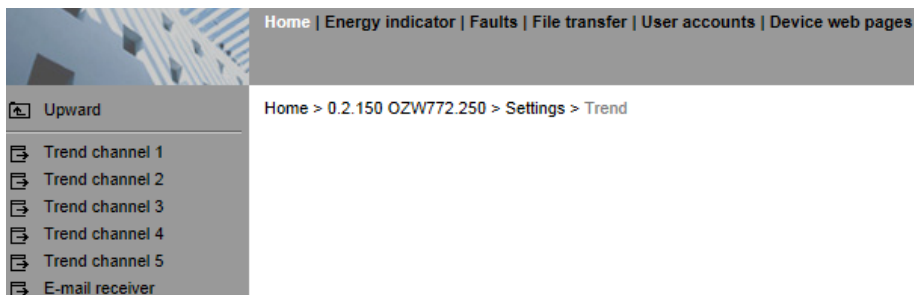

In secondary navigation, the menus **Trend channel 1...5** and **E-mail receiver** are now available.

### 8.3.1 Configure E-mail receiver





OZW can send trend data to a total of 2 e-mail receivers for each trend channel.

The receiver addresses are set as follows:

1. In secondary navigation, click **E-mail receiver**.

The window with the e-mail addresses for both message receivers opens:

Home > 0.2.150 OZW772.250 > Settings > Trend > E-mail receiver

Datapoint	Value
E-mail receiver 1	
E-mail address	mailrecipient@example.com 
Test receiver	--- 
Trend data sent	---
Cause	---
E-mail receiver 2	
E-mail address	mailrecipient@example.com 
Test receiver	--- 
Trend data sent	---
Cause	---

2. Click **E-mail address** of the desired receiver 1 or 2 or the red pencil symbol .

The **Edit** window opens.

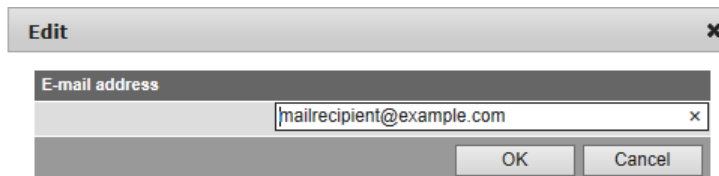

3. Enter the desired e-mail address.
4. Click **OK** to confirm.

## Send test e-mail to receiver

You can send a test e-mail to the receiver to ensure the settings are correct.

1. Click **Test receiver** or the red pencil symbol .
2. In the **Edit** window, select the **Trigger** option.

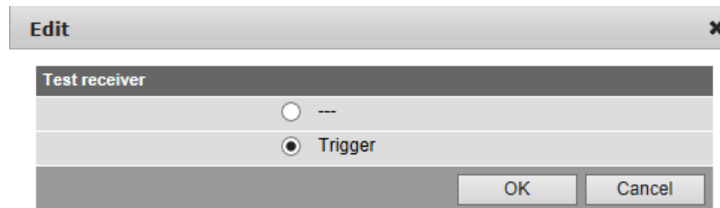

3. Confirm with **OK**.  
OZW sends a test e-mail to the entered receiver and confirms the transmission under the data point **Trend data sent** with **Yes**.  
If transmission failed, a possible cause is provided under **Reason**, see Section **Error! Reference source not found. Error! Reference source not found.**, "Test message receiver".
4. Check whether the e-mail arrived at the receiver.

## Note



E-mail receiver settings are retained when deleting or overwriting an existing trend definition.

## 8.3.2 Sent transmission options per trend channel

The transmit interval can be set separately for each trend channel 1...5.

1. In secondary navigation, select desired **Trend channel 1...5**.  
The window displays name, state, circular logging, transmit interval, and message receiver.

Home > 0.2.150 OZW772.250 > Settings > Trend > Trend channel 1

Datapoint	Value
Trend channel 1	outside temperature
State	Running
Circular logging	730 d
Transmit interval	Automatic 
Message receiver	Receiver 1+2 

## Set transmit interval

1. Click **Transmit interval** or click the red pencil .
- The edit window opens.

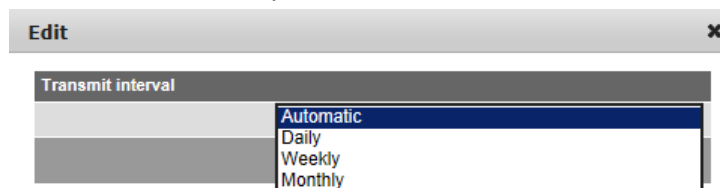

2. Set the desired transmit interval.  
The following options are available:  
**Automatic** (default value): The e-mail is sent after the history window expires. All trend data is sent going back to the start of trend logging.  
**Daily**: An e-mail is sent each day. All trend data is sent from the last day.  
**Weekly**: An e-mail is sent every week. All trend data is sent from the last week.  
**Monthly**: An e-mail is sent each month. Trend data for the last month is sent.
3. Click **OK** to confirm

## Notes

An e-mail is always sent when a trend is stopped.  
An e-mail is only sent while trend logging is on-going.  
This does not interrupt trend logging.  
The data in the OZW RAM is not deleted after the e-mail is sent.

## Set message receiver

1. Click **E-mail receiver** or click the red pencil .  
The edit window opens.

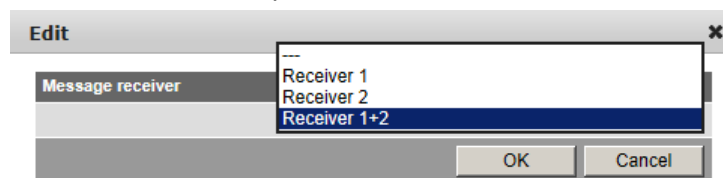

2. Set the desired e-mail receiver for this trend channel.  
The following options are available:  
--- : No transmission of e-mails from this trend channel  
**Receiver 1**: Transmission to receiver 1  
**Receiver 2**: Transmission to receiver 2  
**Receiver 1 + 2**: Transmission to receiver 1 + 2

## 8.3.3 E-mail content and appendix

### E-mail content

The plant and trend name appear in the subject line for the e-mail:

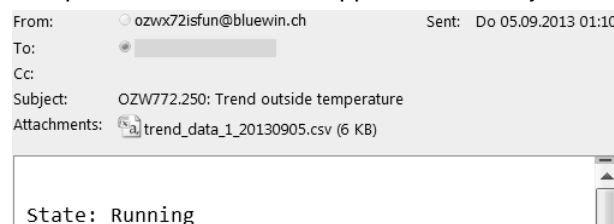

The file name of the appendix is composed as follows:  
- trend\_data\_x\_ (with x representing trend channel 1...5)  
- Creation date (yyyymmdd)

In addition, the text field lists the current status of the corresponding trend:

**State: Running:** Trending is still running.

**State: Completed:** Trending is completed.

## Appendix content

The appendix to the sent e-mail is a .csv (comma-separated values) file and can be opened using a common spreadsheet programs and text editors.

### Example of a view in Excel:

	A	B	C	D	E	F	G	H
1	Plant information							
2								
3	Plant name	Device address	Device type	Serial number	IP address	File created on	File version	
4	OZW772.250	0.2.150	OZW772.250	00FD00FF0B5B	192.168.2.7	02:35 05.09.2013	1	
5								
6	Trend channel 1	outside temperature						
7	Query interval	5m						
8	Beginning	09:44:26	04.09.2013					
9	End	02:34:26	05.09.2013					
10								
11	Date	Time of day	Home > 0.2.230 Old Theater > Inputs: Actual value outside temp					
12	04.09.2013	09:44:26	22.8					
13	04.09.2013	09:49:26	22.8					
14	04.09.2013	09:54:26	23.1					
15	04.09.2013	09:59:26	23.1					
16	04.09.2013	10:04:26	23.1					
17	04.09.2013	10:09:26	23.1					
18	04.09.2013	10:14:26	23.1					
19	04.09.2013	10:19:26	23.3					
20	04.09.2013	10:24:26	23.3					
21	04.09.2013	10:29:26	23.5					
22	04.09.2013	10:34:26	23.5					
23	04.09.2013	10:39:26	22.8					
24	04.09.2013	10:44:26	22.8					

The file includes the following information, in addition to the actual trend data with date, time, and value:

- Plant name
- Device address
- Device type
- Serial number
- IP address
- Date and time of file creation
- File version
- Number and name of the trend channel
- Query interval
- Beginning
- End (last trend item prior to transmitting trend data)
- Path and data point name of trend

## 8.4 Download trend file via web

Trend data can be downloaded via the OZW web user interface.

### Notes

Downloading via the web does not influence transmission of the data by e-mail. Logging of trend data continues unabated while downloading via web.

Trend data is downloaded via web as follows:

1. Under primary navigation, select **File transfer** menu (see Section 8.1 "Overview").
2. For the desired trend, click the symbol **Download trend data** .
3. In the **Period** window, you can set the timeframe to downloading the trend data.



4. Click the calendar symbol  to select the beginning and end of the period and select the desired day.

The period always begins at 00:00 and ends at 23:59 of the selected day.

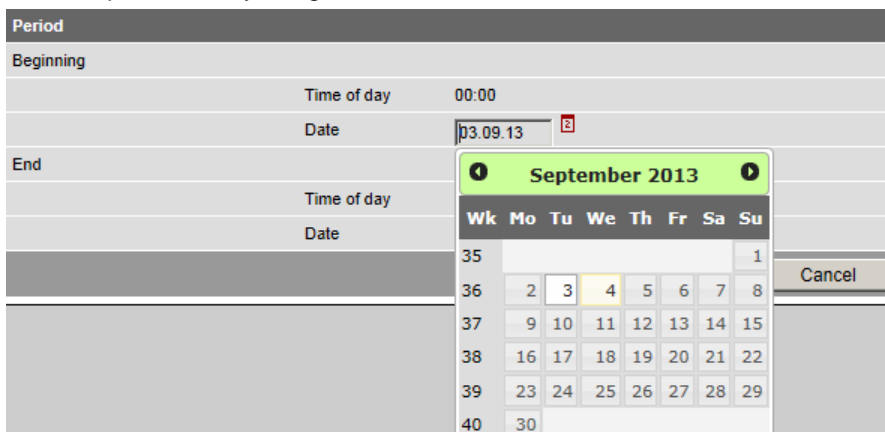

5. Confirm the selected period with **OK**.
6. The **Export** window may be displayed for larger amounts of trend data. The window is skipped for smaller files.

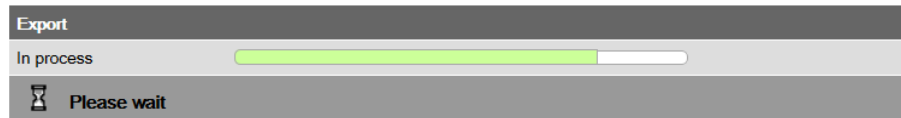

7. In the following window, select either **Open** or **Save**.  
The file name is composed as follows:
  - trend\_data\_x\_ (with x representing trend channel 1...5)
  - Download date (yyyymmdd)
  - Datum des Downloads (yyyymmdd)

### Example using Internet Explorer

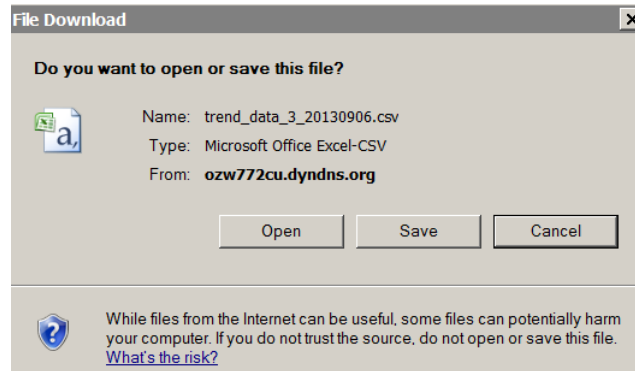

### Example with Firefox

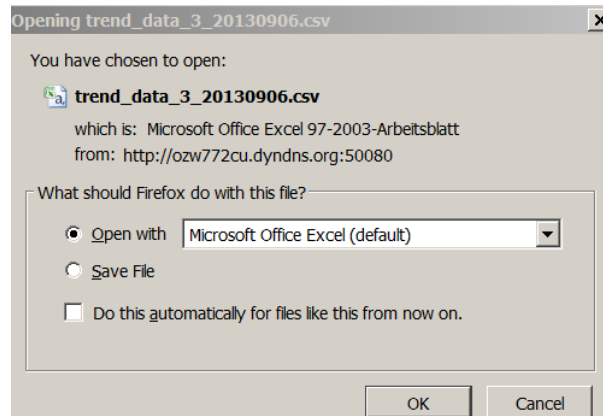



### Note

Files can be exported whether trends are ongoing or stopped.

## 8.5 Import/export trend definitions

Trend definitions can be exported and imported as a file.

The following buttons **Export**  and **Import**  are available to this end. The export is individual for each trend channel.

### Note

Export/Import includes only the trend definitions. The logged trend data is neither exported nor imported.

### Export trend definition

1. Under primary navigation, select **File transfer** menu (see Section 8.1 "Overview").
2. On the desired trend channel, click **Export**  symbol.
3. In the following window, select **Save**. The views differs by browser.  
The file name is formed as follows:
  - trendx.trx (with x representing trend channel 1...5).

## Example with Internet Explorer

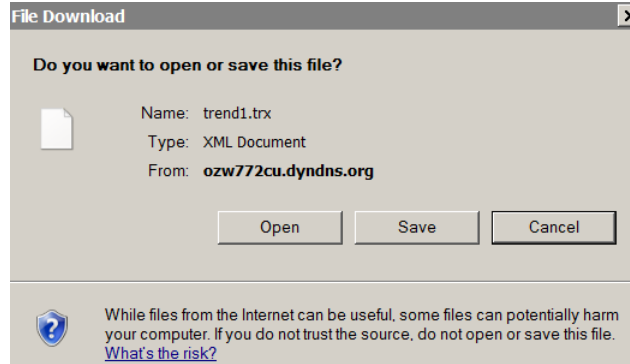

## Example with Firefox

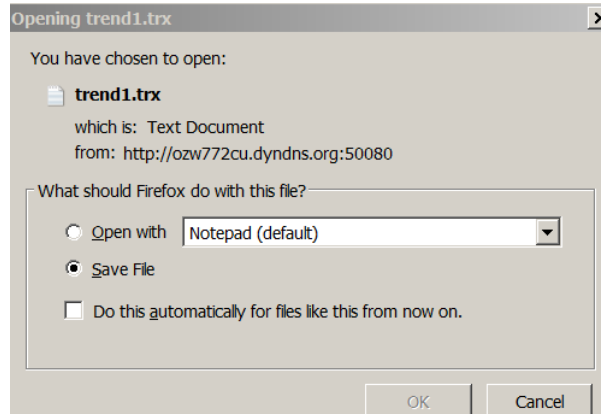

## Note

The trend definition can be exported during trending.  
On compatibility with ACS, see Section 8.6.1 "ACS offline trend compatibility".

## Import trend definition

1. Under primary navigation, select **File transfer** menu (see Section 8.1 "Overview").
2. For the desired trend channel, click **Import** .  
A request is displayed to delete existing trend data if the trend channel was previously used.



3. Confirm with **OK**.
4. In the following window, **Browse** to select the file with the desired trend definition.



5. Click **Open** to confirm.
6. The name of the selected file is displayed.

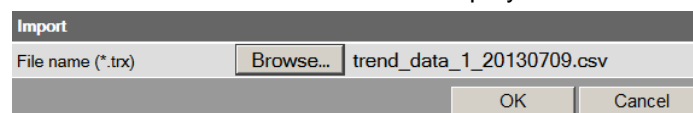

7. Click **OK** to confirm.
8. The data point address must be changed in the following window if the device of the trend definition for import does not match with the device on the plant; true even if the data point matches (the data point address is specific to the device).

9. Select checkbox.

10. Select the desired data point address from the drop-down list.

11. Confirm with **OK**

In the display example, the address 0.2.230 is retained since it is an import within the same device.

12. You can check the settings for import in the following window and change as needed.

The field turns orange if the selected data point address is unavailable. The data point address must be corrected to a valid value prior to confirmation.

13. Click **OK** to confirm.

14. The Save window opens with another warning that the previous trend data of the trend channel is deleted.

15. Click **OK** to confirm the action.

Trend data is imported and the trend goes to the defined state as per the imported file:

- A trend exported in the state "Running" is started automatically after the import is completed, as long as bus load does not exceed 100%.
- A trend exported in state "Completed", is not started after import.

**Note**

Only trend definitions of version V2.0 can be imported.

**Copy trend definition within OZW**

A trend definition can be copied as follows within the same OZW:

1. Export trend definition for the desired trend channel.
2. Import trend definition to another trend channel.



## 8.6 ACS Trend











### 8.6.1 ACS offline trend compatibility

#### ACS V9.00 or older

Offline trend definitions from ACS V9.00 or older can still be written to OZW, run there and read.

Trends are listed on the OZW trend overview page, but cannot be exported or edited there. They are displayed in gray on the overview page and the buttons are hidden.

A struck out pencil symbol indicates that this trend cannot be edited in OZW. These trends may only be operated via ACS.

Name	Status	Abfrage Intervall	Rollende Aufzeichnung	Busbelastung	Aktion
Test Trend ACS	Vorgang läuft	?	3 Tage	20 %	
	Ungültig	?	0 Tage	0 %	  
Test 3	Vorgang läuft	1m	145 Tage	2 %	
	Ungültig	?	0 Tage	0 %	  
	Ungültig	?	0 Tage	0 %	  

22 % Aktuelle Busbelastung

The interval cannot be displayed in this case and is displayed with "?".

#### Warning

For ACS V9.00 or older, the web-defined trends cannot be read and are therefore unavailable. ACS writes its trend definitions to the first, as viewed from ACS, available trend channel. As a result, a web-defined trend can be overwritten without warning.

#### ACS as of V9.01

As of ACS V9.01, the ACS and OZW trend definition is compatible. The trends can be defined or edited in ACS or OZW.

#### Note

A trend created in OZW or as of AVS V9.01 cannot be edited or displayed with ACS V9.00 or older versions.

### 8.6.2 ACS trend bus load

#### ACS V9.00 or older

The bus load of an ACS trend is displayed at a fixed value of 20%. This corresponds to the maximum possible load.

A trend written via ACS automatically changes to the status established by the trend definition.

#### ACS as of V9.01

The bus load of an ACS trend is displayed with the current value.

The trend automatically changes to the state established in the trend definition.

#### Note

The trend is only started for a trend definition of "Running" if the resulting overall bus load does not exceed 100%.

## 9 KNX S-Mode

Web Server OZW772.xx supports KNX S-Mode.

This section describes the supported properties for KNX S-Mode.

### S-mode

"S-Mode stands for system mode. This mode primarily is characterized by the assignment of (logical) group addresses to S-mode data points to communicate process values.

### Supported properties

OZW772.01 supports the following functions:

- System time
- Alarm info

The following supplemental functions are integrated as of version OZW772.04/16/250:

- Lighting control
- Blinds control
- Temperatures from third-party products
- Energy values
- Scene control

This permit central control of heating, ventilation, air conditioning, and electrical installations.

Data points recording by OZW can be used, for example, for trending, to depict the plant diagram or to calculate thermal or electrical energy consumption.

Example for showing KNX data points in a plant diagram:

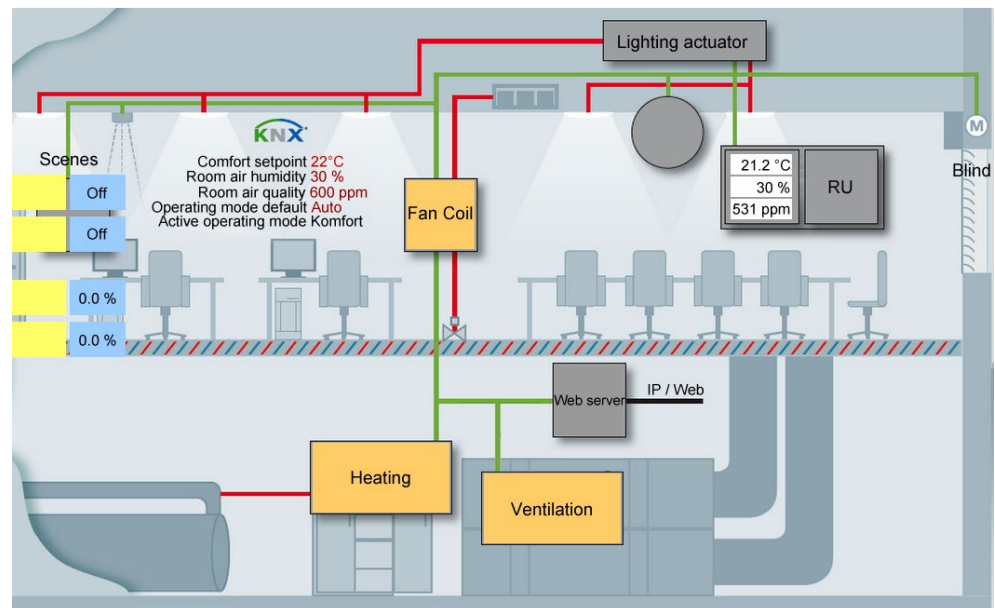

**KNX interfaces**

The web server OZW772.xx also assumes the KNX USB and KNX interface (KNXnet/IP) using its built-in USB and Ethernet interfaces. Separate devices to connect the ETS to the KNX bus or via USB and Ethernet are no longer necessary.

**Acronyms**

<b>Abbr.</b>	<b>Meaning</b>
DP	Data point
DPT	Data point type.
ETS	Engineering Tool Software.
KNX	Konnex
S-mode	System mode (communication mode in KNX networks).

**Additional information**

Addition information on KNX and Synco devices with S-Mode data points can be found in document CE1Y3110.

## 9.1 Configuration in KNX S-Mode

---

### Configuration/commissioning workflow

After installing the controller and the web server, the plant is commissioned as follows:

- Plant commissioning via ETS (addressing and S-Mode binding)\*
- Controller commissioning with ACS\*
- Web server commissioning via web browser or ACS
- Generate web pages on the web server.

### Important note



\* Both tools include parameters for RDG/RDF controllers, but ETS can only write. Reset is only possible with ACS790. The tool sequence is important to ensure a valid configuration and backup: First ETS and then ACS.

### ETS

The ETS software permits planning and commissioning of KNX installations of all sizes.

ETS is a registered trademark of the KNX Association ([www.knx.org](http://www.knx.org)) and can be purchased and downloaded via its website. Product data for OZW772 is compatible with ETS as of version 4.

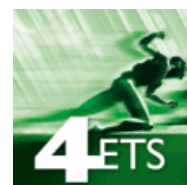

In ETS, the actual building (apartments, rooms), including all KNX devices and wiring structures are mapped virtually. Sensors and actuators are connected as desired.

The finished configuration is saved as a project and loaded to the web server and other participating devices.

### Data points

Sensors and actuators are mapped as data points.

The format and number of bits, bit coding, value range and, where required, the unit (°C, %, m3/h, etc.) are specified in each data point type.

KNX S-Mode data points receive, with ETS, all attributes needed so that only the web page can be generated with the web browser.

### Number of data points

A maximum of the following data points can be used depending on the device type:

- OZW772.01 7 DP
- OZW772.04 237 DP
- OZW772.16 237 DP
- OZW772.250 237 DP

A data point can be used multiple times but then is also counted multiple times.

### Placing data points on the pages

The web server supports 10 KNX S-Mode pages that can be used to place the data points.

Any number of data points can be used per page as long as the maximum number of usable data points is not exceeded.

An update takes up to 70 second for 237 S-Mode data points on the same page. We recommend grouping the data points in a logical manner and spreading them out over various pages.

## Page names

The pages can be given names in ETS with a maximum of 20 characters. As a default, they are numbered with KNX page 1 ... KNX page 10.

Allowable characters for names:

a-z, A-Z, 0-9, space ! " # \$ % & ' ( ) \* , - . / : ; < = > ? @ [ ] \ ^ \_ ` { } | ~  
(ASCII 20-7Fh)

Typical page names include:

- Living room, kitchen, bedroom, kids rooms, etc.
- or
- Lighting, blinds, temperature values, energy values, etc.

## Example

### Page names in ETS4

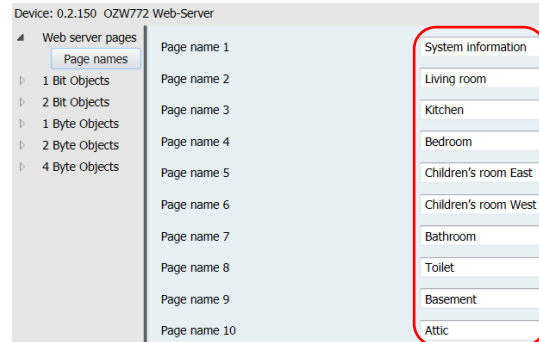

### Page names in OZW772

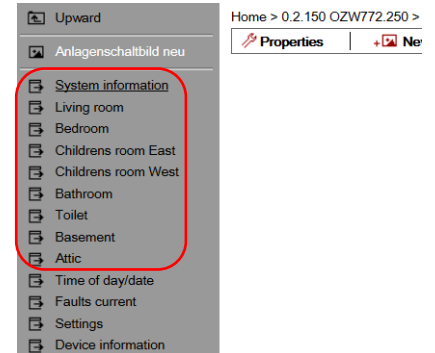

ETS issues an error message if you exceed the maximum entry length of 20 characters.

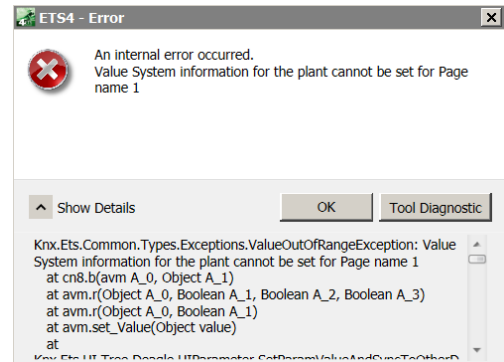

## Data point names

Each data point can be assigned a name in ETS up a maximum of 36 characters. The same characters as for page names are allowed.

Typical data point names include:

- Time
- Ceiling light living room
- Floor light living room
- Blinds 1 living room
- Temperature sensor outside B9
- Temperature sensor boiler B10
- Energy consumption heating

## Example

### Data points in ETS4

The screenshot shows the configuration interface for a data point in ETS4. The device is identified as '0.2.150 OZW772 Web-Server'. The configuration is for a '1 Bit Value Change/Display' data point. The 'Value 1 (Change)' is set to 'Yes', the 'Data point type' is '1.001 Off/On', the 'Data point name 1' is 'Ceiling lights' (highlighted with a red box), and the 'Web server page' is 'Page 2'.

### Data points in OZW772

The screenshot shows a list of data points for the OZW772 device. The 'Ceiling lights' data point is highlighted with a red box. The table below shows the details of the data points.

Data point	Value
Ceiling lights	---
Free-standing luminaire	Off
Dimmer	0.0 %
Living room temperature	--- °C
Room air quality	819.84 ppm
Energy consumption heating	0 kWh
Energy consumption hot water	0 kWh

ETS issues an error message if you exceed the maximum entry length of 36 characters.

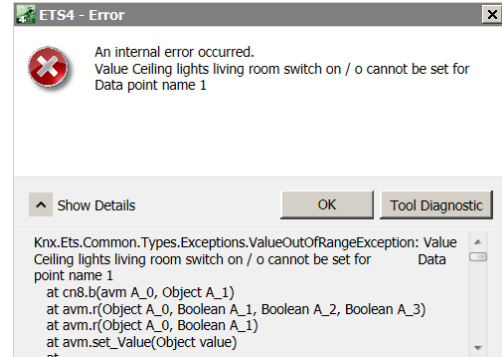

## Data point types and sub-types

An appropriate data point type and sub-type is preselected based on the desired data point function.

### Data point types

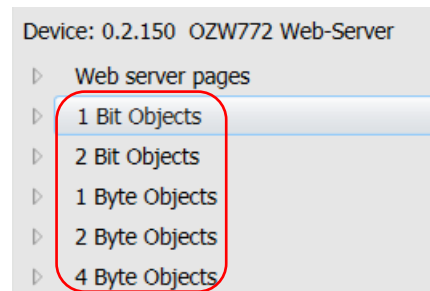

### Data point sub-types

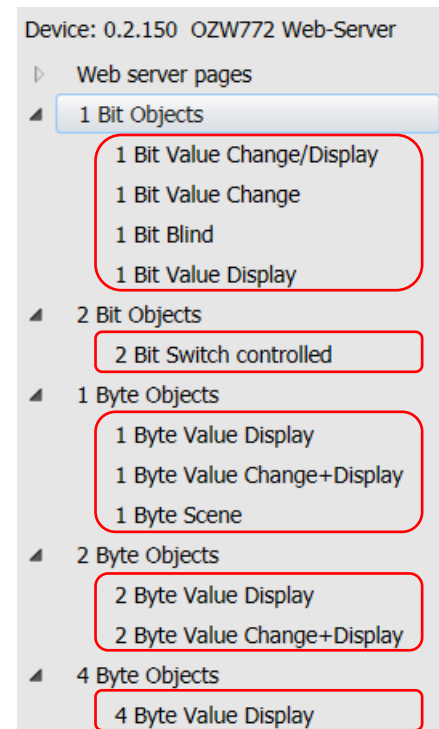

The data point sub-types are available in the following number:

Data point sub-types	No.	Data point numbers
1 bit value edit/display	40	8...47
1 bit value edit	20	48...67
1 bit value blinds	20	68...87
1 bit value display	20	88...107
2-bit switching controlled	5	108...112
1 byte value display	20	113...132
1 byte value edit/display	20	133...152
1 byte scene	5	153...157
2 byte value display	20	158...177
2 byte value edit/display	20	178...197
4 byte value display	40	198...237

A total of 237 data points are available, together with 7 standard data points (data point numbers 1...7).

## ID/Name/Decoding

Each data point sub-type has an ID, a name, and a specific selection of possible settings (decoding).

**Description of data point types**

Below is a listing of all available data point types, data point sub-types, and possible settings.

**System time and faults**

**Data point number 1...7: Standard data points**

Number	Name	Object Function
1	System time	Receive / Transmit
2	Date	Receive / Transmit
3	Time of day	Receive / Transmit
4	Fault information	Transmit
5	Confirm faults	Receive
6	Fault state (normal/faulty)	Transmit
7	Fault transmission (enable/disable)	Receive

Setting for ID/Decoding is defaults on these data points:

Number/name	ID	Decoding
1: System time	19.001	Date / Time
2: Date	11.001	Date
3: Time of day	10.001	Time of day
4: Fault information	219.001	Alarm Info
5: Confirm faults	1.016	Confirm
6: Fault state (normal/faulty)	1.005	Alarm
7: Fault transmission (enable/disable)	1.003	Release

**All following data points**

The following setting options are available on all following data point types:

- A data point is **Enabled/disabled** via the setting option alongside "Value xx"



- A data point is assigned a **page** via the setting option "Web server page"



- A **name** is assigned to a data point in the field "data point name", e.g. instead of the default name "Data point type/one-up number"

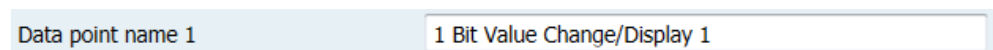

A meaningful name such as

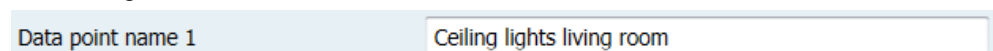



## 1 bit data points

### Data point numbers 8...47: Change/display value 1...40"

8	1 Bit Value Change/Display 1	Transmit
9	1 Bit Value Change/Display 2	Receive

Uneven values are used for "edit"; even for "display".

Value 1 (Change)	Yes
Data point type	1.001 Off/On
Data point name 1	1 Bit Value Change/Display 1
Web server page	Page 1
Value 2 (Display)	Yes
Data point type	1.001 Off/On
Data point name 2	1 Bit Value Change/Display 2
Web server page	Page 1

Available settings for the data point type:

- 1.001 Off/On
- 1.003 Disable/Enable
- 1.008 Up/Down
- 1.009 Open/Closed
- 1.018 Unoccupied/Occupied

### Data point numbers 48...67: "Change value 1...20"

48	1 Bit Value Change 1	Transmit
----	----------------------	----------

Value 1 (Change)	Yes
Data point type	1.001 Off/On
Data point name 1	1 Bit Value Change 1
Web server page	Page 1

Available settings for the data point type:

- 1.001 Off/On
- 1.002 False/True
- 1.003 Disable/Enable
- 1.005 No Alarm/Alarm
- 1.006 Low/High
- 1.007 Decrease/Increase
- 1.008 Up/Down
- 1.009 Open/Closed
- 1.010 Stop/Start
- 1.017 Trigger
- 1.018 Unoccupied/Occupied

### Data point numbers 68...87: "Blinds 1...20"

68 1 Bit Blind 1 Transmit

Value 1 (Change)	Yes
Data point type	1.008 Up/Down
Data point name 1	1 Bit Blind 1
Web server page	Page 1

Available settings for the data point type:

1.007 Decrease/Increase  
1.008 Up/Down

### Data point numbers 88...107: "Display value 1...20"

88 1 Bit Value Display 1 Receive

Value 1 (Display)	Yes
Data point type	1.001 Off/On
Data point name 1	1 Bit Value Display 1
Web server page	Page 1

Available settings for the data point type:

1.001 Off/On  
1.002 False/True  
1.003 Disable/Enable  
1.005 No Alarm/Alarm  
1.006 Low/High  
1.009 Open/Closed  
1.011 Inactive/Active  
1.018 Unoccupied/Occupied  
1.019 Closed/Open

## 2 bit data points

### Data point numbers 108...112: "Switching controlled 1...5"

108 2 Bit Switch controlled 1 Transmit

Value 1 (Change)	Yes
Data point type	2.001 Off/On controlled
Data point name 1	2 Bit Switch controlled 1
Web server page	Page 1

Available settings for the data point type:

2.001 Off/On controlled  
2.008 Up/Down controlled

## 1 byte data points

### Data point numbers 113...132: "Display value 1...20"

113	1 Byte Value Display 1	Receive
Value 1 (Display)	Yes	
Data point type	5.001 Percentage (0..100 %)	
Data point name 1	1 Byte Value Display 1	
Web server page	Page 1	

Available settings for the data point type:

- 5.001 Percentage (0..100 %) 
- 5.004 Percentage (0..255 %)
- 5.010 Value (0..255)
- 6.001 Percentage (-128..127 %)
- 6.010 Value (-128..127)
- 20.002 Building Mode
- 20.003 Occupancy Mode
- 20.102 HVAC Mode
- 20.103 DHW Mode
- 20.105 HVAC Control State
- 20.107 Changeover Mode

### Data point numbers 133...152: 1 "Value change+display 1...20"

133	1 Byte Value Change+Display 1	Receive and Transmit
Value 1 (Change+Display)	Yes	
Data point type	5.001 Percentage (0..100 %)	
Data point name 1	1 Byte Value Change+Display 1	
Web server page	Page 1	

Available settings for the data point type:

- 5.001 Percentage (0..100 %) 
- 5.004 Percentage (0..255 %)
- 5.010 Value (0..255)
- 6.001 Percentage (-128..127 %)
- 6.010 Value (-128..127)
- 20.002 Building Mode
- 20.003 Occupancy Mode
- 20.102 HVAC Mode
- 20.103 DHW Mode
- 20.105 HVAC Control State
- 20.107 Changeover Mode

### Data point numbers 153...157: "Scene 1...5"

 153	1 Byte Scene 1	Transmit
Value 1 (Change)	Yes	
Data point type	18.001 Scene Control	
Data point name 1	1 Byte Scene 1	
Web server page	Page 1	
Scene Number	1	

Available settings for the data point type:

**18.001 Scene Control**

The field "Scene number" defines which scene number [1...64] is affected by the command.



- 1
- 2
- 3
- 4
- 5
- 6

### 2 byte data points

### Data point numbers 158...177: "Display value 1...20"

 158	2 Byte Value Display 1	Receive
Value 1 (Display)	Yes	
Data point type	7.001 Value (0..65535)	
Data point name 1	2 Byte Value Display 1	
Web server page	Page 1	

Available settings for the data point type:

**7.001 Value (0..65535)**

- 7.005 Time (s)
- 7.006 Time (min)
- 7.007 Time (h)
- 7.013 Brightness (lux)
- 8.001 Value (-32768..32767)
- 9.001 Temperature (°C)
- 9.002 Temperature difference (K)
- 9.004 Brightness (lux)
- 9.005 Speed (m/s)
- 9.006 Pressure (Pa)
- 9.007 Humidity (%)
- 9.008 Air Quality (ppm)
- 9.022 Power Density (W/m2)
- 9.024 Power (kW)
- 9.025 Volume Flow (l/h)
- 9.027 Temperature (°F)

## Data point numbers 178...197: "Value change+display 1...20"

178 2 Byte Value Change+Display 1 Receive and Transmit

Value 1 (Change+Display)	Yes
Data point type	7.001 Value (0..65535)
Data point name 1	2 Byte Value Change+Display 1
Web server page	Page 1

Available settings for the data point type:

- 7.001 Value (0..65535)
- 7.005 Time (s)
- 7.006 Time (min)
- 7.007 Time (h)
- 7.013 Brightness (lux)
- 8.001 Value (-32768..32767)
- 9.001 Temperature (°C)
- 9.002 Temperature difference (K)
- 9.004 Brightness (lux)
- 9.005 Speed (m/s)
- 9.006 Pressure (Pa)
- 9.007 Humidity (%)
- 9.008 Air Quality (ppm)
- 9.022 Power Density (W/m2)
- 9.024 Power (kW)
- 9.025 Volume Flow (l/h)
- 9.027 Temperature (°F)

## 4 byte data points

## Data point numbers 198...237: "Display value 1...40"

198 4 Byte Value Display 1 Receive

Value 1 (Display)	Yes
Data point type	12.001 Value (unsigned)
Data point name 1	4 Byte Value Display 1
Web server page	Page 1
Metering medium	Heat and cooling energy
Identification number	12345678

Available settings for the data point type:

- 12.001 Value (unsigned)
- 13.001 Value (signed)
- 13.010 Energy (Wh)
- 13.013 Energy (kWh)
- 14.019 Electric Current (A)
- 14.027 Electric Potential (V)
- 14.031 Energy (J)
- 14.036 Heat flow rate (W)
- 14.056 Power (W)
- 14.065 Speed (m/s)
- 14.068 Temperature (°C)
- 14.076 Volume (m3)

For energy meters, the same data type must be used as specified by the producer for display purposes. This is the only way to avoid a loss in accuracy on large

numbers, since large floating point numbers it is rounded off to the next displayable value.

Data points for types 12.xxx, 13.xxx and 14.xxx are labeled with the definition of the counter medium as energy meter. So that the following data is written once a day to the consumption data file. See sections:

- Meter medium.
- Identification number.

Data point value

"Meter medium" defines what is actually measured:

- Other
- Oil
- Electricity
- Gas
- Heat (outlet)
- Steam
- Hot water
- Cold water
- Heat cost allocator
- Compressed air
- Cooling energy (outlet)
- Cooling energy (inlet)
- Heat (inlet)
- Heat and cooling energy
- 

A unique identification number of the meter used (0 - 99999999) is entered under "Identification number".

Identification number	12345678	<input type="button" value="▲"/> <input type="button" value="▼"/>
-----------------------	----------	--

### Communication properties of data points

Data points can have various communication properties. They are defined in KNX as flags. The flags can be unset (0) or set (1).

Flag	Meaning	Description (for set flag = 1)
C	Communications	Communication is possible via the bus.
R	Read	The data point can be read via the bus.
W	Write	The data point can be described via the bus.
T	Transfer	A change in data point is sent via the bus.
U	Refresh	The data point can be updated by other participants.

Flags are preset on participating devices/actuators/sensors. Some examples of typical communication properties:

Device function	Set flags
Displays (state, e.g. room temperature)	C W T U
Send (trigger, e.g. light switch)	C T
Send + display (state + trigger, e.g. heating setpoint).	C R W T U

## Data exchange via group addresses

### Example

Data points must be connected in order to exchange them. This occurs in ETS via the group address pane.

The room unit in the living room transmits its room temperature actual value to the web server OZW so that it is available there for the trend function and display of the plant diagram.

### Procedure

A group is created in the ETS where the two data points are connected to one another. In this case, desirable:

- Main group: **Heating**
- Center group: **Actual values**
- Subgroup: **Living room**

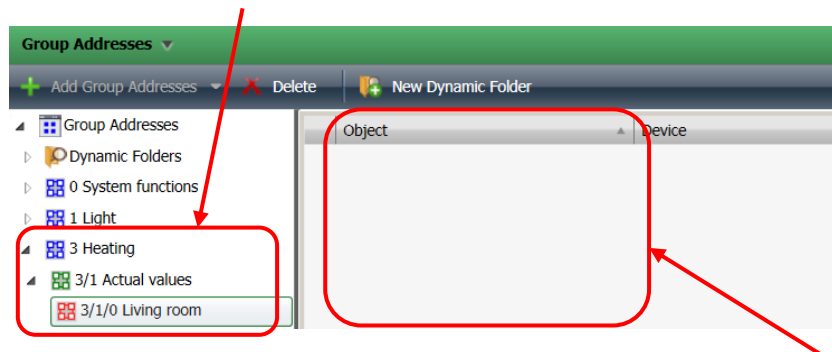

No objects (data points) are displayed in the pane for subgroup "Living room" since no data points have been linked with this group address.

First, select the desired room unit (QMX3.P37) from the device list. Left click data point "1: Room temperature [°C] – Transmit" to drag it to the empty pane.

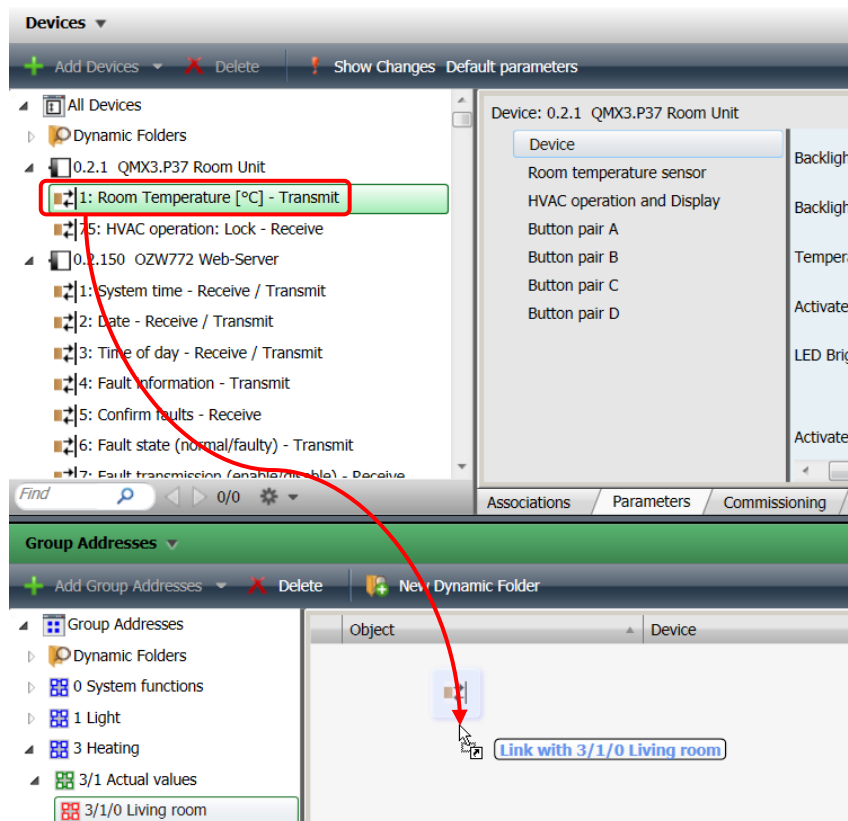

The data point is now linked to the group address "Living room" and added to the list of object.

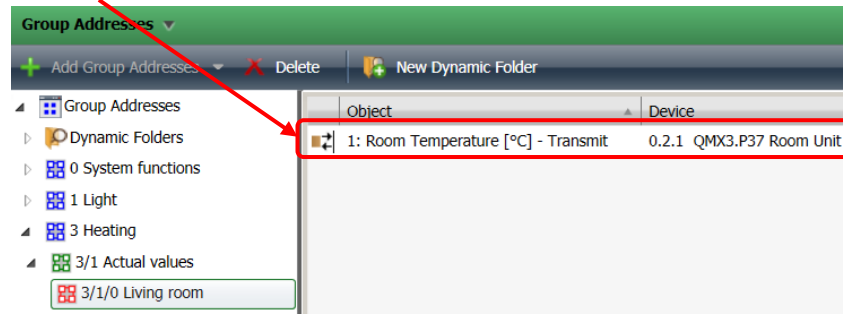

An available 2-byte data point is required to display a temperature in OZW. It is select from the ETS device list under "OZW772 web server" and defined.

Select "9.001 temperature (°C)" as the data point type.

Furthermore, the data point should be names in a meaningful manner and assigned a page on the web server. In this case, page 2, which was defined as the living room when the page name was issued.

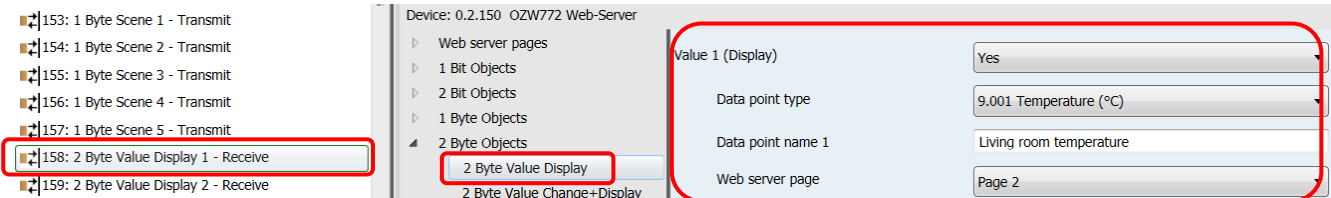

The data point is now dragged to the group address:

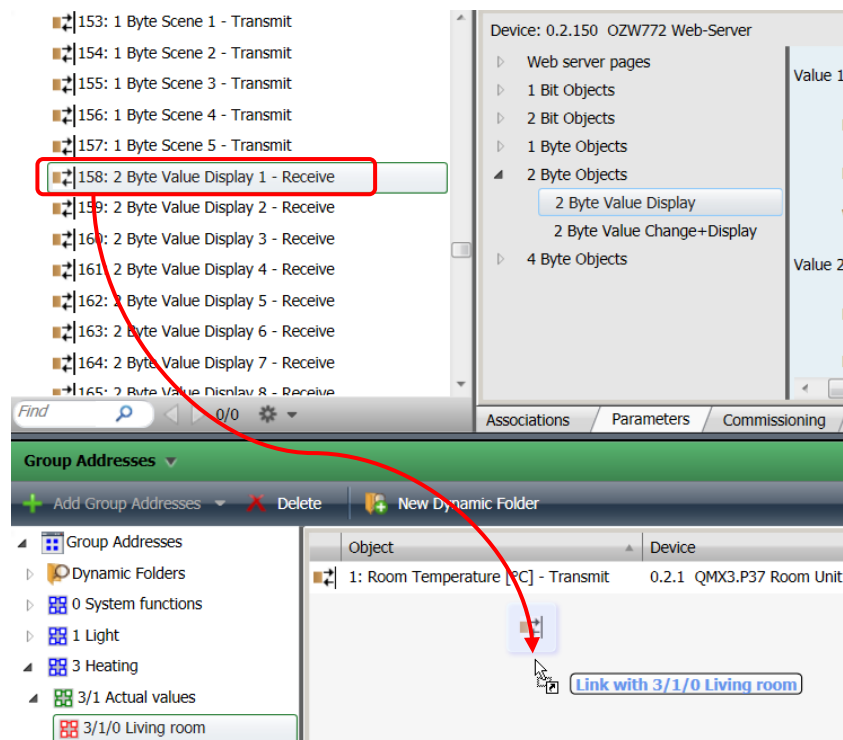



**Result:**

Both data points are now linked to the group address "Living room" and added to the list of object.

The room unit sends its measured temperature which is received by OZW.

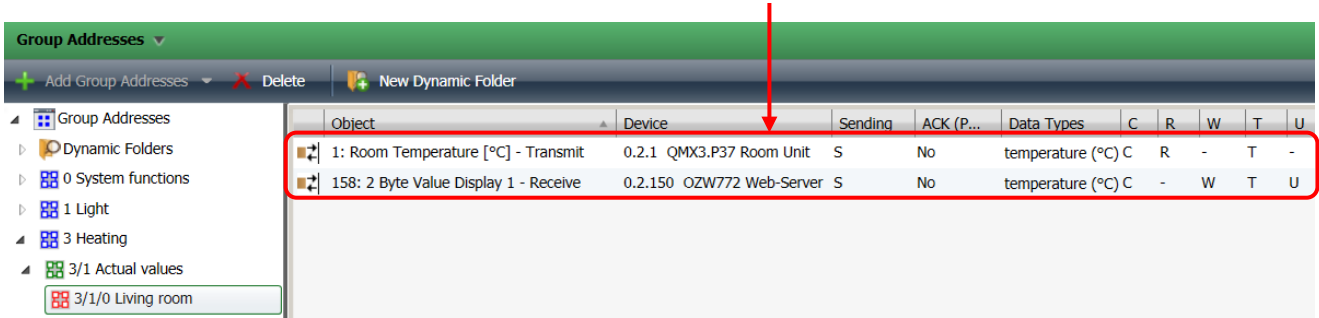

**Transmit project data**

When transmitting the project or portions of the project from ETS to the devices on the bus, all the changes are saved on the applicable devices.

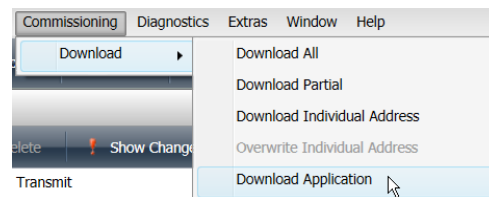

The various possibilities are described in the ETS documentation.

When ETS is connected to the KNX bus via OZW, ETS has the KNX address 15.15.254.

By configuring the OZW with ETS, the default group addresses are overwritten by system time and faults.

## Update transmitted project data in OZW.

The device stats of changed devices is no longer up-to-date after transmitted project data from ETS to the OZW.

OZW must be selected and updated with "Generate". Administrator or service user rights are required.

	Device name	Device address	Device type	Serial no	State	Generated on
<input type="checkbox"/>	OZW772.250	0.2.150	OZW772.250	00FD00FF2A11	Not updated	09.04.2014 15:38
<input type="checkbox"/>	QAX913	0.2.200	QAX913-9	00FD000BD0D1	Generated	03.04.2014 15:23

Add Delete **Generate** Hide

Device web pages

Process running: Device 1 from 1

Process takes a few minutes

Confirm with "OK".

Device web pages

Process finished

OZW is now updated.

	Device name	Device address	Device type	Serial no	State	Generated on
<input type="checkbox"/>	OZW772.250	0.2.150	OZW772.250	00FD00FF2A11	Generated	14.05.2014 14:37
<input type="checkbox"/>	QAX913	0.2.200	QAX913-9	00FD000BD0D1	Generated	03.04.2014 15:23

Add Delete Generate Hide

The changes can now be viewed in the menu tree.

The following changes are recognized and displayed on the device list as "Not updated":

- Writing and entire project
- Write a project without changes
- Add / delete /rename KNX pages.
- Add /Delete /Change type/Rename data points.

## 9.2 Operation KNX S-mode

### Privileges

All KNX pages and S-Mode data points are access as of end-user level.

### Page display in OZW772

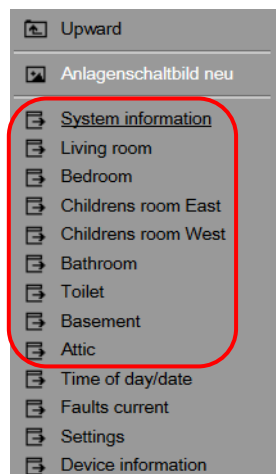

Home > 0.2.150 OZW772.250 >  
 Properties | + Ne

The pages defined via ETS are displayed in OZW772 in the secondary navigation between "New plant diagram" and "Time/date".

Only defined pages are displayed. For example, only 5 entries are located in secondary navigation is only 5 pages were defined.

ETS takes over page names and they cannot be changed in OZW. Changing the user language on OZW does not affect these texts.

### Data point display

All data points defined to in ETS and assigned as page are displayed in OZW. The following example has all data points for page "Living room":

Datapoint	Value
Ceiling lights	---
Free-standing luminaire	Off
Dimmer	0.0 %
Living room temperature	--- °C
Room air quality	819.84 ppm
Energy consumption heating	0 kWh
Energy consumption hot water	0 kWh

ETS takes over data point names and they cannot be changed in OZW. Changing the user language on OZW does not affect these texts.

The data points are listed in the sequence of data point main types and within this list, in the engineering sequence.

### Enter values

A pencil is displayed after the value on data points that can be edited. Click the symbol to show the associated operating dialog.

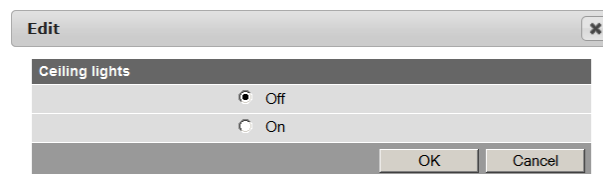

The value is sent over the bus to the defined S-Mode address by clicking the value and confirming it with "OK", even if the value has not changed. "Cancel" cancels the operating dialog and not value is sent over the bus.

The dialog depends on the type of data point. Here is an example for air quality:

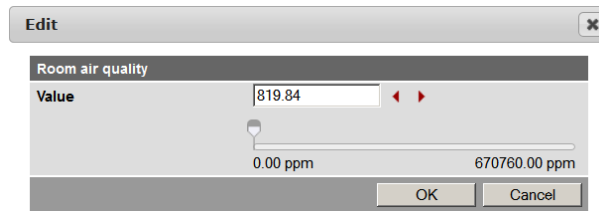

## Dynamic display

The value is displayed as is the pencil depending on the type of data point.

Display examples	Data point type
---	Send
0.0 %	Displays
819.84 ppm	Send and display

- The value for the send data points is displayed as "- - -". The setting values are accessed by opening the operating dialog via the pencil symbol, as illustrated in the example for "ceiling lighting". The value is sent, but the displayed remains fixed on "- - -".
- Only the present data point value is displayed on display data points (i.e. no pencil symbol).
- For send and display data points, both the present value as well as the pencil symbol are displayed.

"- - -" is also displayed if the value for the displayed data point has not yet been read.

## Plant diagram, trending, and access via web services

As soon as a transmitted ETS project is updated with "Generate" on OZW, the S-Mode data points are available for customized plant diagrams, trending, and access via web services (Web API).

Some data points are not available for trending and are hidden automatically when selecting the trend definition.

## Behavior at restart

After a restart of OZW, a query is made for each display data point as soon as the web server accesses it the first time. OZW sends a second query if it does not get a response to the first one. The value is displayed as "- - -" as long as not response is received.

OZW772 does not detect as loss of KNX bus power and a subsequence restart to KNX communications. In other words, the old display value remains until the next change of value.

## COV

Each change of value (COV, Change Of Value) to a send data point (or send/display data point) is sent over the bus. Regardless of whether the change is local on the OZW or was made via the web interface. The value is sent as soon as the setting is confirmed with "OK", even if the actual value was not adjusted.

## Heartbeat.

Communication on and over the KNX bus is event-controlled. The data points have no heart beat as a rule.

## Default KNX subtype

Data points can be defined in ETS that are not explicitly supported by OZW. OZW converts any such data points received from ETS into its default subtypes.

<b>KNX main type</b>	<b>Default KNX subtype</b>	<b>Name and decoding</b>
1.*	1.001	Switching (Off/On)
2.*	2.001	Prio. switching (Off/On controlled)
5.*	5.001	Percent (0...100%)
6.*	6.001	Percent (-128...127%)
7.*	7.001	Value (0...65535)
8.*	8.001	Value (-32768...32767)
9.*	9.001	Temperature (-273...670 760 °C)
12.*	12.001	Value (unsigned 0...4 294 967 295)
13.*	13.001	Value (signed -2 147 483 648...2 147 483 647)
14.*	14.019	Current (A).
18.*	18.001	Scene control (Scene control: Call up/memorize scene number)
20.*	20.002	Building mode (building operating mode: Building used, building not used, building protection)

\* = unsupported subtype from this main type group

# 10 Appendix

## 10.1 General notes

### Text entry

Names of data points and message text, e.g. of faults, cannot contain special characters or umlauts. Valid characters:

- a...z and A...Z
- 0...9
- ! „ \$ % & , ( ) \* + ` - . / : ; < = > ? "Space

### Note

 When sent, **invalid characters** will be converted to "?" (question marks).

## 10.2 Diagnostics

### 10.2.1 Web server fault codes

### Fault codes

Fault code	Web server fault	Type of fault
<b>General</b>		
0	No fault	No acknowledgement
1	Plant ok	No acknowledgement
2	Fault	No acknowledgement
3	No urgent fault	No acknowledgement
<b>Communications</b>		
5000	No bus power supply	No acknowledgement
5001	System time failure (Web server as slave)	No acknowledgement
5002	>1 clock time master	With acknowledgement
5003	Invalid time of day (Web server time not or incorrectly entered)	No acknowledgement
5012	Device failure (Bus) *	No acknowledgement
5023	Message receiver 1 not reached	No acknowledgement
5024	Message receiver 2 not reached	No acknowledgement
5025	Message receiver 3 not reached	No acknowledgement
5026	Message receiver 4 not reached	No acknowledgement
<b>System configuration errors</b>		
6001	>1 identical device address (Devices have same address)	With acknowledgement

\* Device failure (bus) is a fault generated by the web server for a failed device. As result, the device failure (bus) is assigned to "System faults", where as all other faults generated by the web server are assigned as "Local faults".

## 10.2.2 Windows Commander

### Windows Commander

You can use the Windows Commander to check availability of IP addresses, domains or servers:

1. Open Windows commander: *Start > Run*.
2. Enter "cmd".

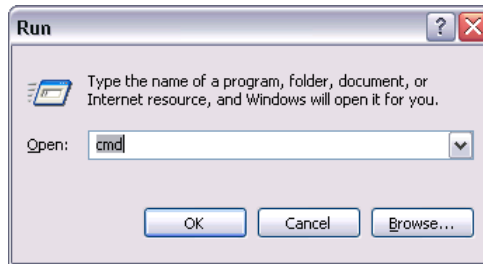

3. Click [ OK ]
4. Enter the desired command in the command line C:\>:

Command	Result, application
ping <IP address> or <domain>	Response times to the query: Checks whether an IP address can be reached in the network.
Tracert <IP address> or <domain>	Progress of the IP address implementation to the goal: Check whether DNS and mail servers can be reached.
nslookup <IP address> or <domain>	Translates an IP address to the domain name and vice versa: Look up domain names.

## 10.3 Communications

### 10.3.1 Internet protocol

---

#### Private networks

The following IP addresses are reserved for private networks:

- Class A: 10.0.0.0–10.255.255.255.
- Class B: 172.16.0.0–172.31.255.255.
- Class C: 192.168.0.0–192.168.255.255 (typical for home networks).

#### Ports

There are predefined public ports and ranges for private ports:

Web browser	http (recommended only on private network)	80
	https (recommended on public network)	443
ACS Tool	ACS Tool	50005
	Offline Trend and FTP	21
ETS Tool	ETS Tool	3671

### 10.3.2 Free e-mail account providers

---

You can use free-of-charge e-mail accounts to send e-mails. Note that some ISPs work with encryption or can be accessed and used only via the web server's DSL connection.

Note



The following list is not conclusive, ISPs are subject to change.

Free e-mail account providers	Address mail server	Port mail server	Authentication	Restriction
<a href="#">Google Mail</a>	smtp.gmail.com	587	Yes	TLS required
<a href="#">Hotmail</a>	smtp.live.com	587	Yes	TLS required
<a href="#">Yahoo! Mail</a>	smtp.mail.yahoo.com	25, 587	Yes	

Additional information on free e-mail providers:

- [http://www.patshaping.de/hilfen\\_ta/pop3\\_smtp.htm](http://www.patshaping.de/hilfen_ta/pop3_smtp.htm)
- <http://www.iopus.com/guides/bestpopsntp.htm>



### 10.3.3 Install RNDIS driver

#### RNDIS driver

The PC requires a USB RNDIS driver for the connection between the PC and the web server. Windows hardware recognition recognizes the web server when the USB cable is plugged into the USB cable. You can start the Add Hardware Wizard if no RNDIS driver is installed.

The driver is installed in the background with an Internet connection as long as the online update service is enabled by the network administrator. You can install the driver manually without an Internet connection.

#### Note



The operating system must be equipped with the latest updates.

#### Automatic installation

Procedure:

1.  Select "Search for and install the hardware automatically (Recommended)".



2. Click [ Next > ]  
The software is installed.

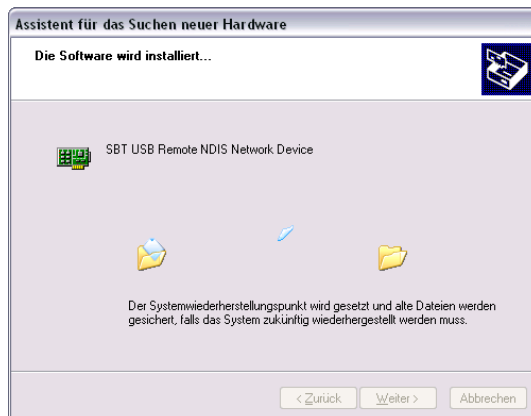

German screenshot [ Weiter ]

Continued on next page.

3. Confirm hardware installation:  
Click [ Continue installation ]

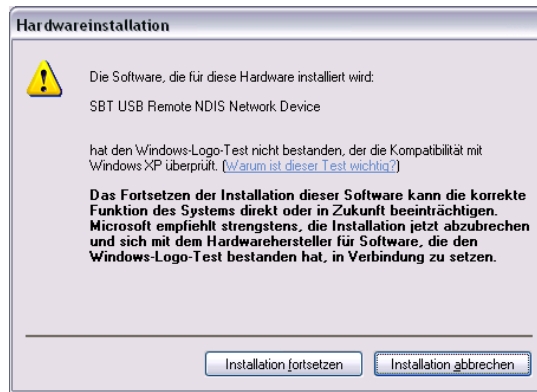

German screenshot [ Installation fortsetzen ]

4. Wait until installation is complete and click [ Finish ]



Result

The RNDIS driver is now installed. The PC can communicate with the web server via USB.

## Manual installation

Procedure:

1.  Select "Install the hardware that I manually select from a list (Advanced)".

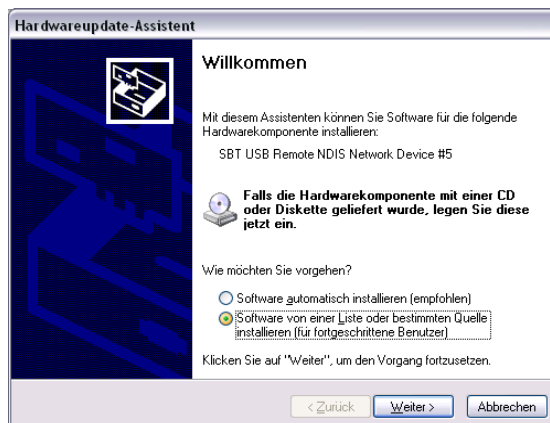

Continued on next page.

2. Enter the source to install the driver.

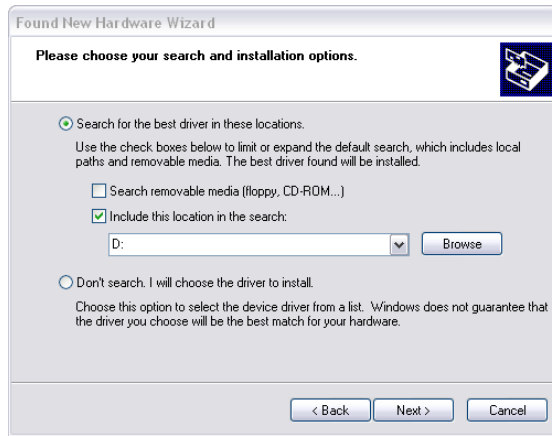

- 3. Click [ Next > ]
- 4. Select the folder with the RNDIS driver.
- 5. Click [ OK ]
- 6. Confirm hardware installation:  
Click [ Continue installation ]

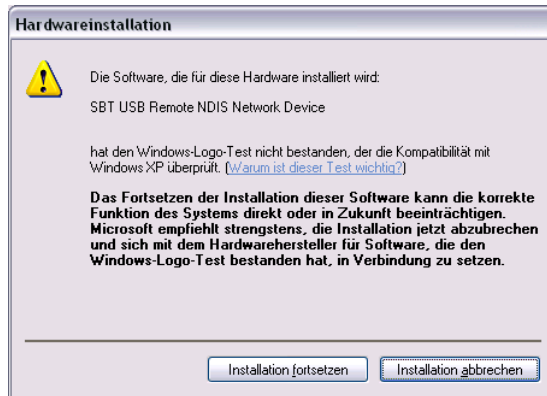

German screenshot [ Installation fortsetzen ]

7. Wait until installation is complete and click [ Finish ]

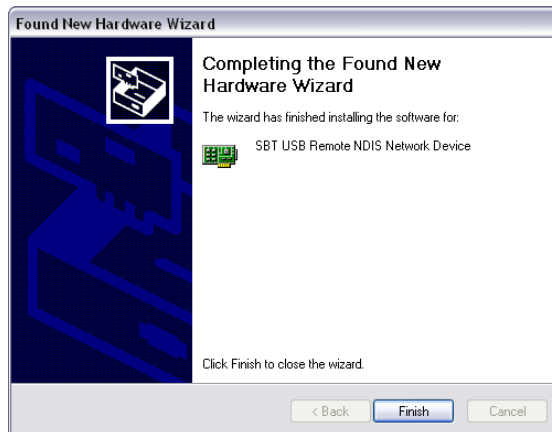

Result

The RNDIS driver is now installed. The PC can communicate with the web server via USB.



- The RNDIS driver is supplied on the web server at <http://<IP address>/drivers/> You can copy the file "SBT\_RNDIS.zip" to your PC via the Ethernet connection (see Section 2.6.1) and unzip it.

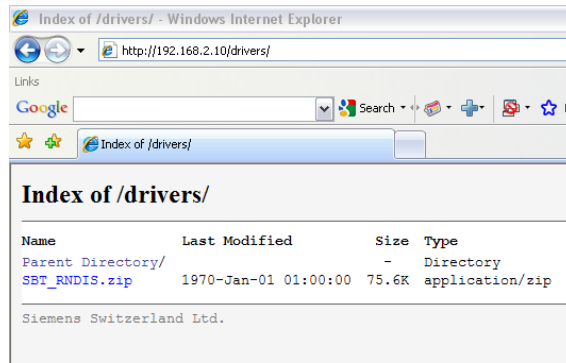

- The RNDIS driver is installed as part of the ACS790 Siemens software installation.

### 10.3.4 Alternative network configuration

#### Alternative configuration

We recommend setting up IP settings for commissioning as an alternative configuration if a PC, connected to a network, is temporarily used to commission the web server and the local area network.

On the PC, set as follows:

1. Select *Start > Control Panel > Network connections > Local Area Connection.*
2. Select the "General" tab.

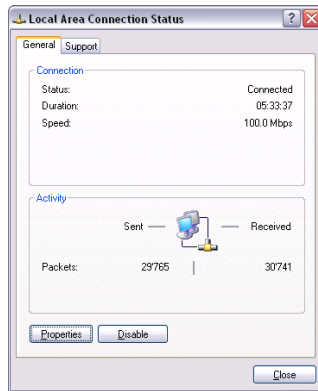

3. Click [ Properties ]
4. Select "Internet Protocol (TCP/IP)".

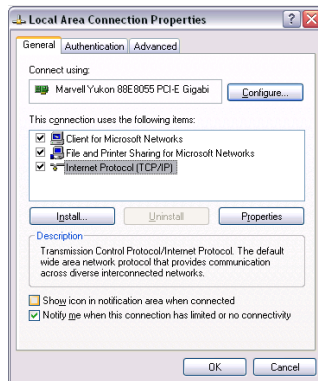

Continued on next page.

5. Click [ Properties ]
6. Select "Alternate Configuration" tab.
7. Enter IP address, subnet mark and operational standard gateway as well as DNS server.

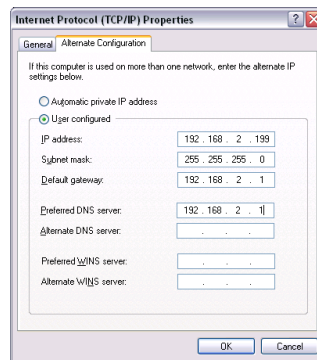

Result

The PC assumes the configuration with these settings as soon as it is no longer integrated in the standard network.

## 10.4 Glossary of Ethernet and Internet terms

---

<b>ADSL</b>	<p>Upstream and downstream channel transport data at different rates, i.e. asymmetrically via a two-wire line (DLS, copper phone line) on a broadband network.</p> <p>Very little data is sent upstream, i.e. to the server, when surfing. The requested data, however, are sent at high speed downstream to the requesting computer. You can call or e.g. send faxes while transmitting data.</p> <p>The Internet Service Provider ISP provides the ADSL connection. You need a DSL modem for this type of connection.</p>
<b>Asymmetrical Digital Subscriber Line</b>	<p><i>see ADSL.</i></p>
<b>Bit rate</b>	<p>The bit rate describes the transmission speed or rate in bits per second (bps).</p>
<b>Broadcast</b>	<p>Data sent out to all participants on the network.</p>
<b>Client</b>	<p>A client is a network device unable to execute certain services and thus requests those services from the server. The server provides the service and sends a reply.</p>
<b>Default gateway</b>	<p>Gateway that is selected when one IP address is outside its own subnet and therefore the standard gateway is unknown.</p>
<b>DHCP</b>	<p>The new Dynamic Host Configuration Protocol allows for dynamic allocation of a network configuration to clients (PC, web server) via a server (router).</p>
<b>Digital Subscriber Line</b>	<p><i>see DSL.</i></p>
<b>DNS</b>	<p>The DNS allows for assigning IP addresses to names (that are easier to remember than 32-bit IP addresses). A DNS server must manage this information for each LAN with Internet connection. When you select an Internet page, the web browser accesses the IP address for that site assigned by the DNS server to open a connection.</p> <p>On the Internet, domain names are assigned to IP addresses as per a hierarchical system. A local PC only knows the address of the local DNS server. This server, in turn, knows the addresses of all PCs on the local network as well as that of the higher DNS servers that, in turn, know the addresses of the next higher DNS servers.</p>
<b>Domain Name System</b>	<p><i>see DNS</i></p>
<b>Domain name</b>	<p>The domain name is the web server designation on the Internet. The DNS server assigns an IP address to the domain name.</p>

<b>DSL</b>	DSL is a type of data transmission allowing for 1.5 Mbps access to the Internet on standard copper phone lines. The Internet Service Provider ISP provides the DSL connection. You need a DSL modem for this type of connection.
<b>DSL router</b>	The DSL router has several functions. It connects the Ethernet network (LAN) and the internal network devices to the Internet. The router then requests the IP addresses for the internal network devices from the DNS server. Port forwarding (NAT, PAT) is also configured in the router. In addition, service "DynDNS", which automatically is updated after a change of the DynDNS server, is activated in the router.
<b>Dynamic DNS</b>	<i>see DynDNS.</i>
<b>Dynamic Host Configuration Protocol</b>	<i>see DHCP.</i>
<b>Dynamic IP address</b>	<p>A dynamic IP address is assigned automatically via DHCP to a network device. As a result, the IP address for a network device differs every time the device logs in or at periodic intervals.</p> <p>The ISP assigns dynamic IP addresses to network devices that are not online continuously, i.e. integrated in the network. Dynamic IP addresses are reassigned to other devices, as the number of addresses is limited. Web server (permanently online) does not use a dynamic IP address.</p>
<b>DynDNS</b>	<p>The DNS server assigns domain names and IP addresses. Dynamic DNS (DynDNS) is needed for dynamic IP addressing. It allows deployment of a network device with dynamic IP address on the Internet.</p> <p>DynDNS ensures that a service is always available on the Internet under the same domain name regardless of the current IP address.</p> <p>A domain name can be registered with a DynDNS service.</p>
<b>Ethernet</b>	Ethernet is a network technology for local networks (LAN). Ethernet operates at a transmission rate of 10 or 100 Mbps and has a maximum range of 100 meters between two network components.
<b>Firewall</b>	A firewall protects networks against unauthorized access from the outside. Firewalls are hardware and/or software measures designed to control data exchange between the private network to be protected and an unsecured network (e.g. the Internet).
<b>Gateway</b>	A gateway is a device connecting networks of different architecture (addressing, protocols, interfaces, etc.). Although not entirely correct, the term often is used interchangeably with router.
<b>HTTP proxy</b>	A proxy is a server used by network devices for Internet traffic. All requests are sent via the proxy server.
<b>HTTPS</b>	The web server supports HTTPS (Hyper Text Transfer Protocol Secure).
<b>Hub</b>	A hub in a star-topology network connects various network devices by receiving all data from one device and forwarding it to other devices.

<b>Hyper Text Transfer Protocol Secure</b>	<i>see HTTPS.</i>
<b>Internet</b>	<p>The Internet is a data network with millions of members. A number of protocols are used to exchange data, summarized under the term TCP/IP.</p> <p>All devices connected to the Internet can be identified via IP address. The DNS server assigns domain names to IP addresses.</p>
<b>Internet Protocol</b>	<i>see IP.</i>
<b>Internet Service Provider</b>	<i>see ISP.</i>
<b>IP</b>	<p>The IP protocol is a TCP/IP protocol. It is responsible for addressing devices on a network based on IP addresses and transmitting data packages from sender to Receiver. The IP protocol determines the order and network connection used to send data packages (routing).</p> <p>The transmission control protocol TCP reassembles the data packages in the right order at the Receiver.</p>
<b>IP address</b>	<p>The IP address is a unique address of a network device on the network based on TCP/IP protocols. The IP address consists of four sections, separated by a dot (<a href="#">192.168.1.1</a>).</p> <p>The IP address comprises the <b>network number and the computer number</b> (number of the network device). Depending on the subnet mask, one, two or three portions form the network or computer number.</p> <p>IP addresses can be assigned automatically or manually. On the Internet, domain names are used rather than IP addresses. The DNS server assigns domain names to IP addresses.</p>
<b>IP address pool</b>	IP address pool defined at the router (IP address range) the DHCP server can be used to assign dynamic IP addresses.
<b>LAN</b>	A local network (size: large building, building sites) is a number of interconnected network devices. In LANs, data is exchanged and resources are used jointly. A LAN can be connected to other networks such as WAN or Internet.
<b>Local Area Network</b>	<i>see LAN.</i>
<b>MAC address</b>	The MAC address allows for worldwide identification of a network adapter (network card). It consist of hexadecimal numbers, grouped in six portions at 2x4 bit each, thus 48 bit, e.g. 00-55-96-5D-00-2C. The MAC address is assigned by the network adapter manufacturer and cannot be changed.
<b>Mbps</b>	Million bits per second indicates the transmission rate in a network.
<b>Media Access Control</b>	<i>see MAC address.</i>



<b>NAT</b>	<p>NAT is a method to translate IP addresses (private IP addresses) in a network into one or several public IP addresses on the Internet. NAT allows us to use several network devices in a LAN together with a public IP address of a router for Internet access.</p> <p>The network devices of the local network are masked by the IP address (router) registered on the Internet. Thanks to this security function, NAT often is used as a part of a network's firewall. Web server is accessible from a public network thanks to the correct NAT table definition; see also port forwarding.</p>
<b>Network</b>	A network (LAN, WAN) is a linked group of devices connected via various lines or radio sharing common resources such as data or peripheral devices.
<b>Network adapter</b>	Hardware to connect network components to a local area network (LAN). Connection can be wired or wireless.
<b>Network Address Translation</b>	See <i>NAT</i> .
<b>Network configuration</b>	All settings an IP-based device requires to work on a network: IP address, subnet mask, standard gateway, preferred DNS server, and alternate DNS server.
<b>PAT</b>	PAT or NPAT (Network and Port Address Translation) translates all private network addresses into one public (dynamic) IP address. In this process, port numbers are exchanged in addition to addresses when there is a connection. As a result, an entire private network only requires one single registered public IP address.
<b>Plant room</b>	The ISP provides the connection to the Internet via DSL or cable TV (at a fee).
<b>Point-to-Point Protocol</b>	See <i>PPP</i> .
<b>Port</b>	<p>Ports are used to exchange data between different applications on a network. The port number addresses the application within a network device. The combination of IP address and port number serves as a unique identification of the Receiver or the sender of the data package with the network.</p> <p>Internet service applications work with set port numbers (HTTP 80, FTP 21). See <a href="http://www.iana.org/assignments/port-numbers">http://www.iana.org/assignments/port-numbers</a> for registered port numbers. Port numbers 0 to 49151 are set and reserved, port numbers 49152 to 65535 are dynamic (and therefore available).</p>
<b>Port and Address Translation</b>	See <i>PAT</i> .
<b>Port Forwarding</b>	<p>With port forwarding, the router forwards data packages from the Internet, destined for a particular port, to the port of the responsible network device. As a result, servers (web server) integrated in a LAN, can be reached from the Internet (without a need for a public IP address). Port Forwarding is achieved by the correct NAT / PAT definition in the router.</p>
<b>PPP</b>	Protocol for dial-up connection of a computer to the ISP.
<b>PPP over Ethernet</b>	See <i>PPPoE</i> .

<b>PPPoE</b>	Protocol used to connect to the Internet via ADSL or DSL.
<b>Private IP address</b>	<p>The private IP address (local IP address) is the address of a network device on a local network (LAN). The provider assigns this address at will. DSL routers have a public IP address for the WAN and a private IP address for the LAN. The following IP ranges are recommended for private IP addresses:</p> <p>10.0.0.0...10.255.255.255 → Class A.  172.16.0.0...172.31.255.255 → Class B.  192.168.0.0...192.168.255.255 → Class C.</p> <p>The first IP address xxx.xxx.xxx.0 and the last IP address xxx.xxx.xxx.255 in a network segment cannot be used, as xxx.xxx.xxx.0 is reserved for the network and xxx.xxx.xxx.255 for broadcasting.</p>
<b>Protocol</b>	A protocol describes the type of communication on a network. It contains rules on opening, managing, and closing a connection, on data formats, time sequences, and possible error correction. Different protocols are needed to allow two applications at different levels to communicate with each other, e.g. TCP/IP protocols on the Internet.
<b>Provider</b>	Provider of telecommunications services. Also referred to as network provider or network operator.
<b>Public IP address</b>	<p>The public IP address is the worldwide valid (global) address of a network device on the Internet. The ISP assigns these addresses. A network device with public IP address is a device establishing a connection between local network LAN and the Internet.</p> <p>DSL routers have a private IP address for the LAN and a public IP address for the WAN (Internet).</p>
<b>Router</b>	A router forwards data packages from a local network LAN to a higher network while selecting the fastest route. A router allows for connecting different networks with different network topologies. For example, the router connects a local network to the Internet.
<b>Secure Sockets Layer</b>	See <i>SSL</i> .
<b>Server</b>	A server accepts requests from clients, processes them and responds to the clients. Network servers, data servers, web servers also assume services for other network devices.
<b>Simple Mail Transfer Protocol</b>	See <i>SMTP</i> .
<b>SMTP</b>	The SMTP protocol is a TCP/IP protocol. It controls e-mail traffic on the Internet. The ISP provides the SMTP server (mail server).
<b>SSL</b>	Outdated form for TLS; see TLS.
<b>Standard gateway</b>	A default gateway (see Default Gateway as well as DSL router) is also referred to as a network address used by clients to send their packages if the target address is outside the immediate network.

<b>Static IP address</b>	Network devices, and servers in particular, integrated permanently in a network, have static IP addresses. Clients often have a dynamic IP address. Web server (integrated permanently in a network) has a static IP address and can thus be reached easily by clients.
<b>Subnet</b>	A subnet subdivides a network into smaller network segments.
<b>Subnet mask</b>	<p>A subnet mask masks the IP address, i.e. it determines which parts of the IP address form the network number and which parts the computer number (e.g. server).</p> <p>Subnet mask 255.255.255.0 means that the first three sections of the IP address determine the network number, and the fourth section is used for the computer number. In this case, the first three IP address sections are identical for all network devices. Example:</p> <p>Subnet mask 255.255.255.0 masks IP addresses: 192.168.1.1...192.168.1.254.</p> <p>Please note: Do not use the first IP address 192.168.1.0 and last IP address 192.168.1.255.</p>
<b>Switch</b>	A switch, similar to a hub, is a connecting element to connect various network segments or network devices. Contrary to the hub, a switch is an intelligent device used to route packages only to the subnet or network device for which a package is destined.
<b>TCP</b>	<p>The TCP protocol is a TCP/IP protocol. TCP is responsible for transporting data between two communication partners (applications). TCP is a secured transmission protocol, i.e. a connection is established, monitored and disconnected to data transmission.</p> <p>TCP is a so-called connection-oriented protocol. The transmission control protocol TCP reassembles the data packages, sent by the Internet protocol IP via different network connections, in the right order at the Receiver.</p>
<b>TCP/IP</b>	Family of protocols used as the basis for the Internet. TCP/IP for the basis for any number of internet services such as <a href="#">HTTP</a> (Web), <a href="#">FTP</a> (file transfer) and <a href="#">SMTP</a> (mail).
<b>TLS</b>	<p><b>TLS (Transport Layer Security</b>, for [outdated]: SSL Secure Sockets Layer) a hybrid encryption protocol to transmit data over the Internet. TLS 1.0, 1.1 and 1.2 are standardized developments of SSL 3.0 (TLS 1.0 is now used for SSL 3.1). In other words, SSL is being further developed under the name TLS.</p> <p>The web server always uses TLS for e-mails if the e-mail provider supports TLS.</p>
<b>Transmission Control Protocol</b>	<i>See TCP.</i>
<b>Transport Layer Security</b>	<i>See TLS.</i>
<b>UDP</b>	UDP is a TCP/IP protocol to control data traffic between two communication partners (application). UDP, in contrast to TCP, is an unsecured protocol. UCP is a so-called connection-less protocol. Data packets are broadcast. The Receiver is responsible for receiving data. The sender does not receive notification if the data packages were received.

<b>Uniform Resource Locator</b>	<i>See URL.</i>
<b>Universal Plug and Play</b>	<i>See UPnP.</i>
<b>UPnP</b>	UPnP technology was designed for home and office networks. Devices supporting UPnP automatically configure their network settings as soon as connected to a network. In addition, they automatically provide, depending on class, own services or use services of other devices on the network.
<b>URL</b>	A URL refers to an information source, e.g. <a href="http://www.siemens.com">http://www.siemens.com</a> . The URL is a uniform web address that is used to determine the network protocol used (e.g. http) or the location of the resource on the network.
<b>User Datagram Protocol</b>	<i>See UDP.</i>
<b>WAN</b>	The wide area network WAN has a spatial dimension of ca. 50 km. A WAN can comprise a number of several LANs. If an ISP operates a WAN, private LAN users receive access to the Internet.
<b>Wide Area Network</b>	<i>see WAN.</i>
<b>Wireless LAN</b>	<i>see WLAN.</i>
<b>WLAN</b>	Wireless LANs allow network devices to communicate via radio. The WALN can be added as an extension to a wired LAN, or it can be the basis of a new network.

# Index

---

<b>1</b>		
1 bit data points .....	129	
1 byte data points .....	131	
<b>2</b>		
2 bit data points .....	130	
2 byte data points .....	132	
<b>4</b>		
4 byte data points .....	133	
<b>A</b>		
Abbreviations .....	11	
ACS trend .....	121	
Activate Energy indicator function		
Data point monitoring .....	81	
Address translation (NAT).....	98	
Administer user accounts .....	15	
Alternative network configuration .....	148	
<b>B</b>		
Blind control .....	122	
Bus load .....	110	
<b>C</b>		
Commissioning		
Additional settings .....	35	
Create device web pages.....	17	
Final steps .....	36	
Functional check .....	33	
Local operator station.....	31	
Log onto web server.....	14	
Message receiver.....	25	
Network components .....	31	
Prerequisites .....	12	
Router settings .....	32	
Turn on web server .....	13	
Communication		
E-mail .....	101	
Internet protocol .....	144	
Private networks.....	144	
Remote operation.....	93	
Consumption data.....	28	
COV .....	140	
Create own plant web pages .....	57	
<b>D</b>		
Data point address.....	108	
Data point types .....	127	
Data points.....	124	
Date/time .....	20	
Deactivate Energy indicator function		
Confirmation message.....	80	
Data point monitoring.....	79	
Green limits to default values .....	80	
Monitoring off .....	80	
Summary checkbox .....	80	
Device Description .....	70	
Device faults .....	44	
Device information.....	42	
Ethernet .....	43	
KNX.....	42	
Device web pages .....	71	
Diagnostics Web server .....	42	
Dialog box Energy indicator		
Comfort cooling setpoint.....	84	
Comfort heating setpoint.....	84	
Data point value .....	83	
Enumeration data points .....	85	
General .....	83	
Numeric data points .....	84	
Operating mode .....	85	
Setting range.....	83	
Variable unit data points.....	86	
Display and operating elements .....	7	
DynDNS .....	100	
<b>E</b>		
Edit data point address.....	119	
E-mail		
Receiver .....	115	
Test receiver.....	114	
Transmission options .....	114	
Transmit interval .....	115	
Trend data.....	113	
E-mail Energy indicator		
Configure E-mail receiver .....	89	
Contents.....	91	
Energy indicator of plant .....	89	
Mailbox.....	90	
E-mail Trend receiver .....	113	
Energy indicator		
Green leaf .....	68	
Grey leaf .....	68	
Orange leaf .....	68	
Summary display .....	77	
Temporary status .....	78	
Visibility .....	76	
Energy values.....	122	
ETS.....	124, 135	
Example of a plant web page.....	52	

<b>F</b>			
Fault codes .....	142	Lighting control .....	122
Faults current		Local area network .....	97
Local .....	44	<b>M</b>	
System.....	45	Message receiver	
Firewall.....	98	Holidays/special days .....	26
Firmware update.....	37	Monday - Sunday, special day .....	26
Function Energy indicator		Receiver type .....	25
Commissioning.....	78	<b>N</b>	
Estimated processing time .....	79	Notations .....	11
Monitored data points and green limit(s).....	68	<b>O</b>	
Number of monitored data points .....	75	Offline trend. ....	121
Quantity Energy indicator data points .....	69	Operate the plant.....	40
User groups service and end user .....	88	Operate web server .....	40
<b>G</b>		Operate&monitor .....	51
Group addresses .....	135	Operation	
<b>H</b>		Faults .....	44
Heartbeat. ....	140	File transfer .....	46
HIT .....	55	Overview .....	38
Holidays/special days .....	26	Operation KNX devices .....	40
<b>I</b>		<b>P</b>	
Import		Plant diagrams.....	55
Trend definition.....	118	Plant state Energy indicator	
Install RNDIS driver		Green leaf .....	77
Automatically .....	145	Orange leaf .....	77
Manually .....	146	Summary display .....	77
Internet connection .....	97	Plant web pages .....	51
Invalid characters.....	142	Port forwarding (PAT) .....	99
<b>K</b>		Primary navigation.....	8
KNX		Private networks .....	144
Data exchange .....	135	<b>R</b>	
Data point display in OZW.....	139	Remote operation via the Internet.....	97
Data point names .....	126	RNDIS driver .....	145
Data point types .....	127	<b>S</b>	
Data points .....	124	Scene control.....	122
Default subtypes.....	141	Secondary navigation.....	8
Group addresses.....	135	Send messages.....	26
Interfaces.....	123	Settings	
Page display in OZW.....	139	Consumption data .....	28
Pages .....	125	E-Mail	
Plant diagram .....	122, 140	Mailserver address .....	24
Project data .....	137	Mailserver port number .....	24
Set values.....	139	Sender e-mail address .....	24
KNX devices .....	70	Ethernet	
KNX S-Mode .....	122	IP address, IP subnet address .....	23
<b>L</b>		Konnex	
Language .....	21	Bereich, Line, Device address.....	22
Levels Energy indicator function		Clock time mode Konnex .....	22
Data points .....	74	Remote setting clock slave Konnex .....	22
Partial plants.....	73	Web server.....	21
Plant .....	72		

S-mode .....	122	Export.....	118
Standard applications .....	55	Import.....	118
Start Function Energy indicator .....	78	Information .....	107
Summary checkbox Energy indicator .....	80	RAM .....	112
Summary display Energy indicator .....	77	Reset.....	110
Supply state .....	37	Transmission options .....	114
Symbols .....	10	Transmit interval .....	114
Synco range.....	70	Trend functions.....	106
System definitions update .....	37		
System report		<b>U</b>	
Message cycle.....	27	UPnP localization .....	25
Next report.....	27	User levels.....	9
Priority .....	27		
Signal time.....	27	<b>V</b>	
<b>T</b>		Valid characters .....	142
Text entry .....	142	Visibility Energy indicator .....	76
Time of day/date .....	20	Visualize .....	51
Time synchronization, Time zone.....	21		
Transmit project data .....	137	<b>W</b>	
Tree leaf as Energyindicator.....	68	Web operation, user interface .....	8
Trend		Web page	
ACS .....	121	Energy indicator function .....	69
Bus load ACS .....	121	Energy indicator update.....	78
Channel .....	114	Web server	
Compatibility.....	121	Fault codes .....	142
Copy .....	120	Language .....	21
Data points .....	111	Web server diagnostics .....	42
Define .....	107	Web server settings.....	20
Download file.....	117	Windows Commander .....	143
E-mail .....	113		

Siemens Switzerland Ltd  
Infrastructure & Cities Sector  
Building Technologies Division  
Gubelstrasse 22  
6301 Zug  
Switzerland  
Tel. +41 41-724 24 24  
[www.siemens.com/sbt](http://www.siemens.com/sbt)

© 2009-2014 Siemens Switzerland Ltd  
Subject to change